



ສາທາລະນະລັດ ປະຊາທິປະໄຕ ປະຊາຊົນລາວ
LAO PEOPLE'S DEMOCRATIC REPUBLIC

ກະຊວງ ອຸດສາຫະກຳ ແລະ ການຄ້າ
ກົມຊັບສິນທາງປັນຍາ

MINISTRY OF INDUSTRY AND COMMERCE
DEPARTMENT OF INTELLECTUAL PROPERTY

ຈົດໝາຍເຫດທາງລັດຖະການ
ກ່ຽວກັບ ຊັບສິນທາງປັນຍາ
ຢູ່ ສປປ ລາວ

OFFICIAL GAZETTE ON INTELLECTUAL PROPERTY
IN LAO PDR

ສະບັບທີ (Vol.) 171

ພາກທີ I

(Part I)

ສິດທິບັດ ແລະ ອະນຸສິດທິບັດ (Patent and Petty Patent)

1. ຄໍາຮ້ອງ

(Applications)

ຄໍາອະທິບາຍກ່ຽວກັບລະຫັດຫຍໍ້

(Introduction of Codes)

- (21) ເລກທີ ຄໍາຮ້ອງ (Filing Number)
- (22) ວັນທີ ຍືນຄໍາຮ້ອງ (Filing Date)
- (30) ວັນທີ ບຸລິມະສິດ (Priority Date)
- (43) ວັນທີເຜີຍແຜ່ (Publication Date)
- (51) ໝວດ (International Patent Classification)
- (54) ຊື່ຂອງການປະດິດ (Title)
- (57) ບົດຄັດຫຍໍ້ (Abstract)
- (71) ຊື່ ແລະ ທີ່ຢູ່ ເຈົ້າຂອງສິດທິບັດ ແລະ ອະນຸສິດທິບັດ (Owner Name and Address)
- (72) ຊື່ຜູ້ປະດິດ (Inventor Name)
- (74) ຊື່ຕົວແທນ (Representative Name)
- (55) ຮູບພາບ (Pictures)

ພາກທີ I (Part I)

ສິດທິບັດ ແລະ ອະນຸສິດທິບັດ (Patent and Petty Patent)

2. ຜົນການອອກສິດທິບັດ ແລະ ອະນຸສິດທິບັດ (Grant of Patents and Petty Patents)

ຄຳອະທິບາຍກ່ຽວກັບລະຫັດຫຍໍ້ (Introduction of Codes)

- (11) ເລກທີ (Grant Number)
- (21) ເລກທີ ຄຳຮ້ອງ (Filing Number)
- (22) ວັນທີຍື່ນຄຳຮ້ອງ (Filing Date)
- (30) ວັນທີ ບຸລິມະສິດ (Priority Date)
- (43) ວັນທີເຜີຍແຜ່ (Publication Date)
- (51) ໝວດ (International Patent Classification)
- (54) ຫົວຂໍ້ການປະດິດ (Title)
- (57) ບົດຄັດຫຍໍ້ (Abstract)
- (71) ຊື່ ແລະ ທີ່ຢູ່ ເຈົ້າຂອງສິດທິບັດ ແລະ ອະນຸສິດທິບັດ (Owner Name and Address)
- (72) ຊື່ຜູ້ປະດິດ (Inventor Name)
- (74) ຊື່ຕົວແທນ (Representative Name)
- (55) ຮູບພາບ (Pictures)

- (11) No. 96
- (21) PA 96
- (22) 04/02/2009
- (30)
- (43)
- (51) Int.C1.8A 01G 1/00, A 01G 13/00, A 01G 7/00, A 01G 27/00, A 01G 25/00
- (54) PLANT CULTIVATION SYSTEM
- (57) .
- (71) MEBIOL INC.
1-25-8, Nakahara, Hiratsuka-shi, Kanagawa-ken, 254-0075 JAPAN, Japan.
- (72) Akihiro OKAMOTO; Manabu FUJII; Hiroshi YOSHIOKA and Yuichi MORI.
- (74) Lao Trademark Agency.
- (55)

1/2

[Fig. 1]

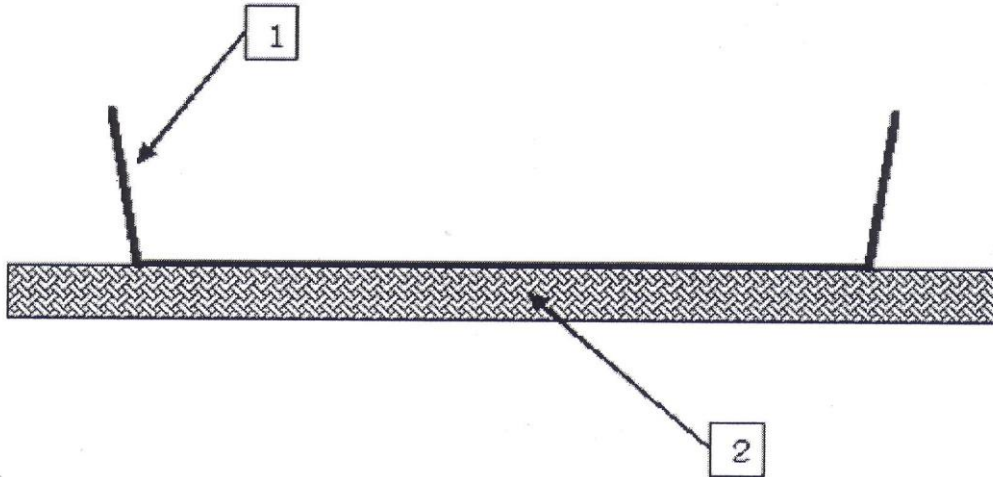

[Fig. 2]

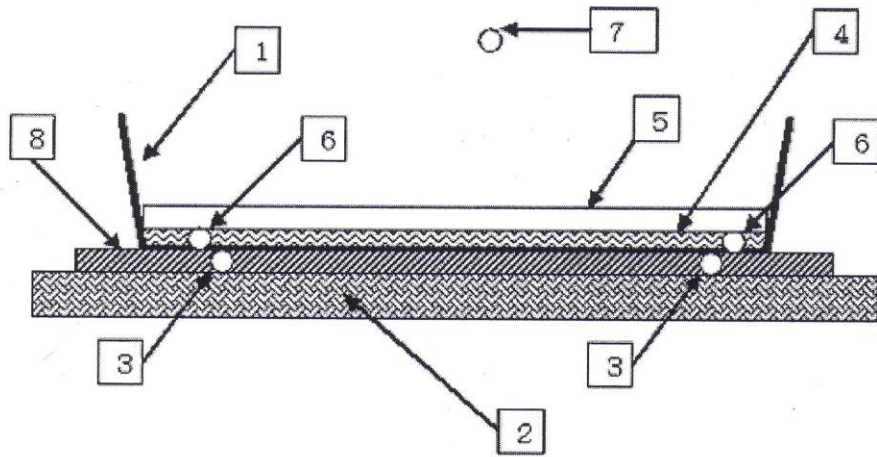

2/2

[Fig. 3]

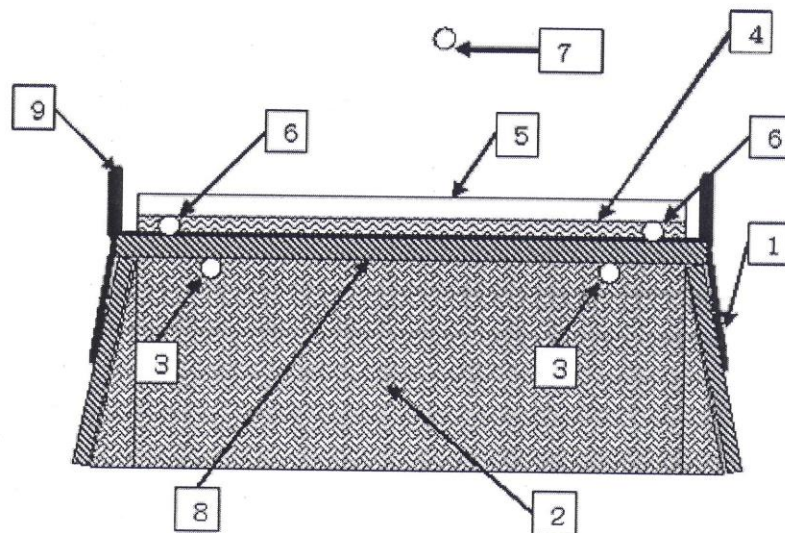

- (11) No. 612
- (21) PA 612
- (22) 03/10/2018
- (30) 201610204830.5 05/04/2016 CN
- (43)
- (51) Int.Cl.H 04L 12/24(2006.01)
- (54) Data Processing System for Providing Business Continuity Protection
- (57) The present invention relates to a data processing system providing service continuity protection, comprising: a service center, comprising a first data processing unit, a first front-end communications unit, and at least one first rear-end communications unit; a disaster recovery center, comprising a second data processing unit, a second front-end communications unit, and at least one second rear-end communications unit; when the service center is operating normally, the first front-end communications unit and second front-end communications unit are coupled in communication with the first rear-end communications unit; when the disaster recovery center operates instead of the service center, the first front-end communications unit and second front-end communications unit are coupled in communication with the second rear-end communications unit; the invention switches reliably between the service center and the disaster recovery center, providing improved service continuity protection. Furthermore, the data processing system conserves network overhead, reduces development and operation/maintenance costs, and enables rapid switching between operating states..
- (71) CHINA UNIONPAY CO., LTD.
CUP Tower, 36 Hanxiao Rd., Pudong New Area Shanghai
200135, People's Republic of China, China.
- (72) CHEN, Lin; YANG, Sen; ZHANG, Junhao; ZHANG, Xiaoming and XU, Liwei.
- (74) CONCETTI-LAO CO., LTD.
- (55)

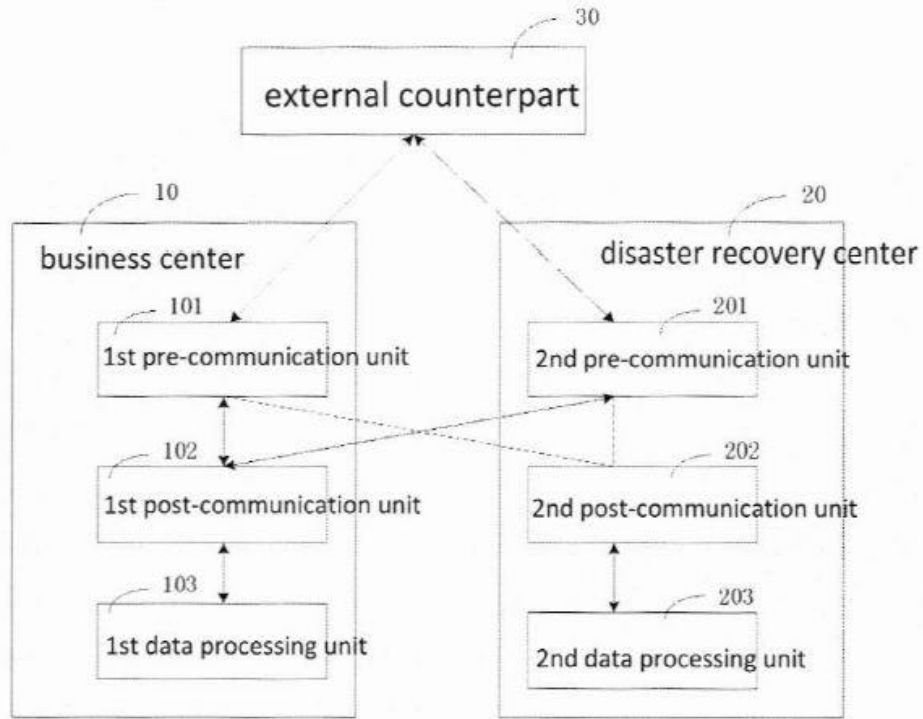

Fig. 1

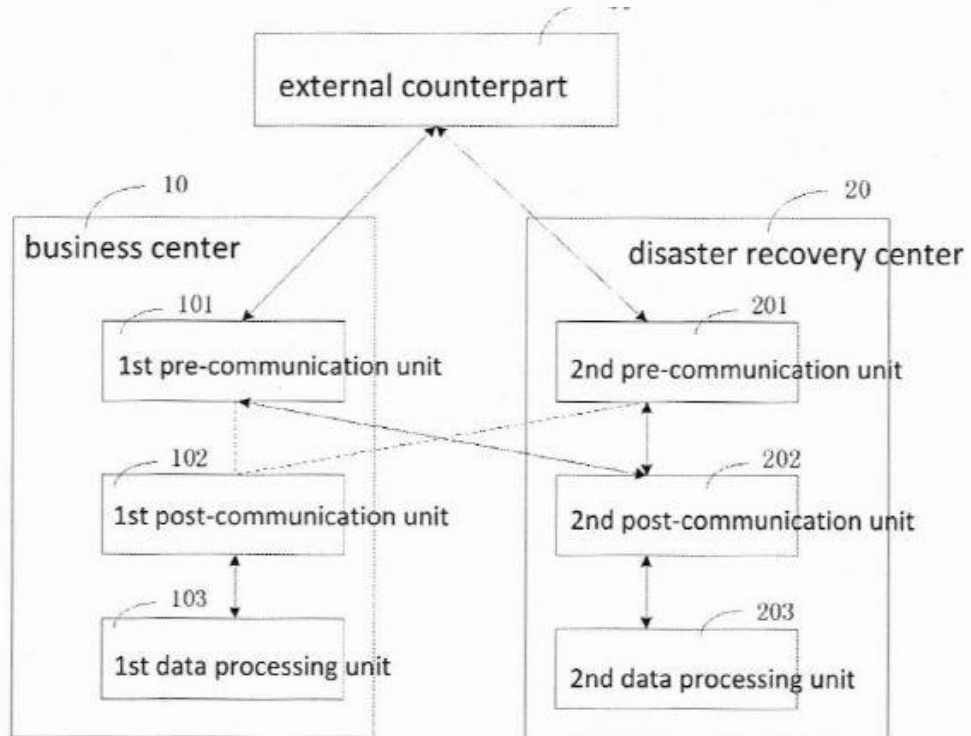
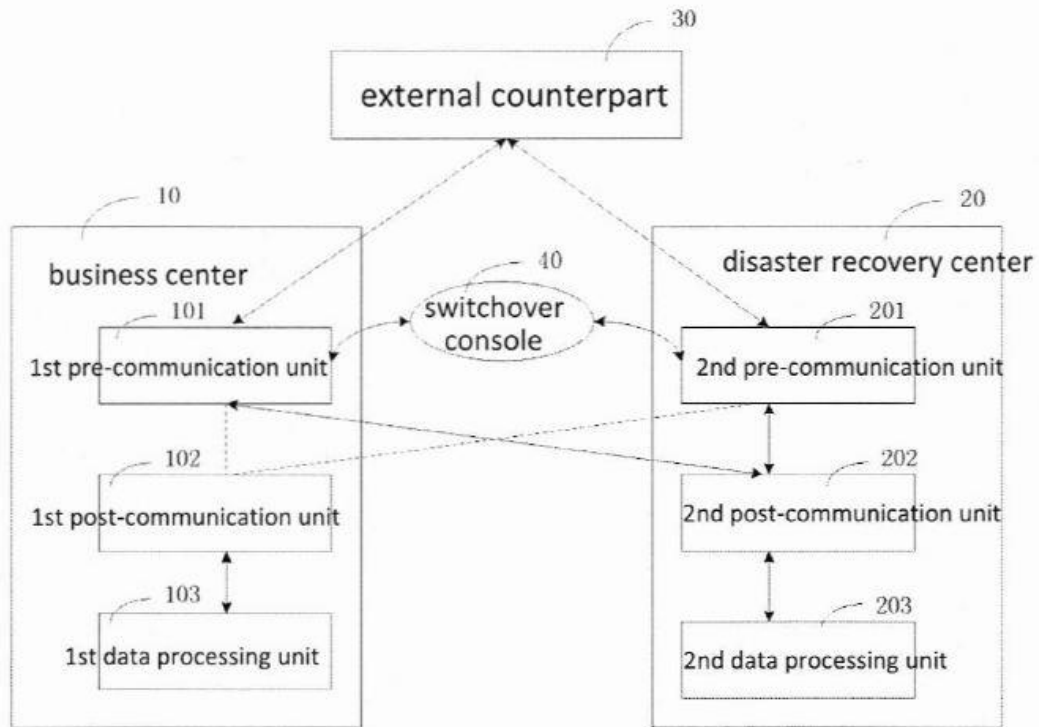

Fig. 2



- (11) No. 631
- (21) PA 631
- (22) 02/01/2019
- (30)
- (43)
- (51) Int.Cl.C 07J 17/00(2006.01)
// (C 07J 17:00)
- (54) METHOD FOR SEPARATING AND PURIFYING MOGROSIDE V BY SUBCRITICAL WATER DESORPTION TECHNOLOGY TECHNOLOGY
- (57) --.
- (71) GUILIN LAYN NATURAL INGREDIENTS CORP.
No.19 South Renmin Road, Lingui Guilin, Guangxi 541199, China.
- (72) JIANG, Minglian; YANG, Wenguo; SONG, Yunfei and LI, Yuanyuan.
- (74) .
- (55)

- (11) No. 649
- (21) PA 649
- (22) 20/03/2019
- (30)
- (43)
- (51) Int.Cl.2018.01C 05D 3/04(2006.01), C 05D 9/02(2006.01), C 21C 1/02(2006.01), C 21C 5/28(2006.01)// (C 21C 1:02, 5:28)
- (54) --
- (57) --.
- (71) NIPPON STEEL & SUMITOMO METAL CORPORATION
6-1, Marunouchi 2-chome, Chiyoda-ku, Tokyo 1008071, Japan.
- (72) ITO, Kimio.
- (74) .
- (55)

- (11) No. 680
- (21) PA 680
- (22) 27/09/2019
- (30) 2017-063937 28/03/2017 JP
- (43)
- (51) Int.Cl.H 02J 13/00(2006.01), G 06F 3/0481(2013.01), G 06F 3/14(2006.01), G 06T 11/20(2006.01)
- (54) MONITORING SYSTEM, IMAGE INFORMATION PROVIDING DEVICE, CLIENT CONTROL DEVICE, IMAGE INFORMATION PROVIDING PROGRAM, AND CLIENT CONTROL PROGRAM
- (57) A monitoring system that can easily cope with change of a monitoring range is provided. The monitoring system includes a monitoring control device, an image 5 information providing device, and a client control device. The monitoring control device monitors infrastructure facilities and transmits statuses of the infrastructure facilities acquired on the basis of information input from a sensor to the image information providing device. The image information providing device generates original image information on the basis of the infrastructure facility statuses received 10 from the monitoring control device. The client control device is connected to a display device and an operation device, receives information for designating a partial area of an entire image capable of being generated from the original image information from the operation device, transmits the received information to the image information providing 15 device, and displays an image based on information received from the image information providing device on the display device..
- (71) TOSHIBA ENERGY SYSTEMS & SOLUTIONS CORPORATION 7 2-34, Horikawa-cho, Saiwai-ku, Kawasaki-shi, Kanagawa 212-0013 Japan
TOKYO ELECTRIC POWER COMPANY HOLDINGS, INCORPORATED 1-3, Uchisaiwai-cho 1-chome, Chiyoda-ku, Tokyo 100-8560 Japan
- (72) Hiroaki FUJIURA; Masaru KAWAKAMI ; Hiroyuki YABE ; Yuji FUJIMOTO ; Shinobu KAWASHIMA ; Koichi TAKEUCHI ; Junya YAMAMOTO ; Tomohiro KUBO ; Masanori ENDO ; Kenji KITAMI ; Takaaki HOSAKA ; Jun INOUE and Takashi EGUCHI.
- (74) Tilleke & Gibbins International Ltd.
- (55)

[図1]

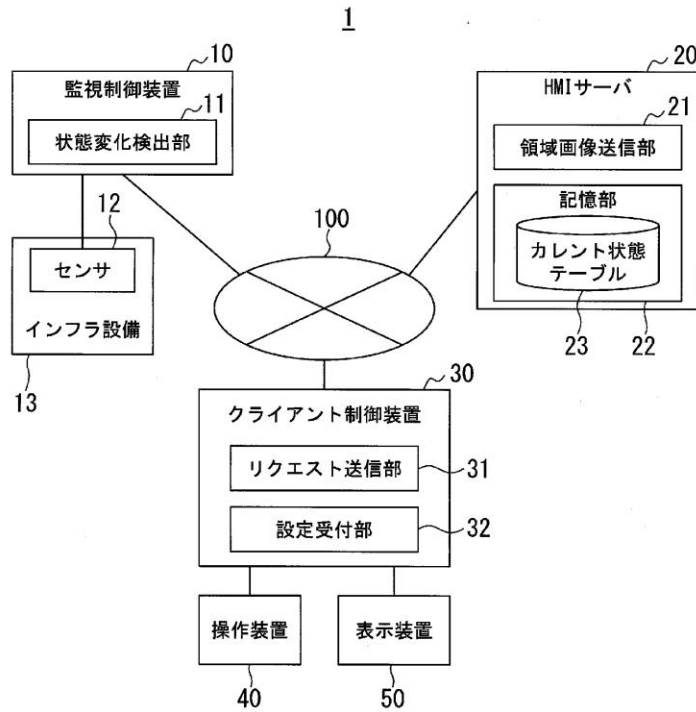

[図2]

23

| 状態 番号 | 状態情報 | | | | 応答情報 | |
|----------|------|------|------|------|------|-------|
| | 種別 | 発生領域 | 表示領域 | 表示形態 | 確認済み | 表示ロック |
| 1 | 停電 | 200x | 200x | 系統図 | なし | なし |
| 2 | ... | ... | ... | ... | ... | ... |
| 3 | ... | ... | ... | ... | ... | ... |

[図3]

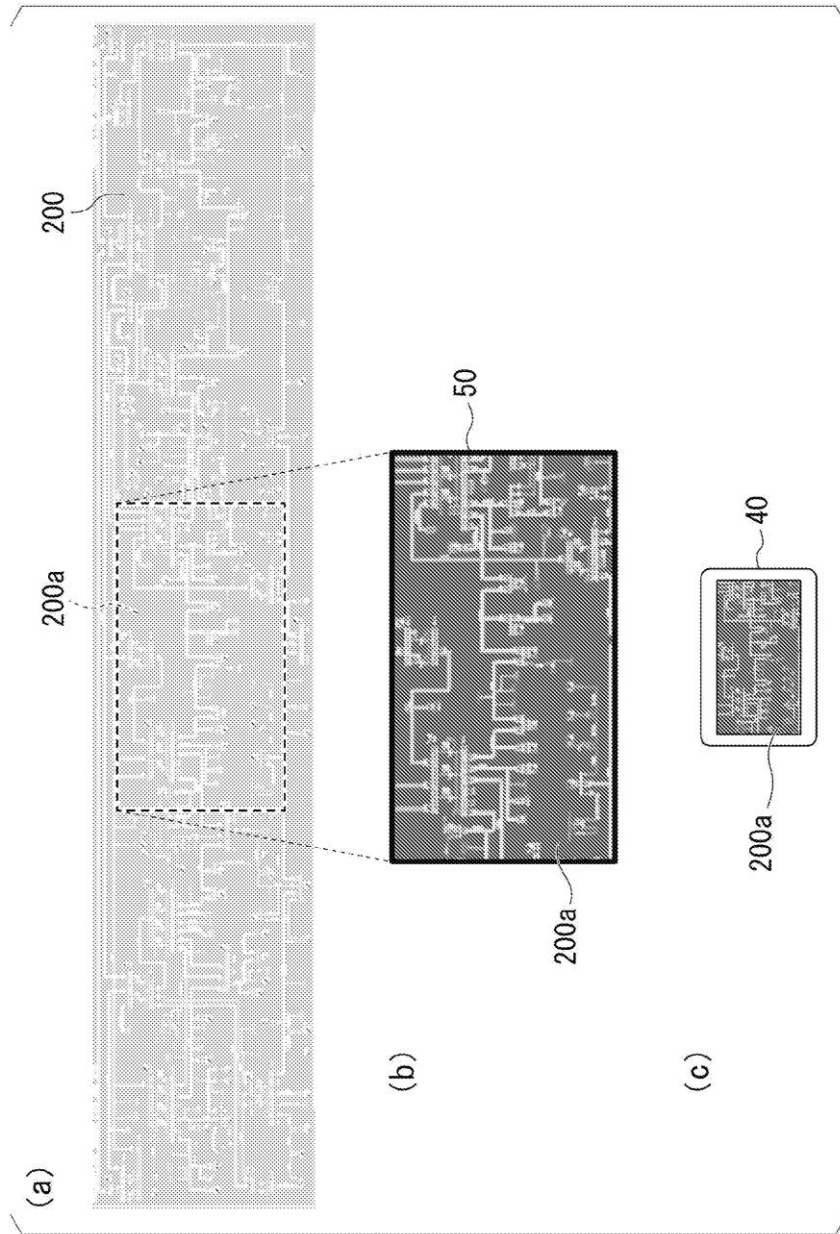

[図4]

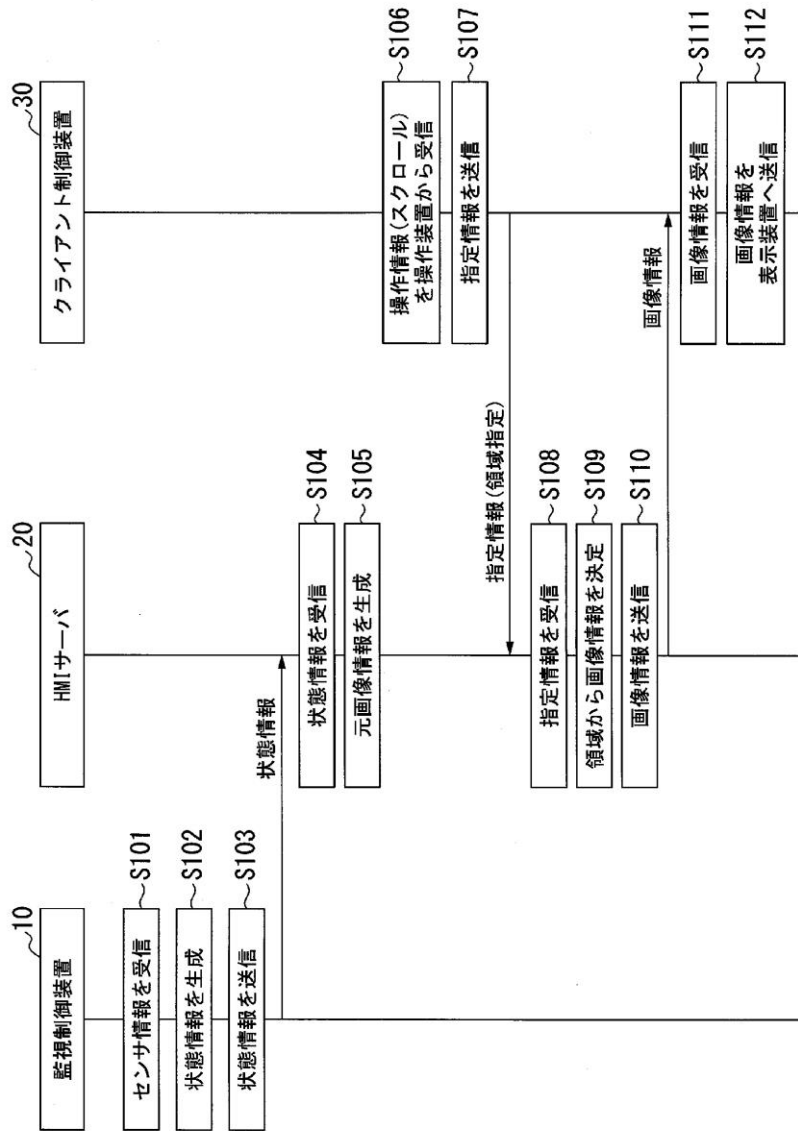

[図5]

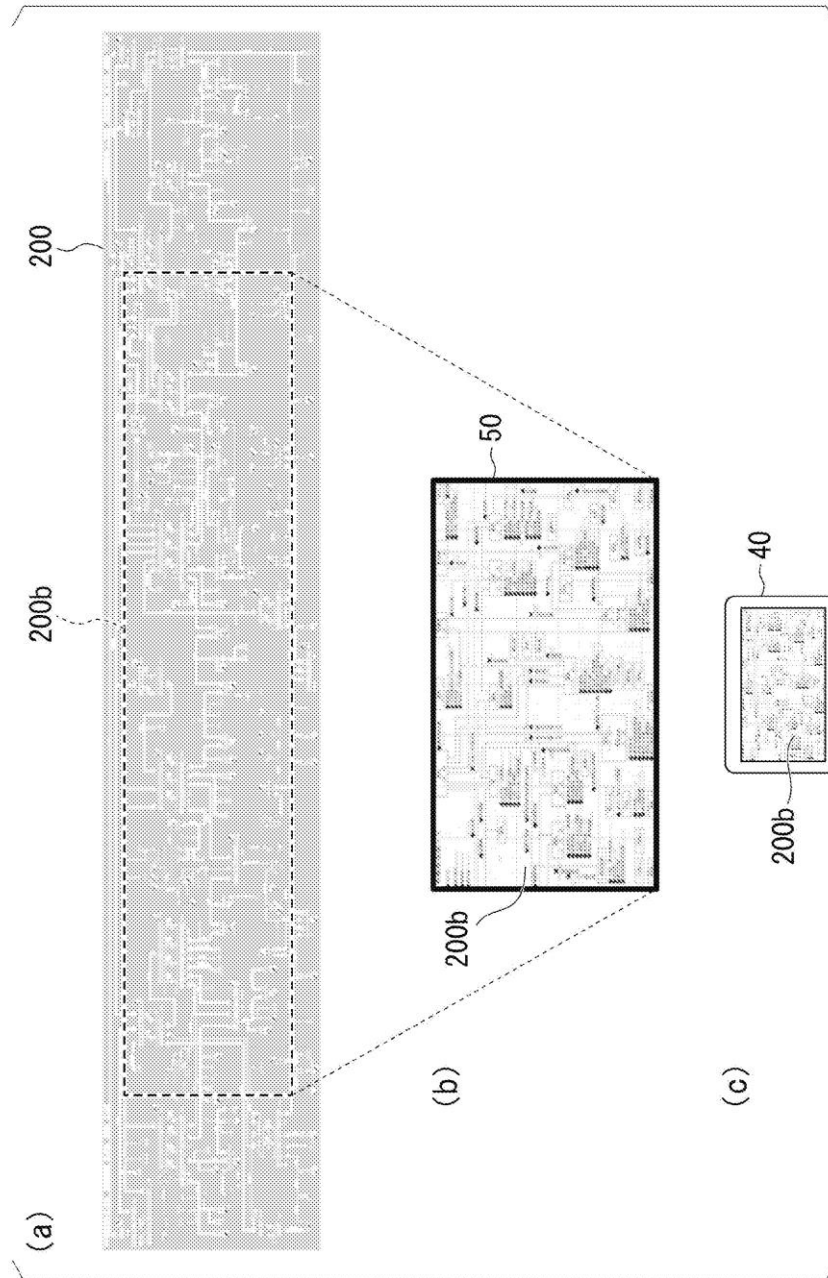

[図6]

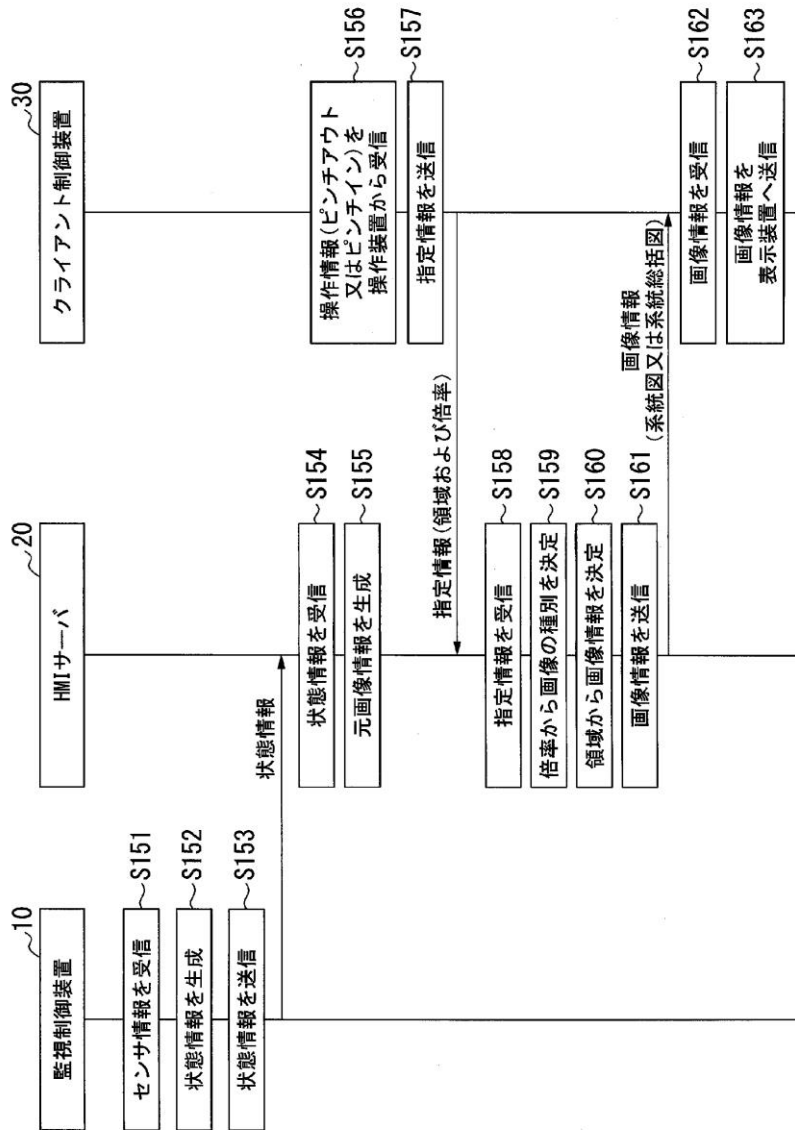

[図6]

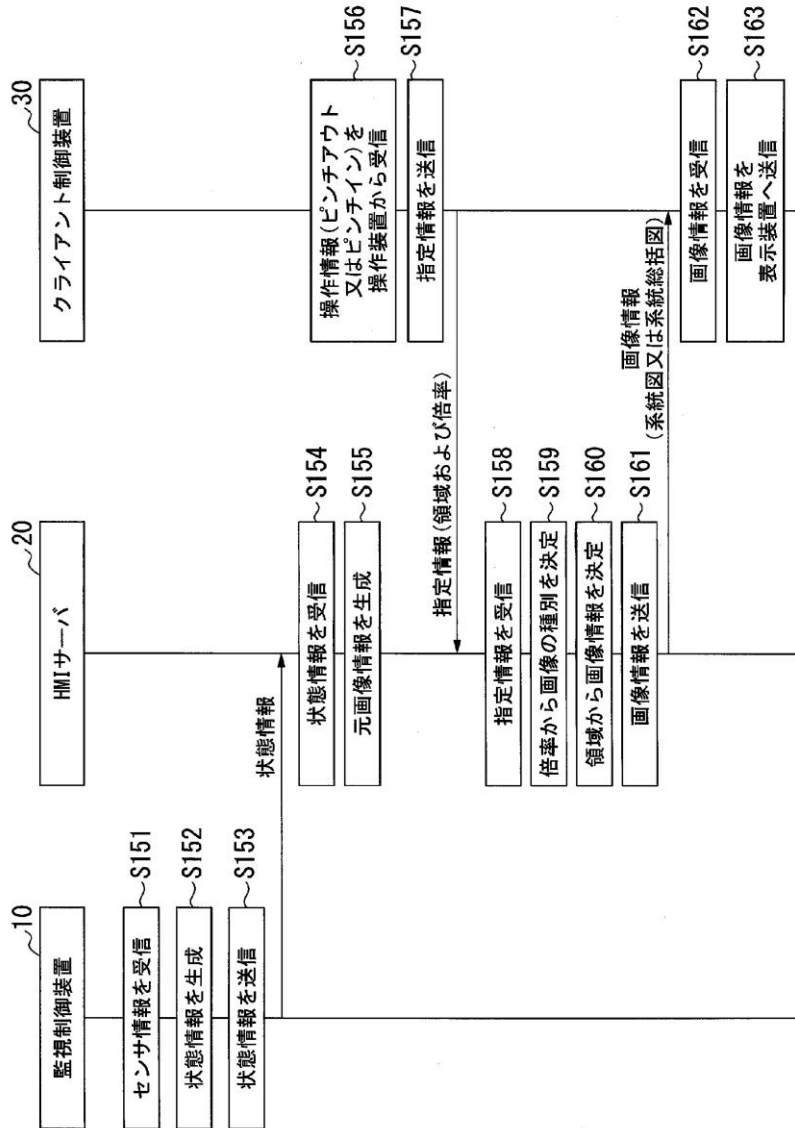

[図7]

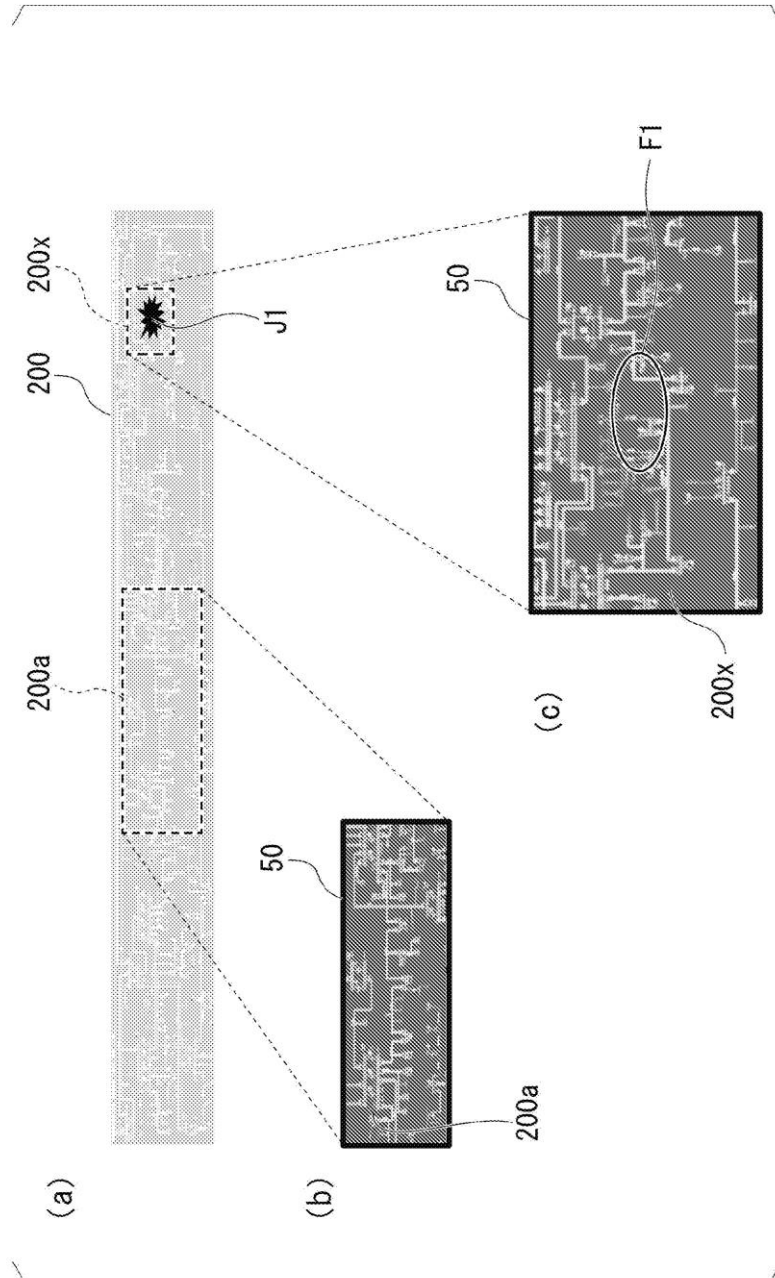

WO 2018/181598

PCT/JP2018/013012

[図8]

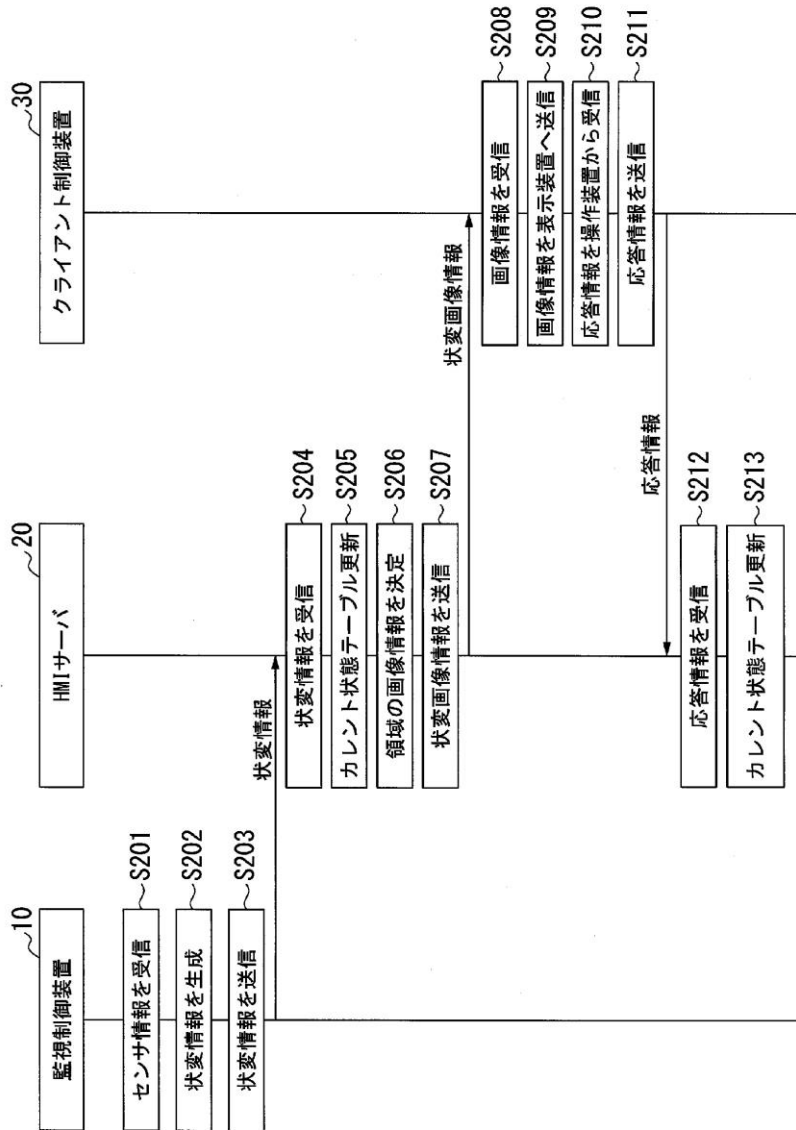

[図9]

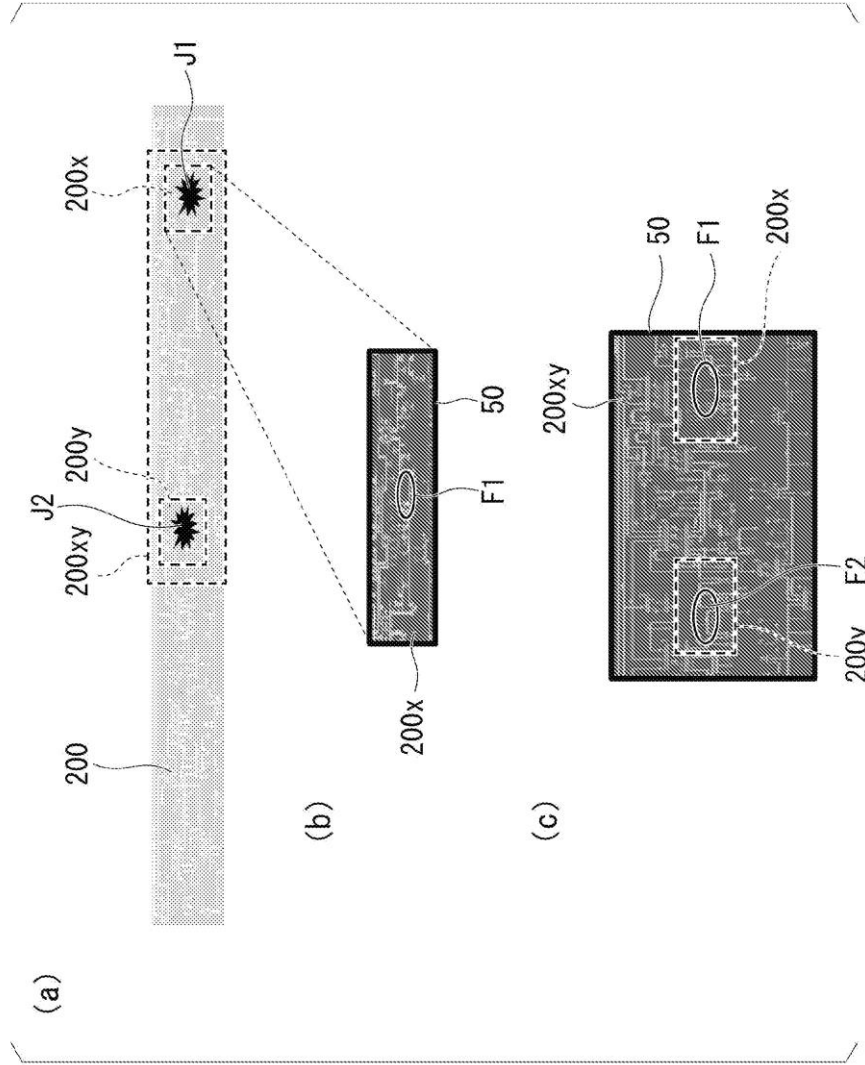

[図11]

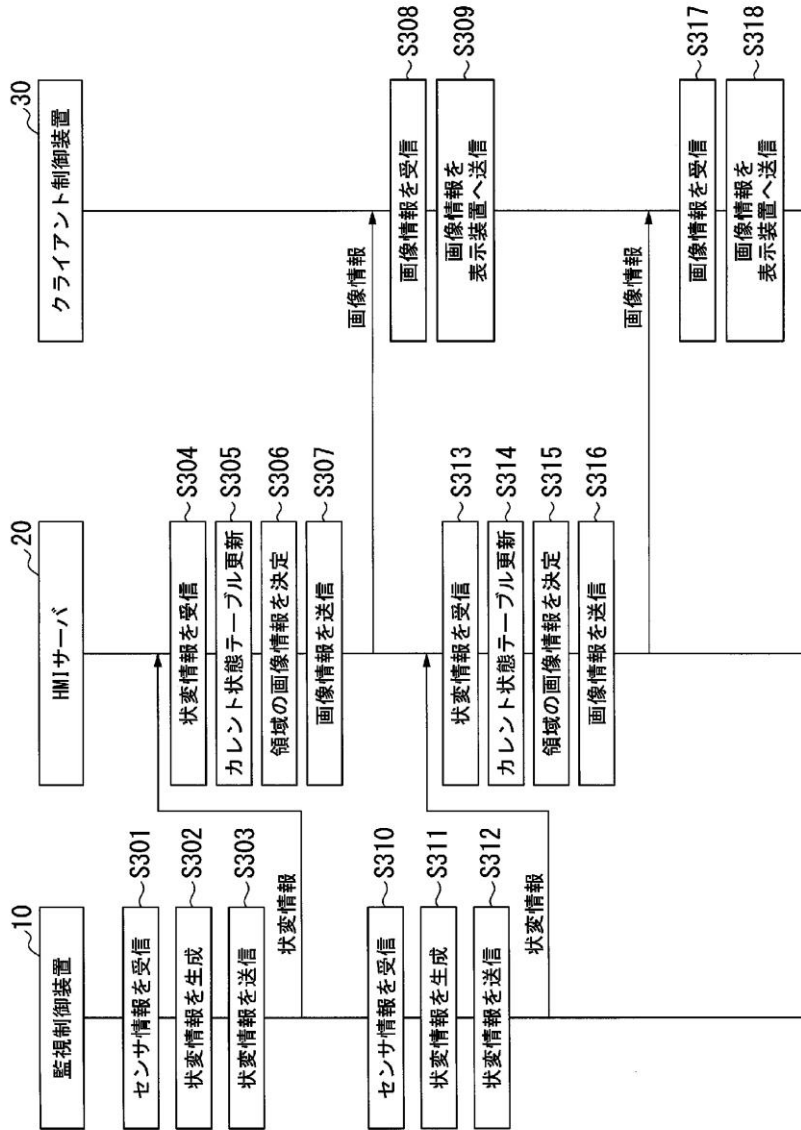

[図12]

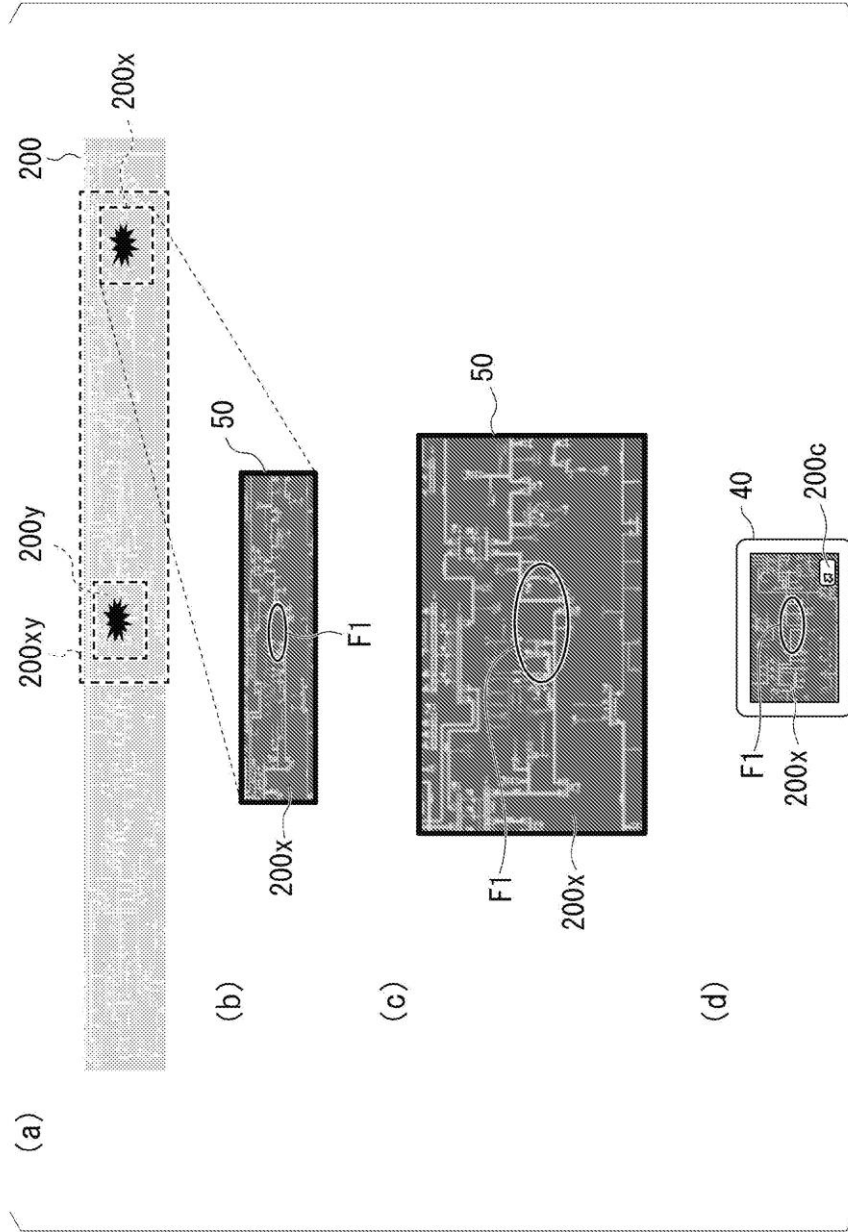

【図13】

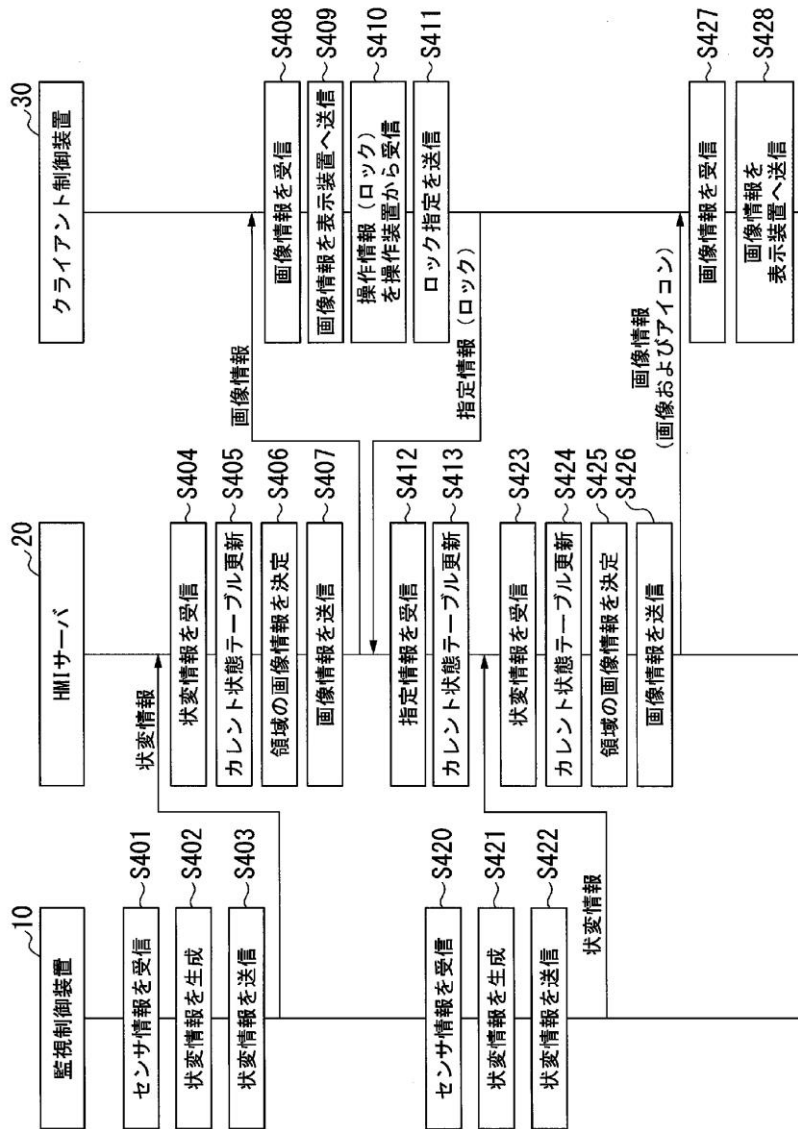

[図14]

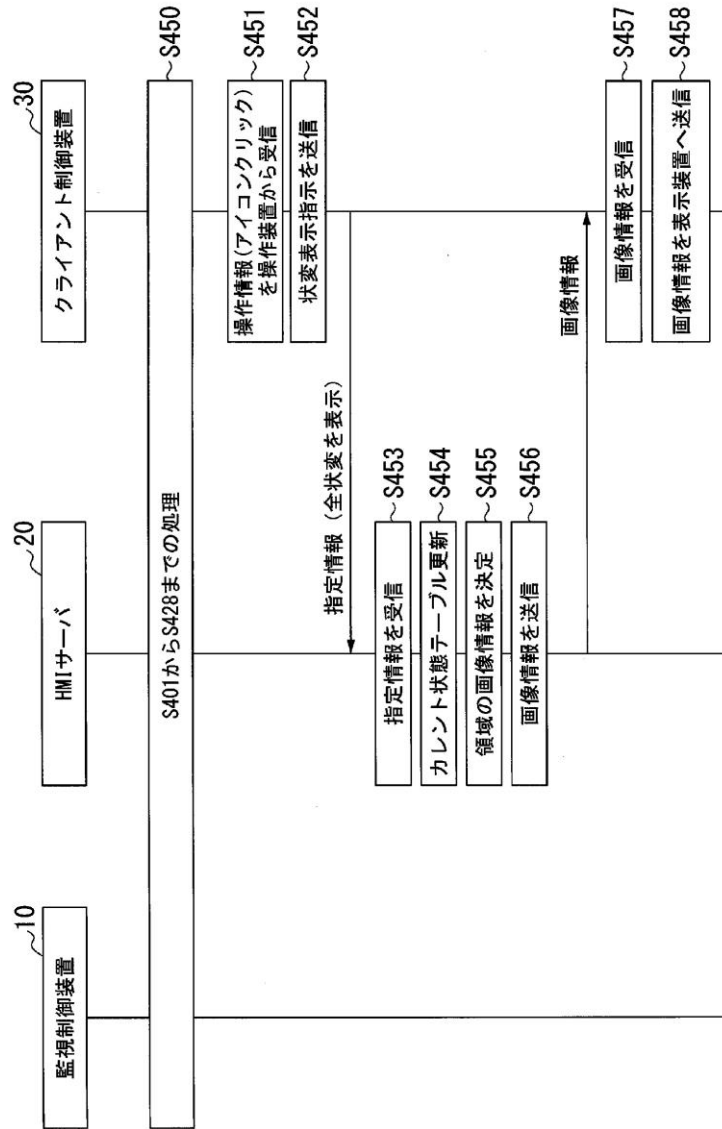

- (11) No. 691
- (21) PA 691
- (22) 26/11/2019
- (30) PCT/SG2017/050271 26/05/2017 SG
- (43)
- (51) Int.Cl.
- (54) SYSTEMS AND METHODS FOR MANAGING SHUTTLE SERVICES AND DERIVING OF SHUTTLE SERVICE ROUTES AND SERVICES
- (57) .
- (71) GRABTAXI HOLDINGS PTE. LTD
6 Shenton Way, #38-01 OUE Downtown, Singapore 068809 , Singapore.
- (72) .
- (74) Tilleke & Gibbins International Ltd.
- (55)

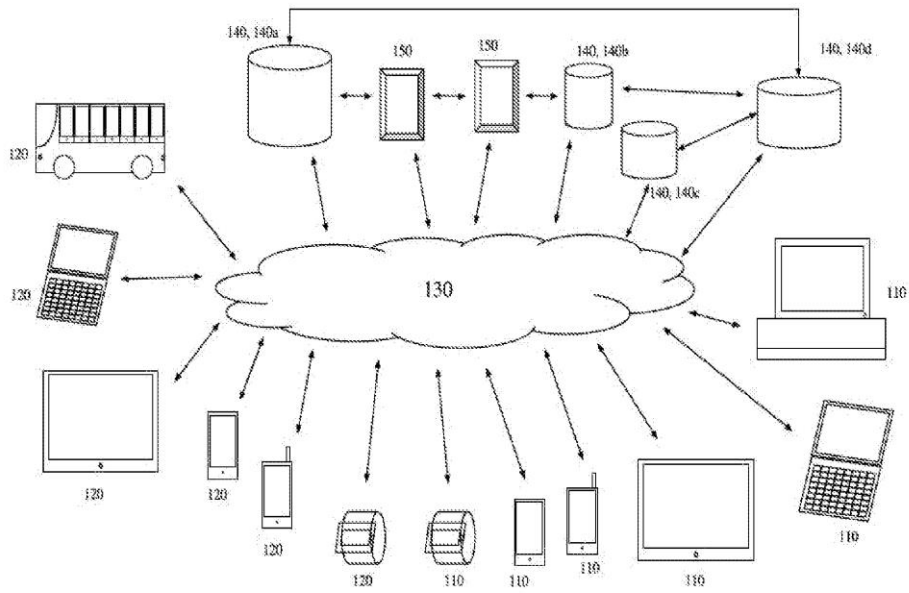

Figure 1

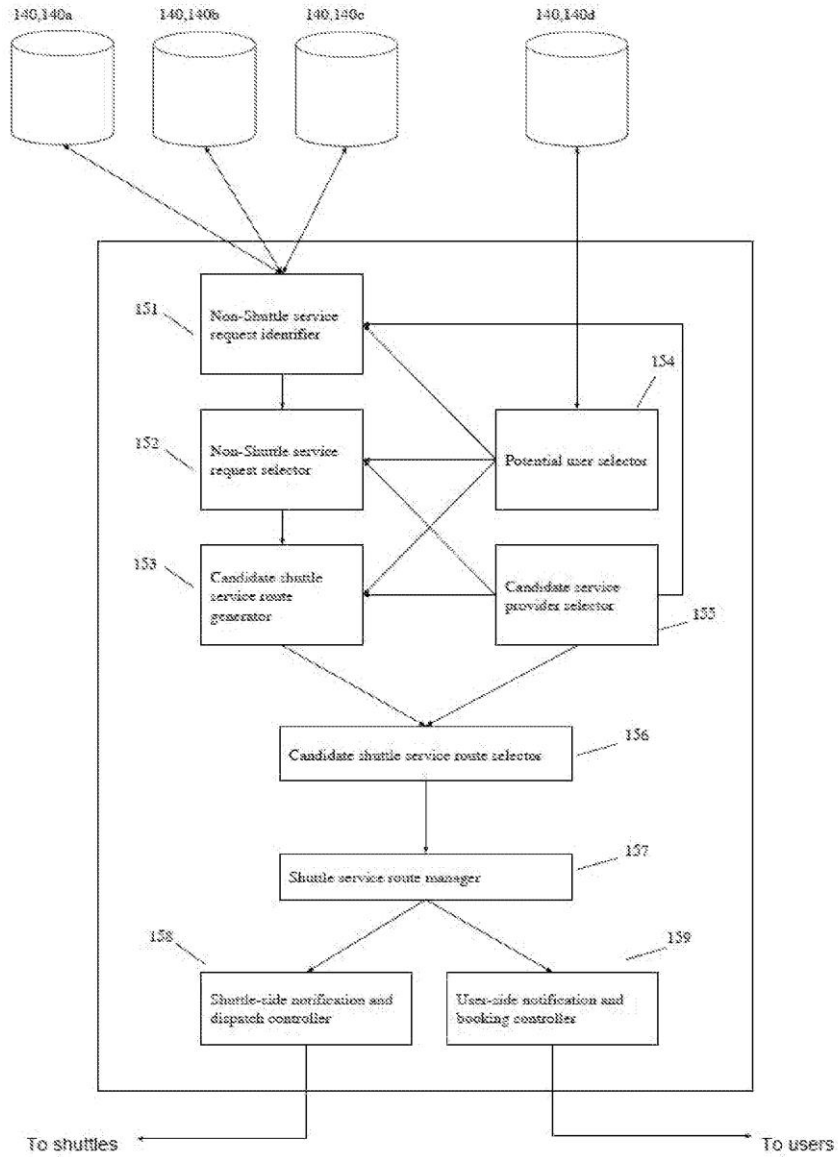

Figure 2

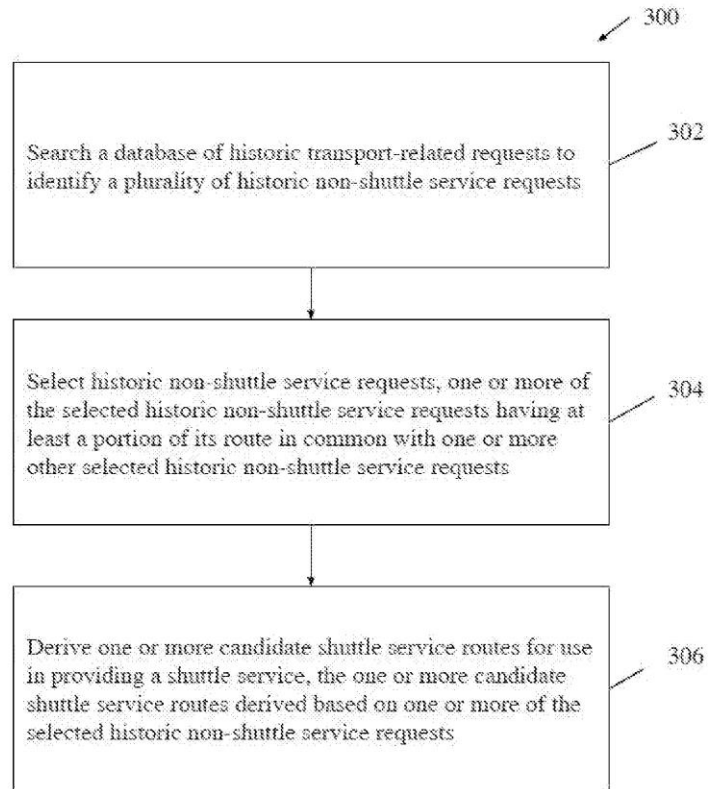

Figure 3

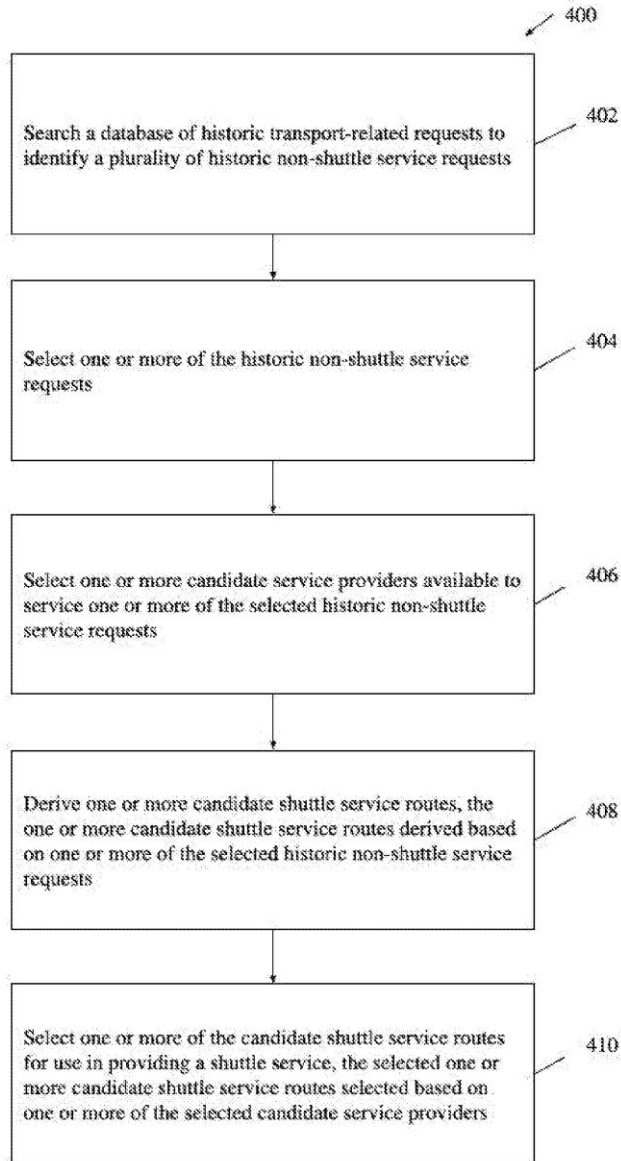

Figure 4

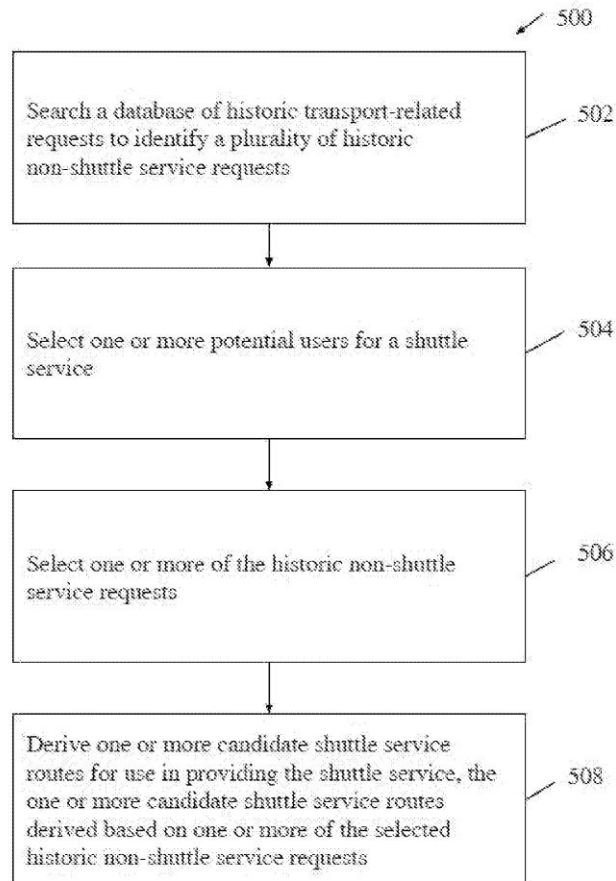

Figure 5

(11) No. 696

(21) PA 696

(22) 17/12/2019

(30) 2017-129502 30/06/2017 JP

(43)

(51) Int.Cl.C 22C 38/00(2006.01), C 22C 38/60(2006.01), C 23C 26/00(2006.01), C 23C 28/00(2006.01)

(54) STRUCTURALSTEEL MATERIAL AND STRUCTURE

(57) he purpose of the present invention is to provide a structural steel material: with which it is possible to reduce painting frequency even when used in an atmospheric corrosive environment, especially when used in a severe corrosive environment in which there is a large amount of airborne salt, such as at sea, in the vicinity of a coast, etc.; and that exhibits good primary rust resistance, superior paint corrosion resistance, and superior lamellar tear resistance when being employed in a large complex structure such as a bridge. The structural steel material of the present invention has a predetermined composition and has a degree of Sn segregation that is set to 20 or less..

(71) JEE STEEL CORPORATION

2-3, Uchisawai-cho 2-chome, Chiyoda-ku, Tokyo 1000011, JAPAN, Japan.

(72) MIURA, Shinichi; SAMUSAWA Itaru ; MURASE Masatsugu ; SHIOTANI Kazuhiko and HASE Kazukuni.

(74) ACTIP IP LIMITED [ACTIP].

(55)

ພາກທີ I

(Part I)

ສິດທິບັດ ແລະ ອະນຸສິດທິບັດ
(Patent and Petty Patent)

3. ການປ່ຽນແປງ

(Changes)

ພາກທີ I

(Part I)

**ສິດທິບັດ ແລະ ອະນຸສິດທິບັດ
(Patent and Petty Patent)**

4. ການດັດແກ້

(Amendments)

ພາກທີ II
(Part II)
ແບບອຸດສາຫະກຳ
(Industrial Design)

1. ຄຳຮ້ອງ
(Applications)

ຄຳອະທິບາຍກ່ຽວກັບລະຫັດຫຍໍ້
(Introduction of Codes)

- (21) ເລກທີ ຄຳຮ້ອງ (Filing Number)
- (22) ວັນທີ ຄຳຮ້ອງ (Filing Date)
- (30) ວັນທີ ບຸລິມາສິດ (Priority Date)
- (51) ໝວດ (Locarno Classification)
- (54) ຊື່ຂອງແບບອຸດສາຫະກຳ (Title)
- (71) ຊື່ ແລະ ທີ່ຢູ່ ຂອງເຈົ້າຂອງ (Owner Name and Address)
- (72) ຊື່ຜູ້ອອກແບບ (Designer Name)
- (74) ຊື່ຕົວແທນ (Representative Name)
- (55) ຮູບພາບ (Pictures)

ພາກທີ II
(Part II)
ແບບອຸດສາຫະກຳ
(Industrial Design)

2. ຜົນການຈົດທະບຽນ
(Registration)

ຄຳອະທິບາຍກ່ຽວກັບລະຫັດຫຍໍ້
(Introduction of Codes)

- (11) ເລກທີ ຈົດທະບຽນ (Registration Number)
- (15) ວັນທີ ຈົດທະບຽນ (Registration Date)
- (21) ເລກທີ ຍືນຄຳຮ້ອງ (Filing Number)
- (22) ວັນທີ ຍືນຄຳຮ້ອງ (Filing Date)
- (30) ວັນທີ ບຸລິມາສິດ (Priority Date)
- (17) ວັນທີ ໝົດອາຍຸ (Expiration Date)
- (51) ໝວດ (Locarno Classification)
- (54) ຊື່ຂອງແບບອຸດສາຫະກຳ (Title)
- (71) ຊື່ ແລະ ທີ່ຢູ່ ຂອງເຈົ້າຂອງ (Owner Name and Address)
- (72) ຊື່ຜູ້ອອກແບບ (Designer Name)
- (74) ຊື່ຕົວແທນ (Representative Name)
- (55) ຮູບພາບ (Pictures)

ພາກທີ II

(Part II)

ແບບອຸດສາຫະກຳ

(Industrial Design)

3. ການປ່ຽນແປງ

(Changes)

ພາກທີ II

(Part II)

ແບບອຸດສາຫະກຳ

(Industrial Design)

4. ການດັດແກ້

(Amendments)

ພາກທີ III
(Part III)
ເຄື່ອງໝາຍການຄ້າ
Trademarks

1. ຄໍາຮ້ອງ
(Applications)

ຄໍາອະທິບາຍກ່ຽວກັບລະຫັດຫຍໍ້
(Introduction of Codes)

- (540) ເຄື່ອງໝາຍການຄ້າ (Trademark)
- (511) ໝວດ (Nice Classification)
- (210) ເລກທີ ຄໍາຮ້ອງ (Number of the application)
- (220) ວັນທີ ຄໍາຮ້ອງ (Date of filing of the application)
- (732) ຊື່ ແລະ ທີ່ຢູ່ ຂອງຜູ້ຍື່ນຄໍາຮ້ອງ (Name and Address of applicant)

(540)



(511) 25, 41 and 42

(210) No. 46310

(220) 11/10/2021

(732) ບໍລິສັດ ອະຣິຍະ ຈຳກັດຜູ້ດຽວ
ຖະໜົນ ຝລັ່ງຊິວງິນ, ບ້ານ ມີໄຊ, ເມືອງຈັນທະບູລີ,
ນະຄອນຫຼວງວຽງຈັນ, ສປປ ລາວ

ພາກທີ III

(Part III)

ເຄື່ອງໝາຍການຄ້າ

Trademarks

2. ຜົນການຈົດທະບຽນ

(Registration)

ຄຳອະທິບາຍກ່ຽວກັບລະຫັດຫຍໍ້

(Introduction of Codes)

- (540) ເຄື່ອງໝາຍການຄ້າ (Trademark)
- (511) ໝວດ (Nice Classification)
- (210) ເລກທີ ຄຳຮ້ອງ (Number of the application)
- (220) ວັນທີ ຄຳຮ້ອງ (Date of filing of the application)
- (732) ຊື່ ແລະ ທີ່ຢູ່ ຂອງຜູ້ຍື່ນຄຳຮ້ອງ (Name and Address of applicant)
- (111) ເລກທີ ການຈົດທະບຽນເຄື່ອງໝາຍການຄ້າ (Number of the registration)
- (180) ວັນໝົດອາຍຸຂອງການຈົດທະບຽນ (Expiration date of the registration)

(540)



(511) 06, 07 and 17

(210) No. 45681

(220) 24/03/2021

(732) KITZ CORPORATION

10-1, Nakase 1-chome, Mihama-ku, Chiba-shi, Chiba, 261-8577, Japan

(111) No. 55195

(180) 24/03/2031

(540)



(511) 02

(210) No. 45599

(220) 04/03/2021

(732) R.J. LONDON CHEMICALS INDUSTRIES
CO., LTD.

NO.42/14 MU 14, SUWINTAWONG
ROAD, TAMBOL SALADANG, AMPHUR
BANGNAMPRIEW, CHACHOENGSAO
PROVINCE, THAILAND.

(111) No. 55196

(180) 04/03/2031

(540)

VASELINE
HEALTHY BRIGHT

(511) 03

(210) No. 44245

(220) 10/02/2020

(732) Unilever N.V.

Weena 455, 3013 AL, Rotterdam, Netherland

(111) No. 55197

(180) 10/02/2030

ພາກທີ III
(Part III)
ເຄື່ອງໝາຍການຄ້າ
Trademarks

3. ການຕໍ່ອາຍຸ
(Renewal)

ຄຳອະທິບາຍກ່ຽວກັບລະຫັດຫຍໍ້
(Introduction of Codes)

- (540) ເຄື່ອງໝາຍການຄ້າ (Trademark)
- (511) ໝວດ (Nice Classification)
- (210) ເລກທີ ຄຳຮ້ອງ (Number of the application)
- (220) ວັນທີ ຄຳຮ້ອງ (Date of filing of the application)
- (732) ຊື່ ແລະ ທີ່ຢູ່ ຂອງຜູ້ຍື່ນຄຳຮ້ອງ (Name and Address of applicant)
- (111) ເລກທີການຈັດທະບຽນເຄື່ອງໝາຍການຄ້າ (Number of the registration)
- (180) ການຕໍ່ອາຍຸການຈັດທະບຽນ (Expiration date of the renewal)

(540) Renewal



(511) 04, 07 and 12

(210) No. 876

(220) 25/05/1992

(732) Suzuki Motor Corporation

300 Takatsuka-cho, Minami-ku Hamamatsu-
shi, Shizuoka-ken, Japan

(111) No. 849

(180) 25/05/2042

(540) Renewal



(511) 04, 07 and 12

(210) No. 876

(220) 25/05/1992

(732) Suzuki Motor Corporation

300 Takatsuka-cho, Minami-ku Hamamatsu-
shi, Shizuoka-ken, Japan

(111) No. 849

(180) 25/05/2052

(540) Renewal



(511) 04, 07 and 12

(210) No. 876

(220) 25/05/1992

(732) Suzuki Motor Corporation

300 Takatsuka-cho, Minami-ku Hamamatsu-
shi, Shizuoka-ken, Japan

(111) No. 849

(180) 25/05/2032

(540) Renewal

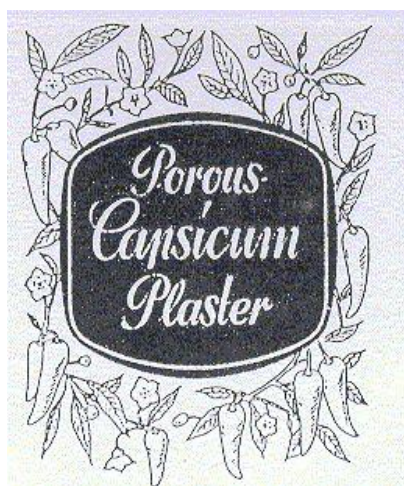

(511) 16

(210) No. 1049

(220) 22/06/1992

(732) ASTRABON (S) PTE LTD

1 Commonwealth Lane, #06-03 One
Commonwealth, 149544, Singapore

(111) No. 1017

(180) 22/06/2032

(540) Renewal

NEULASTA

(511) 05

(210) No. 9402

(220) 05/06/2002

(732) Amgen Inc

One Amgen Center drive, Thousand Oaks,
California 91320-1799,
United States of America

(111) No. 8932

(180) 09/09/2042

(540) Renewal



(511) 29

(210) No. 9486

(220) 21/06/2002

(732) VISSAN JOINT STOCK COMPANY

420 No Trang Long, Binh Thanh District, Ho
Chi Minh City, Vietnam

(111) No. 9016

(180) 08/09/2042

(540) Renewal

BRASH

(511) 03

(210) No. 25079

(220) 21/11/2011

(732) Payless ShoeSource Worldwide, INC.

Jayhawk Towers, 700 Southwest Jackson
Street, Suite 202, Topeka, Kansas 66603,
United States of America

(111) No. 24412

(180) 21/11/2031

(540) Renewal

BRASH

(511) 09

(210) No. 25080

(220) 21/11/2011

(732) Payless ShoeSource Worldwide, INC.

Jayhawk Towers, 700 Southwest Jackson
Street, Suite 202, Topeka, Kansas 66603,
United States of America

(111) No. 24413

(180) 21/11/2031

(540) Renewal

BRASH

(511) 14

(210) No. 25081

(220) 21/11/2011

(732) PAYLESS SHOESOURCE WORLDWIDE,
INC.

Jayhawk Towers, 700 Southwest Jackson
Street, Suite 202, Topeka, Kansas
66603, United States of America

(111) No. 24414

(180) 21/11/2031

(540) Renewal

BRASH

(511) 18

(210) No. 25082

(220) 21/11/2011

(732) PAYLESS SHOESOURCE WORLDWIDE,
INC.

Jayhawk Towers, 700 Southwest Jackson
Street, Suite 202, Topeka, Kansas
66603, United States of America

(111) No. 24415

(180) 21/11/2031

(540) Renewal

BRASH

(511) 25

(210) No. 25083

(220) 21/11/2011

(732) PAYLESS SHOESOURCE WORLDWIDE,
INC.

Jayhawk Towers, 700 Southwest Jackson
Street, Suite 202, Topeka, Kansas
66603, United States of America

(111) No. 24416

(180) 21/11/2031

(540) Renewal

BRASH

(511) 26

(210) No. 25084

(220) 21/11/2011

(732) PAYLESS SHOESOURCE WORLDWIDE,
INC.

Jayhawk Towers, 700 Southwest Jackson
Street, Suite 202, Topeka, Kansas
66603, United States of America

(111) No. 24417

(180) 21/11/2031

(540) Renewal

CITY SNEAKS

(511) 25

(210) No. 25086

(220) 21/11/2011

(732) PAYLESS SHOESOURCE WORLDWIDE,
INC.

Jayhawk Towers, 700 Southwest Jackson
Street, Suite 202, Topeka, Kansas
66603, United States of America

(111) No. 24419

(180) 21/11/2031

(540) Renewal

CROSS TREKKERS

(511) 25

(210) No. 25088

(220) 21/11/2011

(732) PAYLESS SHOESOURCE WORLDWIDE,
INC.

Jayhawk Towers, 700 Southwest Jackson
Street, Suite 202, Topeka, Kansas
66603, United States of America

(111) No. 24421

(180) 21/11/2031

(540) Renewal

Fioni

(511) 25

(210) No. 25089

(220) 21/11/2011

(732) PAYLESS SHOESOURCE WORLDWIDE,
INC.

Jayhawk Towers, 700 Southwest Jackson
Street, Suite 202, Topeka, Kansas
66603, United States of America

(111) No. 24422

(180) 21/11/2031

(540) Renewal

HUNTER'S BAY

(511) 25

(210) No. 25090

(220) 21/11/2011

(732) PAYLESS SHOESOURCE WORLDWIDE,
INC.

Jayhawk Towers, 700 Southwest Jackson
Street, Suite 202, Topeka, Kansas
66603, United States of America

(111) No. 24423

(180) 21/11/2031

(540) Renewal

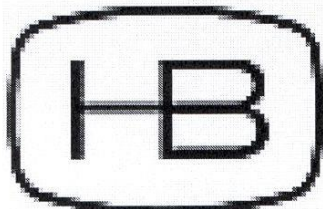

(511) 25

(210) No. 25091

(220) 21/11/2011

(732) PAYLESS SHOESOURCE WORLDWIDE,
INC.

Jayhawk Towers, 700 Southwest Jackson
Street, Suite 202, Topeka, Kansas
66603, United States of America

(111) No. 24424

(180) 21/11/2031

(540) Renewal

I LOVE SHOES

(511) 35

(210) No. 25092

(220) 21/11/2011

(732) PAYLESS SHOESOURCE WORLDWIDE,
INC.

United States of America

(111) No. 24425

(180) 21/11/2031

(540) Renewal



I LOVE SHOES

(511) 35

(210) No. 25093

(220) 21/11/2011

(732) PAYLESS SHOESOURCE WORLDWIDE,
INC.

Jayhawk Towers, 700 Southwest Jackson
Street, Suite 202, Topeka, Kansas
66603, United States of America

(111) No. 24426

(180) 21/11/2031

(540) Renewal

LOWER EAST SIDE

(511) 14

(210) No. 25094

(220) 21/11/2011

(732) PAYLESS SHOESOURCE WORLDWIDE,
INC.

Jayhawk Towers, 700 Southwest Jackson
Street, Suite 202, Topeka, Kansas
66603, United States of America

(111) No. 24427

(180) 21/11/2031

(540) Renewal

LOWER EAST SIDE

(511) 18

(210) No. 25095

(220) 21/11/2011

(732) PAYLESS SHOESOURCE WORLDWIDE,
INC.

Jayhawk Towers, 700 Southwest Jackson
Street, Suite 202, Topeka, Kansas
66603, United States of America

(111) No. 24428

(180) 21/11/2031

(540) Renewal

LOWER EAST SIDE

(511) 25

(210) No. 25096

(220) 21/11/2011

(732) PAYLESS SHOESOURCE WORLDWIDE,
INC.

Jayhawk Towers, 700 Southwest Jackson
Street, Suite 202, Topeka, Kansas
66603, United States of America

(111) No. 24429

(180) 21/11/2031

(540) Renewal

LOWER EAST SIDE

(511) 26

(210) No. 25097

(220) 21/11/2011

(732) PAYLESS SHOESOURCE WORLDWIDE,
INC.

Jayhawk Towers, 700 Southwest Jackson
Street, Suite 202, Topeka, Kansas
66603, United States of America

(111) No. 24430

(180) 21/11/2031

(540) Renewal

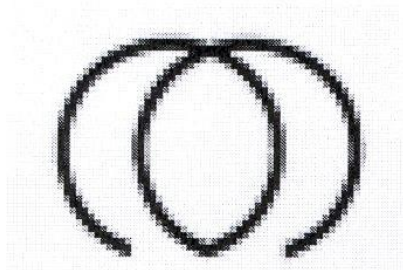

(511) 09

(210) No. 25098

(220) 21/11/2011

(732) PAYLESS SHOESOURCE WORLDWIDE,
INC.

Jayhawk Towers, 700 Southwest Jackson
Street, Suite 202, Topeka, Kansas
66603, United States of America

(111) No. 24431

(180) 21/11/2031

(540) Renewal

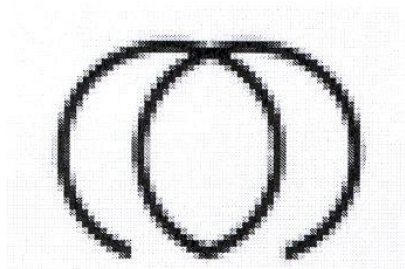

(511) 14

(210) No. 25099

(220) 21/11/2011

(732) PAYLESS SHOESOURCE WORLDWIDE,
INC.

Jayhawk Towers, 700 Southwest Jackson
Street, Suite 202, Topeka, Kansas
66603, United States of America

(111) No. 24432

(180) 21/11/2031

(540) Renewal

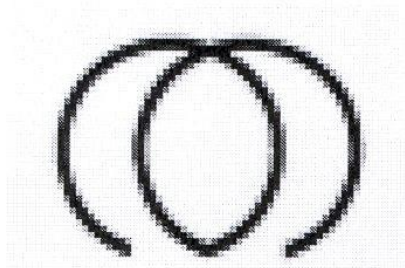

(511) 18

(210) No. 25100

(220) 21/11/2011

(732) PAYLESS SHOESOURCE WORLDWIDE,
INC.

Jayhawk Towers, 700 Southwest Jackson
Street, Suite 202, Topeka, Kansas
66603, United States of America

(111) No. 24433

(180) 21/11/2031

(540) Renewal

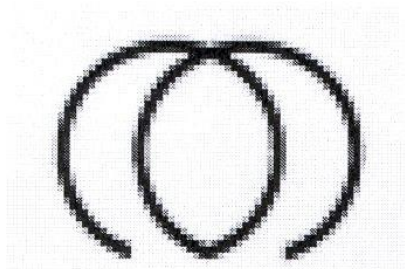

(511) 25

(210) No. 25101

(220) 21/11/2011

(732) PAYLESS SHOESOURCE WORLDWIDE,
INC.

Jayhawk Towers, 700 Southwest Jackson
Street, Suite 202, Topeka, Kansas
66603, United States of America

(111) No. 24434

(180) 21/11/2031

(540) Renewal

MINICCI

(511) 09

(210) No. 25102

(220) 21/11/2011

(732) PAYLESS SHOESOURCE WORLDWIDE,
INC.

Jayhawk Towers, 700 Southwest Jackson
Street, Suite 202, Topeka, Kansas
66603, United States of America

(111) No. 24435

(180) 21/11/2031

(540) Renewal

MINICCI

(511) 14

(210) No. 25103

(220) 21/11/2011

(732) PAYLESS SHOESOURCE WORLDWIDE,
INC.

Jayhawk Towers, 700 Southwest Jackson
Street, Suite 202, Topeka, Kansas
66603, United States of America

(111) No. 24436

(180) 21/11/2031

(540) Renewal

MINICCI

(511) 18

(210) No. 25104

(220) 21/11/2011

(732) PAYLESS SHOESOURCE WORLDWIDE,
INC.

Jayhawk Towers, 700 Southwest Jackson
Street, Suite 202, Topeka, Kansas
66603, United States of America

(111) No. 24437

(180) 21/11/2031

(540) Renewal

MINICCI

(511) 25

(210) No. 25105

(220) 21/11/2011

(732) PAYLESS SHOESOURCE WORLDWIDE,
INC.

Jayhawk Towers, 700 Southwest Jackson
Street, Suite 202, Topeka, Kansas
66603, United States of America

(111) No. 24438

(180) 21/11/2031

(540) Renewal



(511) 25

(210) No. 25106

(220) 21/11/2011

(732) PAYLESS SHOESOURCE WORLDWIDE,
INC.

Jayhawk Towers, 700 Southwest Jackson
Street, Suite 202, Topeka, Kansas
66603, United States of America

(111) No. 24439

(180) 21/11/2031

(540) Renewal



(511) 35

(210) No. 25107

(220) 21/11/2011

(732) PAYLESS SHOESOURCE WORLDWIDE,
INC.

Jayhawk Towers, 700 Southwest Jackson
Street, Suite 202, Topeka, Kansas
66603, United States of America

(111) No. 24440

(180) 21/11/2031

(540) Renewal



(511) 25

(210) No. 25108

(220) 21/11/2011

(732) PAYLESS SHOESOURCE WORLDWIDE,
INC.

Jayhawk Towers, 700 Southwest Jackson
Street, Suite 202, Topeka, Kansas
66603, United States of America

(111) No. 24441

(180) 21/11/2031

(540) Renewal



(511) 35

(210) No. 25109

(220) 21/11/2011

(732) PAYLESS SHOESOURCE WORLDWIDE,
INC.

Jayhawk Towers, 700 Southwest Jackson
Street, Suite 202, Topeka, Kansas
66603, United States of America

(111) No. 24442

(180) 21/11/2031

(540) Renewal

PLUSHEEZ

(511) 25

(210) No. 25110

(220) 21/11/2011

(732) PAYLESS SHOESOURCE WORLDWIDE,
INC.

Jayhawk Towers, 700 Southwest Jackson
Street, Suite 202, Topeka, Kansas
66603, United States of America

(111) No. 24443

(180) 21/11/2031

(540) Renewal

PREDICTIONS

(511) 25

(210) No. 25111

(220) 21/11/2011

(732) PAYLESS SHOESOURCE WORLDWIDE,
INC.

Jayhawk Towers, 700 Southwest Jackson
Street, Suite 202, Topeka, Kansas
66603, United States of America

(111) No. 24444

(180) 21/11/2031

(540) Renewal

The logo for ProSprints, featuring a stylized swoosh above the word "ProSprints" in a bold, sans-serif font.

(511) 25

(210) No. 25112

(220) 21/11/2011

(732) PAYLESS SHOESOURCE WORLDWIDE,
INC.

Jayhawk Towers, 700 Southwest Jackson
Street, Suite 202, Topeka, Kansas
66603, United States of America

(111) No. 24445

(180) 21/11/2031

(540) Renewal

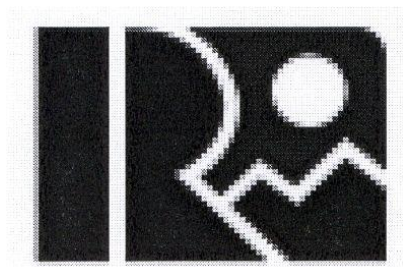

(511) 25

(210) No. 25113

(220) 21/11/2011

(732) PAYLESS SHOESOURCE WORLDWIDE,
INC.

Jayhawk Towers, 700 Southwest Jackson
Street, Suite 202, Topeka, Kansas
66603, United States of America

(111) No. 24446

(180) 21/11/2031

(540) Renewal

**RUGGED
OUTBACK**

(511) 25

(210) No. 25114

(220) 21/11/2011

(732) PAYLESS SHOESOURCE WORLDWIDE,
INC.

Jayhawk Towers, 700 Southwest Jackson
Street, Suite 202, Topeka, Kansas
66603, United States of America

(111) No. 24447

(180) 21/11/2031

(540) Renewal

SMART FIT

(511) 25

(210) No. 25115

(220) 21/11/2011

(732) PAYLESS SHOESOURCE WORLDWIDE,
INC.

Jayhawk Towers, 700 Southwest Jackson
Street, Suite 202, Topeka, Kansas
66603, United States of America

(111) No. 24448

(180) 21/11/2031

(540) Renewal

STATE STREET

(511) 25

(210) No. 25116

(220) 21/11/2011

(732) PAYLESS SHOESOURCE WORLDWIDE,
INC.

Jayhawk Towers, 700 Southwest Jackson
Street, Suite 202, Topeka, Kansas
66603, United States of America

(111) No. 24449

(180) 21/11/2031

(540) Renewal

SAFE T STEP

(511) 25

(210) No. 25117

(220) 21/11/2011

(732) PAYLESS SHOESOURCE WORLDWIDE,
INC.

Jayhawk Towers, 700 Southwest Jackson
Street, Suite 202, Topeka, Kansas
66603, United States of America

(111) No. 24450

(180) 21/11/2031

(540) Renewal

SPOTLIGHTS

(511) 25

(210) No. 25120

(220) 21/11/2011

(732) PAYLESS SHOESOURCE WORLDWIDE,
INC.

Jayhawk Towers, 700 Southwest Jackson
Street, Suite 202, Topeka, Kansas
66603, United States of America

(111) No. 24453

(180) 21/11/2031

(540) Renewal

TEENY TOES

(511) 25

(210) No. 25121

(220) 21/11/2011

(732) PAYLESS SHOESOURCE WORLDWIDE,
INC.

Jayhawk Towers, 700 Southwest Jackson
Street, Suite 202, Topeka, Kansas
66603, United States of America

(111) No. 24454

(180) 21/11/2031

(540) Renewal

**UNFORGETTABLE
MOMENTS**

(511) 03

(210) No. 25122

(220) 21/11/2011

(732) PAYLESS SHOESOURCE WORLDWIDE,
INC.

Jayhawk Towers, 700 Southwest Jackson
Street, Suite 202, Topeka, Kansas
66603, United States of America

(111) No. 24455

(180) 21/11/2031

(540) Renewal

**UNFORGETTABLE
MOMENTS**

(511) 18

(210) No. 25123

(220) 21/11/2011

(732) PAYLESS SHOESOURCE WORLDWIDE,
INC.

Jayhawk Towers, 700 Southwest Jackson
Street, Suite 202, Topeka, Kansas
66603, United States of America

(111) No. 24456

(180) 21/11/2031

(540) Renewal

**UNFORGETTABLE
MOMENTS**

(511) 25

(210) No. 25124

(220) 21/11/2011

(732) PAYLESS SHOESOURCE WORLDWIDE,
INC.

Jayhawk Towers, 700 Southwest Jackson
Street, Suite 202, Topeka, Kansas
66603, United States of America

(111) No. 24457

(180) 21/11/2031

(540) Renewal

ZOE & ZAC

(511) 03

(210) No. 25125

(220) 21/11/2011

(732) PAYLESS SHOESOURCE WORLDWIDE,
INC.

Jayhawk Towers, 700 Southwest Jackson
Street, Suite 202, Topeka, Kansas
66603, United States of America

(111) No. 24458

(180) 21/11/2031

(540) Renewal

ZOE & ZAC

(511) 14

(210) No. 25126

(220) 21/11/2011

(732) PAYLESS SHOESOURCE WORLDWIDE,
INC.

Jayhawk Towers, 700 Southwest Jackson
Street, Suite 202, Topeka, Kansas
66603, United States of America

(111) No. 24459

(180) 21/11/2031

(540) Renewal

ZOE & ZAC

(511) 18
(210) No. 25127
(220) 21/11/2011
(732) PAYLESS SHOESOURCE WORLDWIDE,
INC.
Jayhawk Towers, 700 Southwest Jackson
Street, Suite 202, Topeka, Kansas
66603, United States of America
(111) No. 24460
(180) 21/11/2031

(540) Renewal

ZOE & ZAC

(511) 25
(210) No. 25128
(220) 21/11/2011
(732) PAYLESS SHOESOURCE WORLDWIDE,
INC.
Jayhawk Towers, 700 Southwest Jackson
Street, Suite 202, Topeka, Kansas
66603, United States of America
(111) No. 24461
(180) 21/11/2031

(540) Renewal

**MONTEGO BAY
CLUB**

(511) 25

(210) No. 25133

(220) 21/11/2011

(732) PAYLESS SHOESOURCE WORLDWIDE,
INC.

Jayhawk Towers, 700 Southwest Jackson
Street, Suite 202, Topeka, Kansas
66603, United States of America

(111) No. 24466

(180) 21/11/2031

(540) Renewal

**PAYLESS
SHOESOURCE**

(511) 25

(210) No. 25134

(220) 21/11/2011

(732) PAYLESS SHOESOURCE WORLDWIDE,
INC.

Jayhawk Towers, 700 Southwest Jackson
Street, Suite 202, Topeka, Kansas
66603, United States of America

(111) No. 24467

(180) 21/11/2031

(540) Renewal

**PAYLESS
SHOESOURCE**

(511) 35

(210) No. 25135

(220) 21/11/2011

(732) PAYLESS SHOESOURCE WORLDWIDE,
INC.

Jayhawk Towers, 700 Southwest Jackson
Street, Suite 202, Topeka, Kansas
66603, United States of America

(111) No. 24468

(180) 21/11/2031

(540) Renewal

Think for the better

(511) 16

(210) No. 26331

(220) 04/05/2012

(732) SCG Packaging Public Company Limited
1 Siam Cement Road, Bangsue Sub-district,
Bangsue District, Bangkok, Thailand

(111) No. 25644

(180) 13/11/2032

(540) Renewal

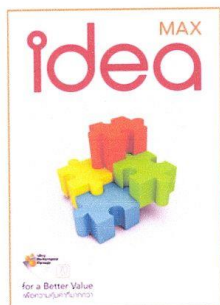

(511) 16

(210) No. 26332

(220) 04/05/2012

(732) SCG Packaging Public Company Limited
1 Siam Cement Road, Bangsue Sub-district,
Bangsue District, Bangkok, Thailand

(111) No. 25645

(180) 13/11/2032

(540) Renewal



Miscellaneous Design

(511) 05

(210) No. 9401

(220) 05/06/2002

(732) Amgen Inc.
One Amgen Center Drive Thousand Oaks,
California 91320-1789,
United States of America

(111) No. 32572

(180) 05/06/2032

ພາກທີ III

(Part III)

ເຄື່ອງໝາຍການຄ້າ

Trademarks

4. ການປ່ຽນແປງ

(Changes)

ພາກທີ III
(Part III)
ເຄື່ອງໝາຍການຄ້າ
Trademarks

5. ການດັດແກ້
(Amendments)

ພາກທີ IV
(Part IV)

ເຄື່ອງໝາຍການຄ້າຜ່ານລະບົບມາດຣິດ
Trademarks via Madrid Protocol

1. ຄໍາຮ້ອງ
(Applications)

ຄໍາອະທິບາຍກ່ຽວກັບລະຫັດຫຍໍ້
(Introduction of Codes)

- (540) ເຄື່ອງໝາຍການຄ້າ (Trademark)
- (511) ໝວດ (Nice Classification)
- (210) ເລກທີ ຄໍາຮ້ອງ (Number of the application)
- (220) ວັນທີ ຄໍາຮ້ອງ (Date of filing of the application)
- (732) ຊື່ ແລະ ທີ່ຢູ່ ຂອງຜູ້ຍື່ນຄໍາຮ້ອງ (Name and Address of applicant)

(540)

GROWPLUS

(511) 05, 29 and 30

(210) No. M/1510344

(220) 30/06/2022

(732) NUTIFOOD NUTRITION FOOD JOINT
STOCK COMPANY

281-283 Hoang Dieu, Ward 6, District 4 Ho
Chi Minh City, Vietnam

(540)

FAMNA

(511) 05, 29, 30 and 32

(210) No. M/1637782

(220) 08/06/2022

(732) NUTIFOOD NUTRITION FOOD JOINT
STOCK COMPANY

281-283 Hoang Dieu, Ward 6, District 4 Ho
Chi Minh City, Vietnam

(540)

The logo consists of the letters 'NUVI' in a bold, 3D, sans-serif font. The letters are white with a grey shadow on the right side, giving them a three-dimensional appearance.

(511) 05, 29, 30 and 32

(210) No. M/1637783

(220) 29/06/2022

(732) NUTIFOOD NUTRITION FOOD JOINT
STOCK COMPANY

281-283 Hoang Dieu, Ward 6, District 4 Ho
Chi Minh City, Vietnam

(540)

The logo is the word 'VÄRNA' in a bold, black, sans-serif font. The 'A' has a small 'V' above it, and the 'R' has a small 'A' above it, which are part of the brand's typographic design.

(511) 05, 29, 30 and 32

(210) No. M/1637784

(220) 08/06/2022

(732) NUTIFOOD NUTRITION FOOD JOINT
STOCK COMPANY

281-283 Hoang Dieu, Ward 6, District 4 Ho
Chi Minh City, Vietnam

(540)

Crystal Crown

(511) 09, 28 and 41

(210) No. M/1679953

(220) 28/04/2022

(732) Euro Games Technology Ltd.

4, "Maritsa" Str., "Vranya-Lozen-Triugulnika"
BG-1151 Sofia, Bulgaria

(540)

Flaming Win

(511) 09, 28 and 41

(210) No. M/1679954

(220) 28/04/2022

(732) Euro Games Technology Ltd.

4, "Maritsa" Str., "Vranya-Lozen-Triugulnika"
BG-1151 Sofia, Bulgaria

(540)

Burning Crystal

(511) 09, 28 and 41

(210) No. M/1679957

(220) 28/04/2022

(732) Euro Games Technology Ltd.

4, "Maritsa" Str., "Vranya-Lozen-Triugulnika"
BG-1151 Sofia, Bulgaria

(540)

PowMr

(511) 09

(210) No. M/1680138

(220) 28/06/2022

(732) SHENZHEN HEHEJIN INDUSTRIAL
CO.,LTD.

Room A1001-2, 10th Floor, Building A,
Rongde International, Huaqiao Village,
Henggang Street, Longgang District,
Shenzhen 518100 Guangdong, China

(540)

bmtl

(511) 09

(210) No. M/1680150

(220) 06/06/2022

(732) Shenzhen Sinoband Electric Co., Ltd
Room 408, Building 7#, Longcheng Industrial
Zone, Gaofeng Community, Dalang Street,
Longhua District, Shenzhen City 518000
Guangdong Province, China

(540)

DMEGC

(511) 07, 09 and 12

(210) No. M/1680198

(220) 10/06/2022

(732) Hengdian Group DMEGC Magnetics Co.,
Ltd.
Hengdian Industrial Area, Dongyang City
322100 Zhejiang Province, China

(540)

υAiFI

(511) 09, 10 and 42

(210) No. M/1680211

(220) 30/05/2022

(732) Shanghai United Imaging Healthcare Co.,
Ltd.

No. 2258 Chengbei Rd., Jiading District
Shanghai, China

(540)

**弗列加特
FREGATE**

(511) 31

(210) No. M/1680226

(220) 28/06/2022

(732) Gambol Pet Group Co., Ltd.

No. 8 Mudanjiang Rd., Economic and
Technological Development Zone, Liaocheng
252000 Shandong Province, China

(540)



(511) 41

(210) No. M/1680231

(220) 13/07/2022

(732) Shenzhen city Yiquan Education Consulting Co., Ltd.

(settled in Shenzhen Qianhai Business Secretary Co., LTD.) Room 201, Building A, No. 1 Qianwan First Road, Qianhai Shenzhen-Hong Kong Cooperation Zone Shenzhen, China

(540)

AnyBuds

(511) 09

(210) No. M/1680238

(220) 07/06/2022

(732) Shenzhen Worgo Technology Limited

2601-2603, 2606-2607, Building 1, Zhongliang Chuangxin R&D Center, 69 District, Xingdong Community, Xinan Street, Baoan District, Shenzhen City 518000 Guangdong, China

(540)



(511) 09

(210) No. M/1680246

(220) 20/06/2022

(732) Shenzhen Heiston Photoelectric Technology
Co., Ltd

401, Building G, No. 17, Xintian Community
Innovation Industrial Park, Guanhu Street,
Longhua District, Shenzhen Guangdong,
China

(540)

Truesonic

(511) 09

(210) No. M/1680250

(220) 21/06/2022

(732) Shenzhen Tozo Technology Limited

Room 402, Education Industry Building,
District 71, Xingdong Community, Xin'an
Street, Bao'an District 518000 Shenzhen,
China

(540)



(511) 09

(210) No. M/1680260

(220) 12/07/2022

(732) Shenzhen Wesion Technology Co., Ltd.

D#2101A, 2101B, 2102F Caifugang

International Building, No. 1084, Baoyuan

Road, Yuye Community, Xixiang Street,

Baoan District, Shenzhen 518100 Guangdong

Province, China

(540)



(511) 20

(210) No. M/1680271

(220) 13/07/2022

(732) Foshan Sitzone Furniture Co.,Ltd.

No.8, Chaohai Road, Xiqing Village,

Longjiang Town, Shunde District, Foshan

City Guangdong Province, China

(540)



EAPharma

(511) 05, 42 and 44

(210) No. M/1680277

(220) 13/07/2022

(732) EA Pharma Co., Ltd.

2-1-1, Irifune, Chuo-ku Tokyo 104-0042,
Japan

(540)

ZARA ORIGINS

(511) 09, 14, 18 and 25

(210) No. M/1680305

(220) 08/02/2022

(732) INDUSTRIA DE DISEÑO TEXTIL, S.A.

(INDITEX, S.A.)

Avenida de la Diputación "Edificio Inditex" E-
15142 Arteixo (A Coruña), Spain

(540)

ATOUCH
At your heart

(511) 09

(210) No. M/1680395

(220) 22/07/2022

(732) Shenzhen City HongLiXinDa Electron
Co.,Ltd

B4501B, Building 18, Junfeng Industrial
Park, Chongqing Road, Heping Community,
Fuhai Street, Baoan District, Shenzhen
GuangDong, China

(540)

BORRAS
GRIFERIAS

(511) 11

(210) No. M/1680399

(220) 15/07/2022

(732) ZHEJIANG KANGYI SANITARY WARE
CO., LTD.

Qinggang Industrial Cluster, Yuhuan,
Taizhou Zhejiang Province, China

(540)

聖葉

(511) 34

(210) No. M/1680406

(220) 28/06/2022

(732) LI YAN QIANG

Room 613A, Building 1, No. 326, Lovers
North Road, Xiangzhou District, Zhuhai City
430000 Guangdong Province, China

(540)

东工

(511) 11

(210) No. M/1680413

(220) 06/07/2022

(732) Sichuan Dongfang Boiler Industry Boiler

Group Co., Ltd

Huangjia Mountain, Da'an District, Zigong
City 643000 Sichuan Province, China

(540)

HOGUO

(511) 09

(210) No. M/1680415

(220) 02/08/2022

(732) Shenzhen Welixun Electronics Co.,LTD.

B Area, 3F, Building C15, Fuyuan Industrial
Park, NO.598, Zhoushi Road, Jiuwei
Community, Hangcheng Street, Bao'an Dist.,
Shenzhen 518000 Guangdong, China

(540)

VivaChek

(511) 05, 10 and 44

(210) No. M/1680416

(220) 24/06/2022

(732) VivaChek Biotech (Hangzhou) Co., Ltd.

Level 2, Block 2, 146 East Chaofeng Road,
Yuhang Economy Development Zone,
Hangzhou 310000 Zhejiang, China

(540)

KEVIN&COCO

(511) 03

(210) No. M/1680491

(220) 25/05/2022

(732) Ding Yuying

No. 798, Group 1, Chenguang Village, Yilaha
Town, Nenjiang County, Heihe City 161437
Heilongjiang Province, China

(540)

VINFAST VF 5

(511) 12

(210) No. M/1680533

(220) 19/01/2022

(732) Vingroup Joint Stock Company

No. 7, Bang Lang 1 Street, Vinhomes
Riverside Ecological Urban Area, Viet Hung
Ward, Long Bien District Hanoi City,
Vietnam

(540)

silencare

(511) 11

(210) No. M/1680627

(220) 12/07/2022

(732) CUORI ELECTRICAL APPLIANCES
(GROUP) CO. LTD.

No.48, Developing Road, Zhouxiang Town,
Cixi City Zhejiang, China

(540)

Tcomma

(511) 29 and 43

(210) No. M/1680630

(220) 21/06/2022

(732) Nanjing Comma Brand Management Co.,
Ltd.

4th Floor, Huaying International Building,
No. 9 Jinluan Lane, Qinhuai District, Nanjing
City Jiangsu Province, China

(540)

Engula

(511) 09, 35 and 42

(210) No. M/1680636

(220) 28/06/2022

(732) Yunnai (Beijing) Technology Development
Co., Ltd.

1128-90, 11/F, No. 18, Zhongguancun Street,
Haidian District 100089 Beijing, China

(540)

Burning Eye

(511) 09, 28 and 41

(210) No. M/1680641

(220) 14/04/2022

(732) Euro Games Technology Ltd.

"Maritsa" Str. 4, "Vranya-Lozen-Triugulnika"
BG-1151 Sofia, Bulgaria

(540)

Lord

(511) 26

(210) No. M/1680687

(220) 05/08/2022

(732) Lordhair (Qingdao) Co., Ltd

B-807, Lubang Plaza, No. 177, Shandong
Road, Shibe District, Qingdao City
Shandong Province, China

(540)

AOSKEY

(511) 09

(210) No. M/1680712

(220) 03/08/2022

(732) Shenzhen Honto Innovation Technology Co.,
Ltd

Room 602-603, Building 3, Minle Industrial
Zone, Minle Community, Minzhi Street,
Longhua District, Shenzhen City 518000
Guangdong Province, China

(540)

PTAC

(511) 09, 35 and 38

(210) No. M/1680724

(220) 11/04/2022

(732) China National Postal and
Telecommunications Appliances Co., Ltd
No.156, Fuxingmennei Street, Xicheng
District 100031 Beijing, China

(540)

SevenCat

(511) 09

(210) No. M/1680754

(220) 17/06/2022

(732) Shanghai Sevenscat Cultural Media Co.,Ltd.
Room 114, No.128, Shexin Road, Sheshan
Town, Songjiang District 201602 Shanghai,
China

(540)



(511) 31

(210) No. M/1680755

(220) 28/06/2022

(732) Gambol Pet Group Co., Ltd.

No. 8 Mudanjiang Rd., Economic and
Technological Development Zone, Liaocheng
252000 Shandong Province, China

(540)



(511) 41

(210) No. M/1680759

(220) 28/06/2022

(732) Wang Yuhong

Group 8, Leju Committee, Dongchang Street,
Dongchang District, Tonghua City 134000
Jilin Province, China

(540)



(511) 39

(210) No. M/1680865

(220) 21/06/2022

(732) China Cargo Airlines Ltd.

No. 1279 Hangcheng Road, Jichang Zhen,
Pudong New District Shanghai, China

(540)

稀物集

(511) 03

(210) No. M/1680896

(220) 29/06/2022

(732) Guangzhou Anyoumei Corporation

Management Co.,Ltd.

Room 2803, No. 888 Yuncheng West Road,
Baiyun District, Guangzhou City Guangdong
Province, China

(540)



(511) 34

(210) No. M/1680981

(220) 15/06/2022

(732) SOODESSH A/L NANAPERAKASAM

trading as RESURGENCE HILLS

ENTERPRISE

102A-3B Jalan PJU 1/3B, Sunwaymas

Commercial Center 47301 Petaling Jaya

Selangor, Malaysia

(540)

ZHONGNANHAI

(511) 34

(210) No. M/1680989

(220) 20/06/2022

(732) Shanghai Tobacco Group Beijing Cigarette

Factory Co.,Ltd.

No. 99, WanSheng NanJie TongZhou District

101121 Beijing, China

(540)

MYLUMO

(511) 05

(210) No. M/1681020

(220) 04/08/2022

(732) Vyluma Inc.

1019 US Highway 202-206 Bridgewater NJ
08807, United States of America

(540)



渝富源

(511) 01

(210) No. M/1681034

(220) 11/07/2022

(732) Chongqing Fuyuan Chemical Co., Ltd

No. 100, Yantai Avenue, Yantai Town,
Dianjiang County, Chongqing, China

(540)

VALEO

(511) 01, 02, 03, 04, 05, 06, 07, 09, 11, 12, 35, 36,
37, 38, 39, 41, 42 and 44

(210) No. M/1681041

(220) 01/02/2022

(732) VALEO

43, rue Bayen F-75017 Paris, France

(540)



(511) 42

(210) No. M/1681067

(220) 29/04/2022

(732) INFOBIP d.o.o. za informatičke usluge

Istarska ulica - Via dell'Istria 157 HR-52215

Vodnjan-Dignano, Croatia (Local Name:

Hrvatska)

(540)



(511) 29, 30, 31, 35, 39 and 43

(210) No. M/1681068

(220) 21/07/2022

(732) Obshchestvo s Ogranichennoy

Otvetstvennostyu «Denir»

ul. Lenina, 75 s. Pavlovskaya Sloboda g. Istra

RU-143581 Moskovskaya obl., Russian

Federation

ພາກທີ IV

(Part IV)

ເຄື່ອງໝາຍການຄ້າຜ່ານລະບົບມາດຣິດ

Trademarks via Madrid Protocol

2. ຜົນການຈົດທະບຽນ

(Registration)

ຄຳອະທິບາຍກ່ຽວກັບລະຫັດຫຍໍ້

(Introduction of Codes)

- (540) ເຄື່ອງໝາຍການຄ້າ (Trademark)
- (511) ໝວດ (Nice Classification)
- (210) ເລກທີ ຄຳຮ້ອງ (Number of the application)
- (220) ວັນທີ ຍື່ນຄຳຮ້ອງ (Date of filing of the application)
- (732) ຊື່ ແລະ ທີ່ຢູ່ ຂອງຜູ້ຍື່ນຄຳຮ້ອງ (Name and Address of applicant)
- (111) ເລກທີການຈົດທະບຽນເຄື່ອງໝາຍການຄ້າ (Number of the registration)
- (180) ວັນໝົດອາຍຸຂອງການຈົດທະບຽນ (Expiration date of the registration)

(540)

KOMATSU

(511) 14, 16, 18, 24, 25 and 28

(210) No. M/1578230

(220) 16/07/2021

(732) KOMATSU LTD.

3-6, 2-chome Akasaka, Minato-ku Tokyo

107-8414, Japan

(111) No. M/1578230

(180) 11/09/2030

(540)



(511) 12 and 37

(210) No. M/1634170

(220) 19/10/2021

(732) ZHEJIANG GEELY HOLDING GROUP

CO., LTD.

1760 Jiangling Road, Binjiang District,

Hangzhou Zhejiang, China

(111) No. M/1634170

(180) 19/10/2031

(540)

SURTEC®

(511) 07

(210) No. M/1635638

(220) 19/10/2021

(732) Jiaxing Surtec Machinery Co., Ltd

North Qianxi Rd, Group 8, Gangzhong

Village, Guangchen Town, Pinghu City

Zhejiang, China

(111) No. M/1635638

(180) 19/10/2031

(540)

王麻子

(511) 08 and 21

(210) No. M/1636817

(220) 05/02/2021

(732) Guangdong Jinhui Knife and Scissors

Incorporated company Ltd.

A8, Chicheng 8th Road, Industrial Transfer

Industrial Park, Foshan Chancheng

(Yangdong Wanxiang), Yangjiang City

Guangdong Province, China

(111) No. M/1636817

(180) 05/02/2031

(540)

NUTRICOIDE

(511) 05, 30 and 32

(210) No. M/1636937

(220) 07/02/2021

(732) FM World Sp. z o.o.

ul. Żmigrodzka 247 PL-51-129 Wrocław,
Poland

(111) No. M/1636937

(180) 07/02/2031

(540)

CRYSTAL WIN

(511) 09, 28 and 41

(210) No. M/1637019

(220) 23/07/2021

(732) Euro Games Technology Ltd.

4, "Maritsa" Str., "Vranya-Lozen-Triugulnika"
BG-1151 Sofia, Bulgaria

(111) No. M/1637019

(180) 23/07/2031

(540)

y42

(511) 35 and 42

(210) No. M/1637047

(220) 03/09/2021

(732) Datos-Intelligence GmbH

Charlottenstraße 4 10969 Berlin, Germany

(111) No. M/1637047

(180) 03/09/2031

(540)

JAEGER

(511) 03, 04, 09, 14, 18, 24, 25 and 35

(210) No. M/1637246

(220) 07/07/2021

(732) Marks and Spencer (Jaeger) Limited

Waterside House, 35 North Wharf Road

London W2 1NW, United Kingdom

(111) No. M/1637246

(180) 07/07/2031

(540)



(511) 03, 05, 10, 24 and 35

(210) No. M/1637250

(220) 09/06/2021

(732) FUJIAN NEW YIFA GROUP CO., Ltd.

Xinhan Industrial Area, Hanjiang District,

Putian City Fujian Province, China

(111) No. M/1637250

(180) 09/06/2031

(540)

HONOR Magic Fold

(511) 09

(210) No. M/1637620

(220) 03/11/2021

(732) Honor Device Co., Ltd.

Suite 3401, Unit A, Building 6, Shum Yip

Sky Park, No. 8089, Hongli West Road,

Xiangmihu Street, Futian District, Shenzhen

518040 Guangdong, China

(111) No. M/1637620

(180) 03/11/2031

(540)

HONOR Magic Flex

(511) 09

(210) No. M/1637621

(220) 03/11/2021

(732) Honor Device Co., Ltd.

Suite 3401, Unit A, Building 6, Shum Yip
Sky Park, No.8089, Hongli West Road,
Xiangmihu Street, Futian District, Shenzhen
518040 Guangdong, China

(111) No. M/1637621

(180) 03/11/2031

(540)



(511) 30 and 43

(210) No. M/1637659

(220) 05/07/2021

(732) Gao Defu

Bldg A26# of Dalian International Business
Park, No. 57 Xin Kang Yuan, La Zi Shan,
Gan Jing Zi District, Dalian City LiaoNing
Province, China

(111) No. M/1637659

(180) 05/07/2031

(540)

The logo for LINCNET features the word "LINCNET" in a bold, teal, sans-serif font. To the right of the text is a stylized orange arrow pointing upwards and to the right.

(511) 09 and 11

(210) No. M/1637810

(220) 28/09/2021

(732) ADB SAFEGATE BV

Leuvensesteenweg 585 B-1930 Zaventem,
Belgium

(111) No. M/1637810

(180) 28/09/2031

(540)



(511) 03, 05, 21, 25 and 44

(210) No. M/1637866

(220) 12/11/2021

(732) Beiersdorf AG

Unnastr. 48 20253 Hamburg, Germany

(111) No. M/1637866

(180) 12/11/2031

(540)

**LOUIS XIII THE
DROP**

(511) 33

(210) No. M/1638224

(220) 26/11/2021

(732) E. REMY MARTIN & C°

20 rue de la Société Vinicole F-16100

COGNAC, France

(111) No. M/1638224

(180) 26/11/2031

(540)

**MACOS
MONTEREY**

(511) 09

(210) No. M/1638247

(220) 12/07/2021

(732) Apple Inc.

One Apple Park Way Cupertino CA 95014,

United States of America

(111) No. M/1638247

(180) 12/07/2031

(540)

Powerfoyle

(511) 06, 07, 09, 11, 12, 14, 18, 19, 20, 25, 28, 37,
40 and 42

(210) No. M/1638531

(220) 10/05/2021

(732) Exeger Operations AB

Box 55597 SE-102 04 Stockholm, Sweden

(111) No. M/1638531

(180) 10/05/2031

(540)

 **chanyi**

(511) 16

(210) No. M/1638807

(220) 09/06/2021

(732) YIWU WENYUAN STATIONERY CO.,
LTD.

Shenzhou Road, Houzhai Industrial District,

Yiwu City 322008 Zhejiang Province, China

(111) No. M/1638807

(180) 09/06/2031

(540)

The logo for Apple's AirTag, featuring the Apple logo icon followed by the word "AirTag" in a bold, sans-serif font.

(511) 09

(210) No. M/1638850

(220) 01/11/2021

(732) Apple Inc.

One Apple Park Way Cupertino CA 95014,
United States of America

(111) No. M/1638850

(180) 01/11/2031

(540)

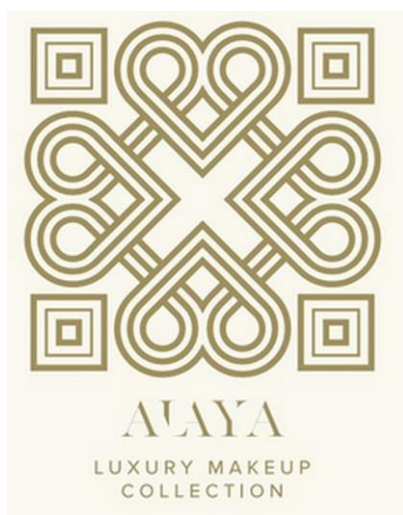

(511) 03

(210) No. M/1639015

(220) 02/03/2021

(732) FM World Sp. z o.o.

ul. Żmigrodzka 247 PL-51-129 Wrocław,
Poland

(111) No. M/1639015

(180) 02/03/2031

(540)

A SIGN OF LOVE

(511) 29, 30 and 43

(210) No. M/1639211

(220) 10/08/2021

(732) Barilla G. e R. Fratelli - Società per Azioni

Via Mantova 166 I-43122 Parma (PR), Italy

(111) No. M/1639211

(180) 10/08/2031

(540)

Cambridge ICYD

(511) 41

(210) No. M/1639270

(220) 27/08/2021

(732) Cambridge Union Society Enterprises Limited

9a Bridge Street Cambridge CB2 1UB,

United Kingdom

(111) No. M/1639270

(180) 27/08/2031

(540)

Ultra Suede

(511) 03

(210) No. M/1639596

(220) 03/12/2021

(732) LJULJA BEAUTY INC.

135 E57th Street New York NY 10022,

United States of America

(111) No. M/1639596

(180) 03/12/2031

(540)

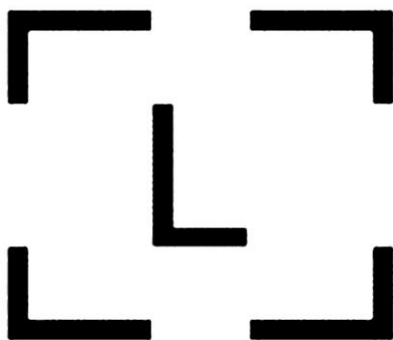

(511) 09, 36, 38 and 42

(210) No. M/1639627

(220) 20/07/2021

(732) LEDGER

1 rue du Mail F-75002 PARIS, France

(111) No. M/1639627

(180) 20/07/2031

(540)

LEDGER

(511) 06, 09, 35, 36, 38 and 42

(210) No. M/1639628

(220) 15/07/2021

(732) LEDGER

1 rue du Mail F-75002 PARIS, France

(111) No. M/1639628

(180) 15/07/2031

(540)

HelperODM

(511) 09

(210) No. M/1639846

(220) 18/11/2021

(732) Shenzhen Baijie Technology Co., Ltd.

Bao'an Internet Industry Base Area A, 5

Blocks 306, Mabu Community, Xixiang

Street, Bao'an District, Shenzhen City 518000

Guangdong Province, China

(111) No. M/1639846

(180) 18/11/2031

(540)



(511) 02 and 37

(210) No. M/1640097

(220) 08/12/2021

(732) NIPPON PAINT HOLDINGS SG PTE. LTD.

24 RAFFLES PLACE, CLIFFORD CENTRE

#20-03 048621, SINGAPORE

(111) No. M/1640097

(180) 08/12/2031

(540)



(511) 02 and 37

(210) No. M/1640165

(220) 08/12/2021

(732) NIPPON PAINT HOLDINGS SG PTE. LTD.

24 RAFFLES PLACE, CLIFFORD CENTRE

#20-03 048621, SINGAPORE

(111) No. M/1640165

(180) 08/12/2031

(540)

SWC Wälzlagerfabrikation

(511) 06 and 07

(210) No. M/1640283

(220) 07/08/2021

(732) Franz Pfennig

Am Buchweg 30 97464 Niederwernn,

Germany

(111) No. M/1640283

(180) 07/08/2031

(540)



(511) 12 and 35

(210) No. M/1640339

(220) 07/04/2021

(732) BENELLI Q.J. SRL

Strada Fornace Vecchia s.n. I-61122 Pesaro,

Italy

(111) No. M/1640339

(180) 07/04/2031

(540)

**MAKING A
DIFFERENCE ONE
WING AT A TIME**

(511) 43

(210) No. M/1640406

(220) 19/11/2021

(732) HI Limited Partnership

1815 The Exchange Atlanta GA 30339,

United States of America

(111) No. M/1640406

(180) 19/11/2031

(540)



(511) 09, 28 and 41

(210) No. M/1640577

(220) 12/08/2021

(732) Euro Games Technology Ltd.

4, "Maritsa" Str., "Vranya-Lozen-

Triugulnika" BG-1151 Sofia, Bulgaria

(111) No. M/1640577

(180) 12/08/2031

(540)

IAM

(511) 43

(210) No. M/1641006

(220) 16/12/2021

(732) HI Limited Partnership

1815 The Exchange Atlanta GA 30339,

United States of America

(111) No. M/1641006

(180) 16/12/2031

(540)

**I AM A HOOTERS
GIRL**

(511) 43

(210) No. M/1641007

(220) 16/12/2021

(732) HI Limited Partnership

1815 The Exchange Atlanta GA 30339,

United States of America

(111) No. M/1641007

(180) 16/12/2031

(540)

TELUS

(511) 09, 35, 36, 37 and 42

(210) No. M/1637647

(220) 11/05/2021

(732) TELUS CORPORATION

c/o TELUS Legal Services, 200 Consilium
Place, Suite 1600 Scarborough ON M1H3J3,
Canada

(111) No. M/1637647

(180) 11/05/2031

(540)

ELASTEN

(511) 03, 05, 29, 30 and 32

(210) No. M/1640600

(220) 15/10/2021

(732) Quiris Healthcare GmbH & Co. KG

Isselhorster Str. 260 33334 Gütersloh,
Germany

(111) No. M/1640600

(180) 15/10/2031

ພາກທີ IV

(Part IV)

ເຄື່ອງໝາຍການຄ້າຜ່ານລະບົບມາດຣິດ

Trademarks via Madrid Protocol

3. ຜົນການຕໍ່ອາຍຸ

(Renewal)

ຄຳອະທິບາຍກ່ຽວກັບລະຫັດຫຍໍ້

(Introduction of Codes)

- (540) ເຄື່ອງໝາຍການຄ້າ (Trademark)
- (511) ໝວດ (Nice Classification)
- (210) ເລກທີ ຄຳຮ້ອງ (Number of the application)
- (220) ວັນທີ ຍື່ນຄຳຮ້ອງ (Date of filing of the application)
- (732) ຊື່ ແລະ ທີ່ຢູ່ ຂອງຜູ້ຍື່ນຄຳຮ້ອງ (Name and Address of applicant)
- (111) ເລກທີການຈົດທະບຽນເຄື່ອງໝາຍການຄ້າ (Number of the registration)
- (180) ການຕໍ່ອາຍຸຂອງການຈົດທະບຽນ (Expiration date of the renewal)

ພາກທີ IV

(Part IV)

ເຄື່ອງໝາຍການຄ້າຜ່ານລະບົບມາດຣິດ

Trademarks via Madrid Protocol

4. ການປ່ຽນແປງ

(Changes)

ພາກທີ IV

(Part IV)

ເຄື່ອງໝາຍການຄ້າຜ່ານລະບົບມາດຣິດ

Trademarks via Madrid Protocol

5. ການດັດແກ້

(Amendments)

ພາກທີ V
(Part V)
ຖິ່ນກຳເນີດ
Geographical Indications

1. ຄຳຮ້ອງ
(Applications)

ພາກທີ V
(Part V)
ຖິ່ນກຳເນີດ
Geographical Indications

2. ຜົນການຈົດທະບຽນ
(Registration)

ພາກທີ V

(Part V)

ຖິ່ນກຳເນີດ

Geographical Indications

3. ການປ່ຽນແປງ

(Changes)

ພາກທີ V
(Part V)
ຖິ່ນກຳເນີດ
Geographical Indications

4. ການດັດແກ້
(Amendments)

ພາກທີ VI

(Part VI)

ພັນພືດໃໝ່

New Plant Varieties

1. ຄໍາຮ້ອງ

(Applications)

ພາກທີ VI

(Part VI)

ພັນພືດໃໝ່

New Plant Varieties

2. ຜົນການຈັດທະບຽນ

(Registration)

ພາກທີ VI

(Part VI)

ພັນພືດໃໝ່

New Plant Varieties

3. ການປ່ຽນແປງ

(Changes)

ພາກທີ VI

(Part VI)

ພັນພືດໃໝ່

New Plant Varieties

4. ການດັດແກ້

(Amendments)

ພາກທີ VII

(Part VII)

ລິຂະສິດ ແລະ ສິດກ່ຽວຂ້ອງກັບລິຂະສິດ

Copyrights and Related Rights

1. ການແຈ້ງຂໍ້ມູນ

(Notifications)

ພາກທີ VII

(Part VII)

ລິຂະສິດ ແລະ ສິດກ່ຽວຂ້ອງກັບລິຂະສິດ

Copyrights and Related Rights

2. ການປ່ຽນແປງ

(Changes)

ພາກທີ VIII

(Part VIII)

**ການແກ້ໄຂຂໍ້ຂັດແຍ່ງທາງດ້ານບໍລິຫານກ່ຽວກັບການຈົດທະບຽນຊັບ
ສິນອຸດສາຫະກຳ ແລະ ພັນພືດໃໝ່**

**Administrative Dispute Resolutions on the Registration of
Industrial Property and New Plant Varieties**

1. ຜົນການຄັດຄ້ານຄຳຮ້ອງ

(Result of Oppositions)

ພາກທີ VIII

(Part VIII)

**ການແກ້ໄຂຂໍ້ຂັດແຍ່ງທາງດ້ານບໍລິຫານກ່ຽວກັບການຈົດທະບຽນຊັບ
ສິນອຸດສາຫະກຳ ແລະ ພັນພືດໃໝ່**

**Administrative Dispute Resolutions on the Registration of
Industrial Property and New Plant Varieties**

2. ຜົນການແຈ້ງປະຕິເສດ

(Result of Refusals)

ພາກທີ VIII

(Part VIII)

**ການແກ້ໄຂຂໍ້ຂັດແຍ່ງທາງດ້ານບໍລິຫານກ່ຽວກັບການຈັດທະບຽນຊັບ
ສິນອຸດສາຫະກຳ ແລະ ພັນພືດໃໝ່**

**Administrative Dispute Resolutions on the Registration of
Industrial Property and New Plant Varieties**

**3. ຜົນການຍົກເລີກ ຫຼື ລົບລ້າງ ຂອງການຈັດທະບຽນ
(Result of Cancellation or Invalidation of Registration)**