



ສາທາລະນະລັດ ປະຊາທິປະໄຕ ປະຊາຊົນລາວ
LAO PEOPLE'S DEMOCRATIC REPUBLIC

ກະຊວງ ອຸດສາຫະກຳ ແລະ ການຄ້າ
ກົມຊັບສິນທາງປັນຍາ

MINISTRY OF INDUSTRY AND COMMERCE
DEPARTMENT OF INTELLECTUAL PROPERTY

ຈົດໝາຍເຫດທາງລັດຖະການ
ກ່ຽວກັບ ຊັບສິນທາງປັນຍາ
ຢູ່ ສປປ ລາວ

OFFICIAL GAZETTE ON INTELLECTUAL PROPERTY
IN LAO PDR

ສະບັບທີ (Vol.) 172

ພາກທີ I

(Part I)

ສິດທິບັດ ແລະ ອະນຸສິດທິບັດ (Patent and Petty Patent)

1. ຄໍາຮ້ອງ

(Applications)

ຄໍາອະທິບາຍກ່ຽວກັບລະຫັດຫຍໍ້

(Introduction of Codes)

- (21) ເລກທີ ຄໍາຮ້ອງ (Filing Number)
- (22) ວັນທີ ຍືນຄໍາຮ້ອງ (Filing Date)
- (30) ວັນທີ ບຸລິມະສິດ (Priority Date)
- (43) ວັນທີເຜີຍແຜ່ (Publication Date)
- (51) ໝວດ (International Patent Classification)
- (54) ຊື່ຂອງການປະດິດ (Title)
- (57) ບົດຄັດຫຍໍ້ (Abstract)
- (71) ຊື່ ແລະ ທີ່ຢູ່ ເຈົ້າຂອງສິດທິບັດ ແລະ ອະນຸສິດທິບັດ (Owner Name and Address)
- (72) ຊື່ຜູ້ປະດິດ (Inventor Name)
- (74) ຊື່ຕົວແທນ (Representative Name)
- (55) ຮູບພາບ (Pictures)

ພາກທີ I (Part I)

ສິດທິບັດ ແລະ ອະນຸສິດທິບັດ (Patent and Petty Patent)

2. ຜົນການອອກສິດທິບັດ ແລະ ອະນຸສິດທິບັດ (Grant of Patents and Petty Patents)

ຄຳອະທິບາຍກ່ຽວກັບລະຫັດຫຍໍ້ (Introduction of Codes)

- (11) ເລກທິ (Grant Number)
- (21) ເລກທິ ຄຳຮ້ອງ (Filing Number)
- (22) ວັນທີຍືນຄຳຮ້ອງ (Filing Date)
- (30) ວັນທີ ບຸລິມະສິດ (Priority Date)
- (43) ວັນທີເຜີຍແຜ່ (Publication Date)
- (51) ໝວດ (International Patent Classification)
- (54) ຫົວຂໍ້ການປະດິດ (Title)
- (57) ບົດຄັດຫຍໍ້ (Abstract)
- (71) ຊື່ ແລະ ທີ່ຢູ່ ເຈົ້າຂອງສິດທິບັດ ແລະ ອະນຸສິດທິບັດ (Owner Name and Address)
- (72) ຊື່ຜູ້ປະດິດ (Inventor Name)
- (74) ຊື່ຕົວແທນ (Representative Name)
- (55) ຮູບພາບ (Pictures)

- (11) No. 685
- (21) PA 685
- (22) 25/10/2019
- (30) 2017-087104 26/04/2017 JP
- (43)
- (51) Int.Cl.H 02J 13/00(2006.01)
- (54) MONITORING CONTROL SYSTEM
- (57) Provided is a monitoring control system with which it is possible to make data linkage between systems more efficient. The monitoring control system is provided with at least one system-monitoring control sub-system for controlling the monitoring of a power transmission system, at least one distribution-monitoring control sub-system for controlling the monitoring of a power distribution system, a computation server for storing shutdown plan names relating to the shutdown of the power transmission system and the shutdown of the power distribution system, and a network for connecting the system-monitoring control sub-system, the distribution-monitoring control sub-system, and the computation server. Monitoring of the power transmission system and the power distribution system is controlled on the basis of the shutdown plan name.
- (71) TOSHIBA ENERGY SYSTEMS & SOLUTIONS CORPORATION
72-34, Horikawa-cho, Saiwai-ku, Kawasaki-shi, Kanagawa 2120013, Japan, Japan
TOKYO ELECTRIC POWER COMPANY HOLDING, INCORPORATED
1-3, Uchisaiwai-cho 1-chome, Chiyoda-ku, Tokyo 1008560, Japan, Japan.
- (72) FUJIURA, Hiroaki; ONISHI, Masami; FUJII, Hirofumi; SATO, Hiroaki; TAKEUCHI, Koichi;; YAMAMOTO, Junya; EGUCHI, Takashi; KUBO, Tomohiro; ENDO, Masanori; KITAMI, Kenji;; HOSAKA, Takaaki and INOUE, Jun.
- (74) Tilleke & Gibbins International Ltd.
- (55)

図1]

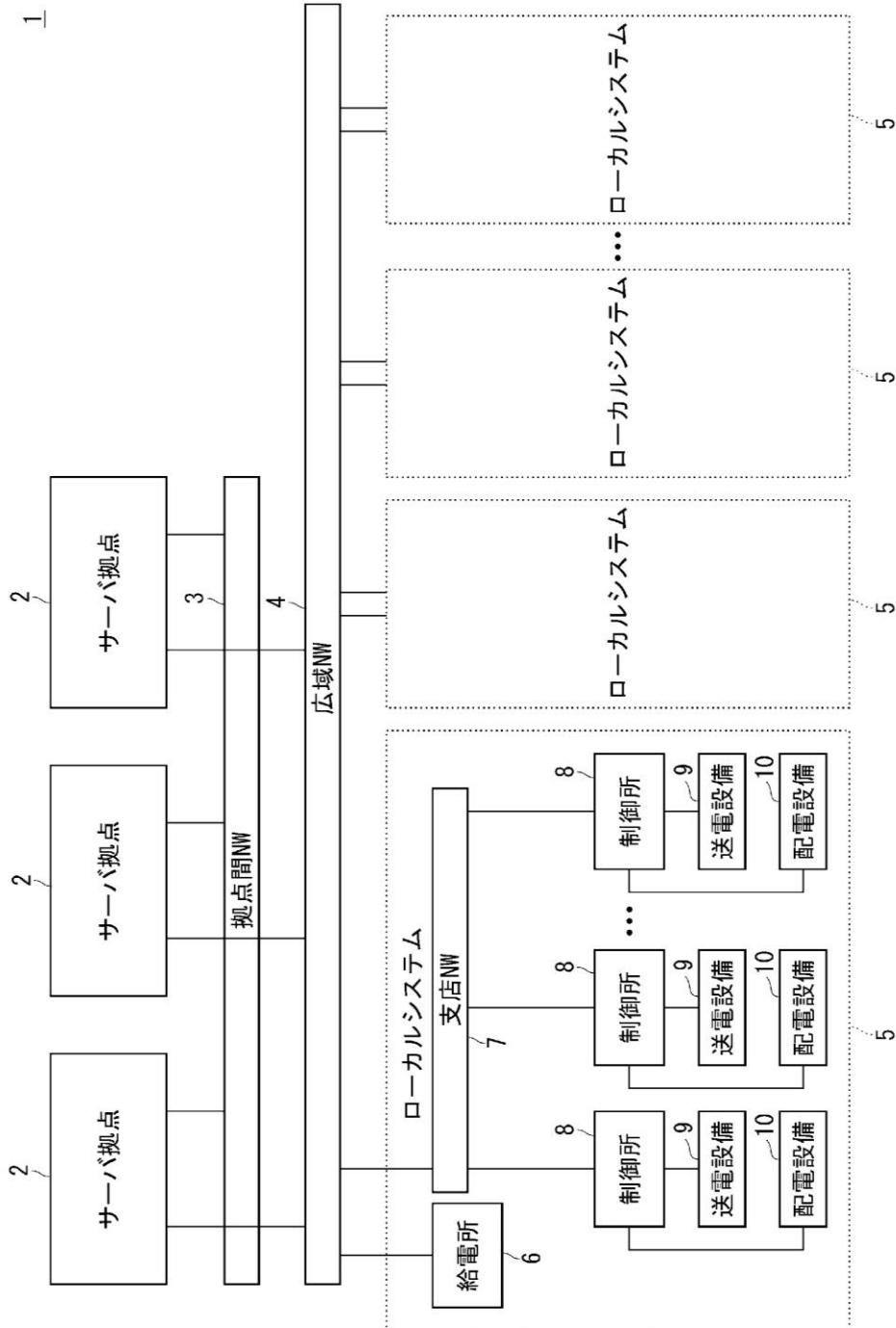

[図2]

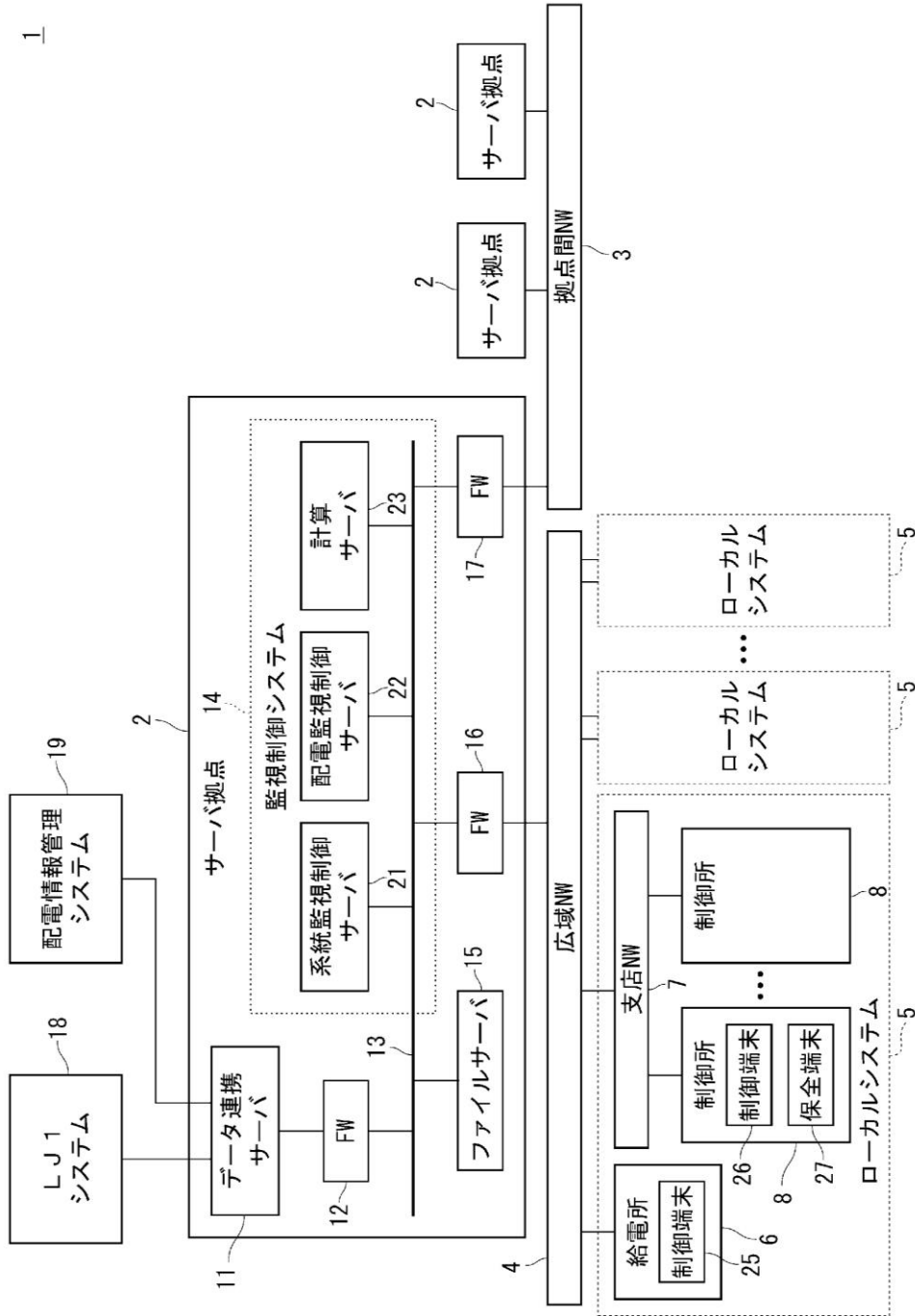

1

[図3]

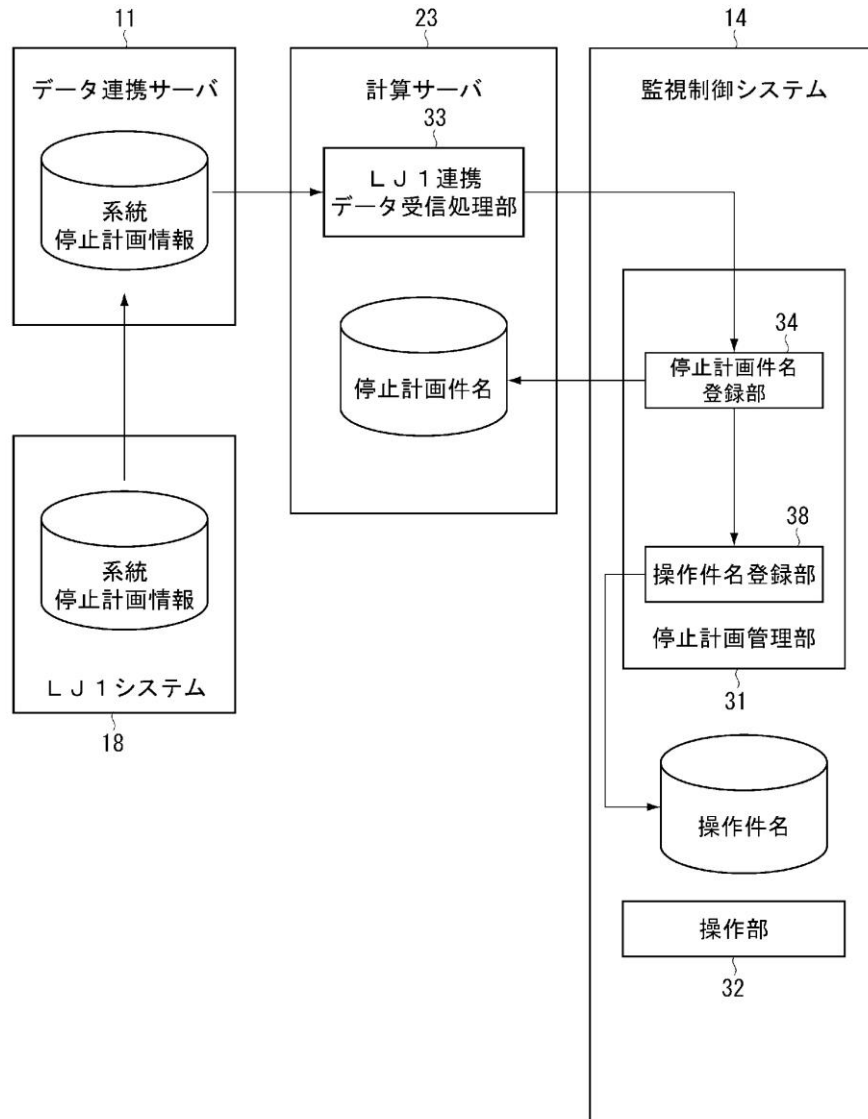

[図4]

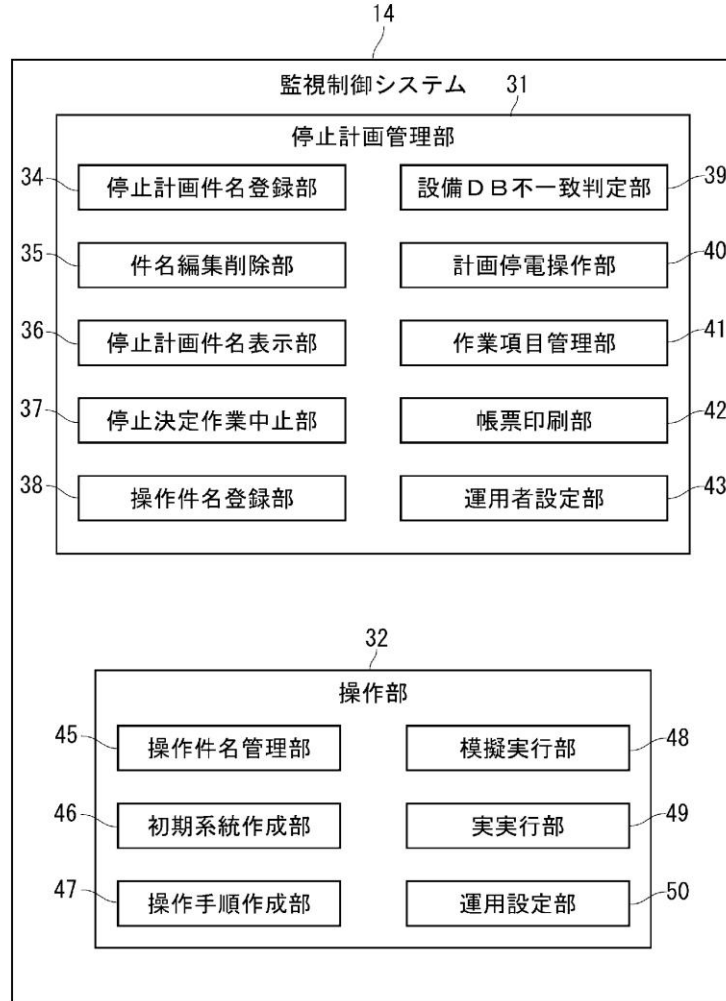

[図5]

計画No.	停止計画件名	停止計画情報	
		事業所	設備名
1	1号変圧器停止計画	地域A	変電所A 変圧器No. 1
2	母線停止計画	地域A	変電所A 母線No. 1
3	配電線区間1停止計画	地域A	配電線No. 1 区間No. 1
⋮	⋮	⋮	⋮

[図6]

操作No.	操作件名	計画No.	操作手順
1	操作件名A	1	SH
2	操作件名C	3	TH
⋮	⋮	⋮	⋮

[図7]

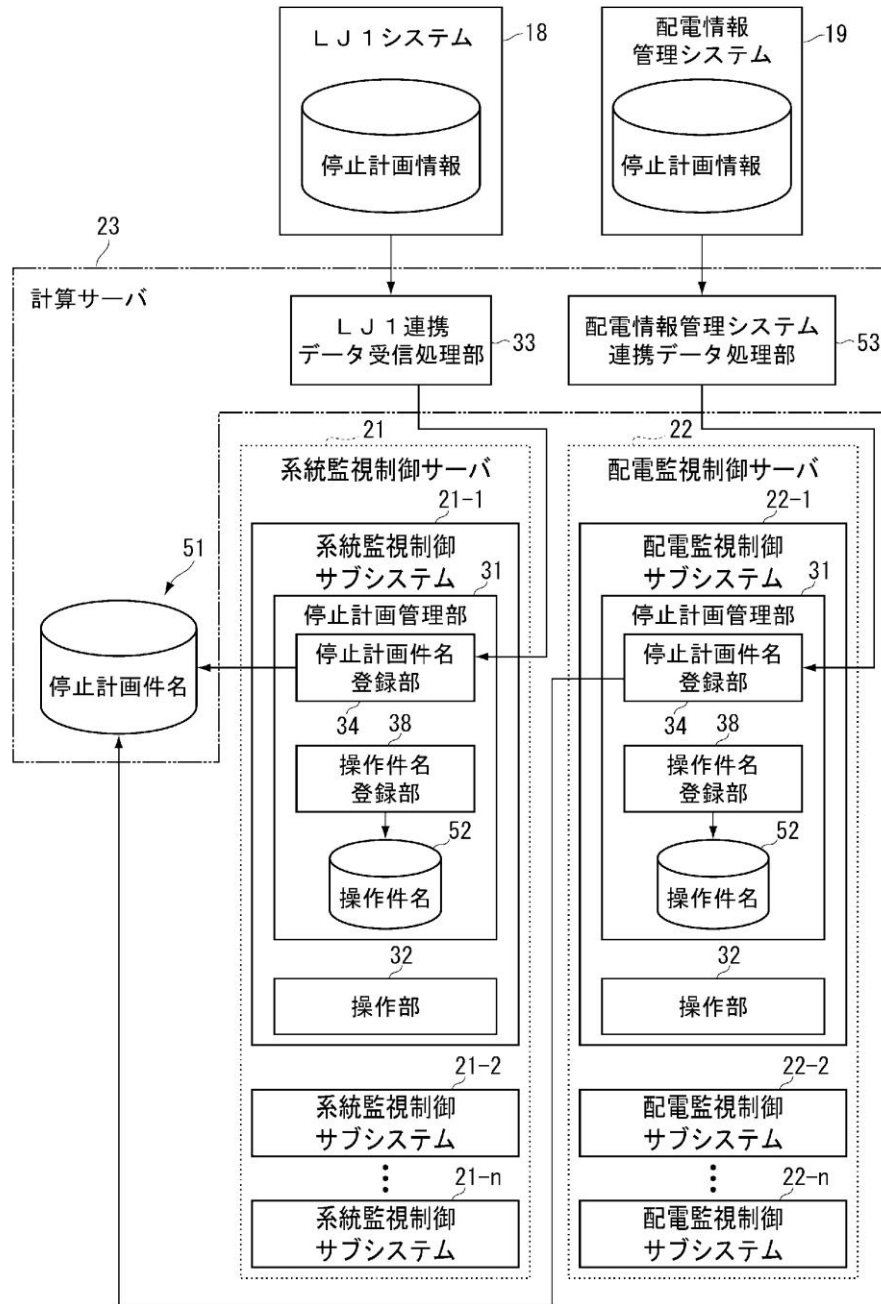

[図8]

1

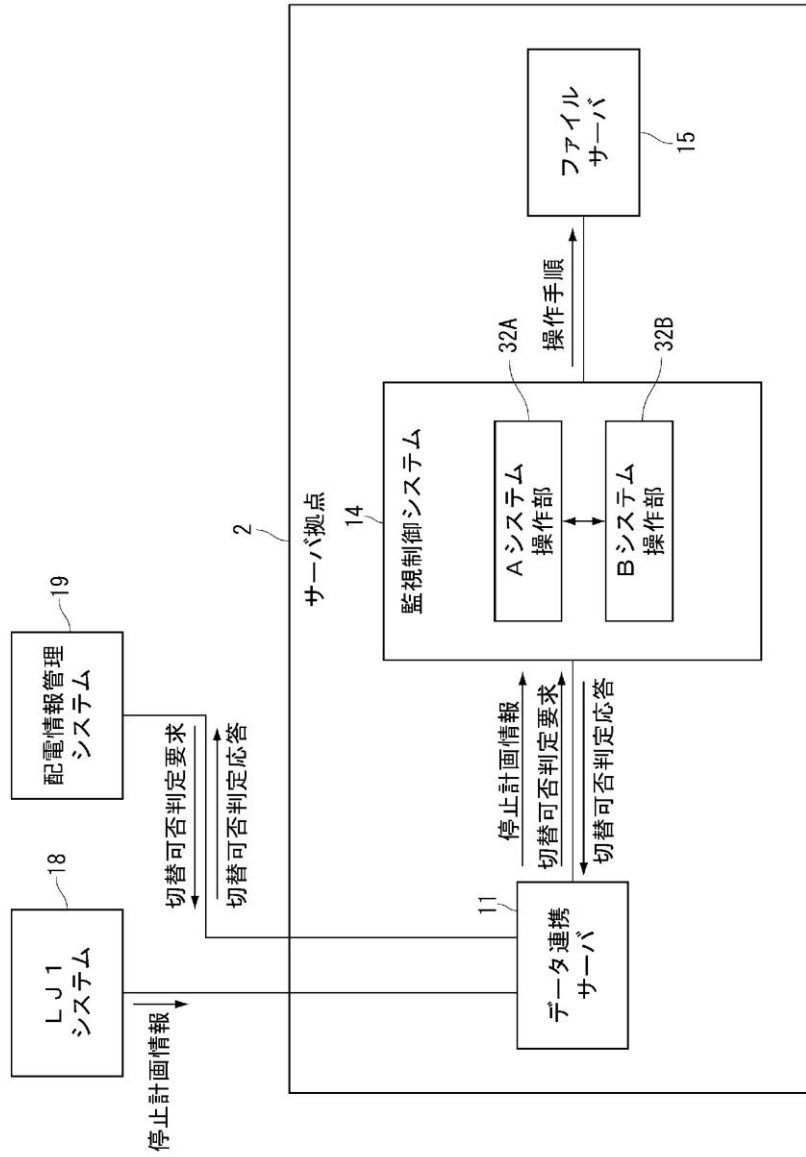

[図9]

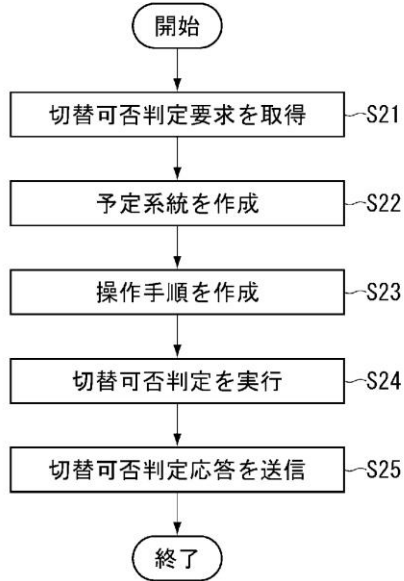

[図10]

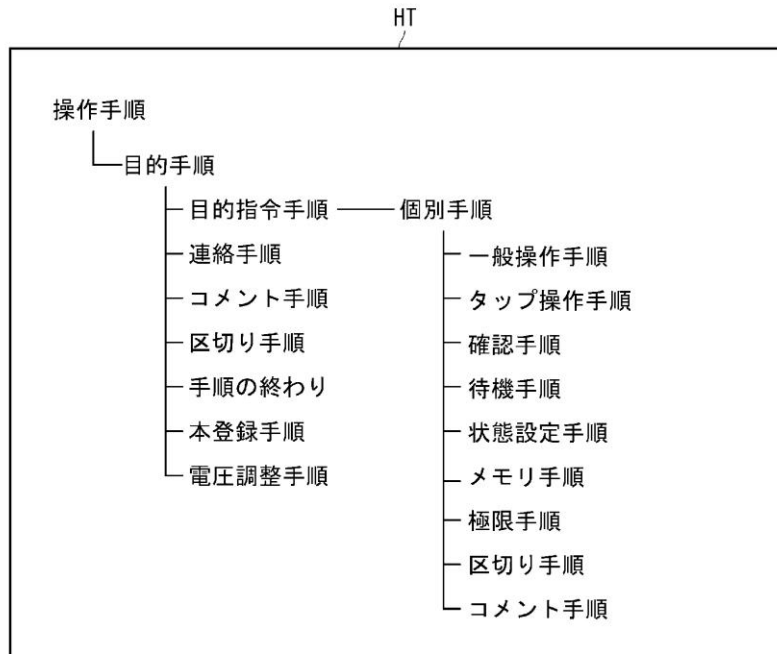

[図11]

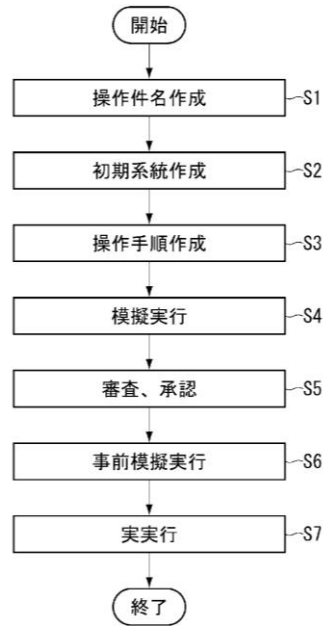

[図12]



[図13]

(A)

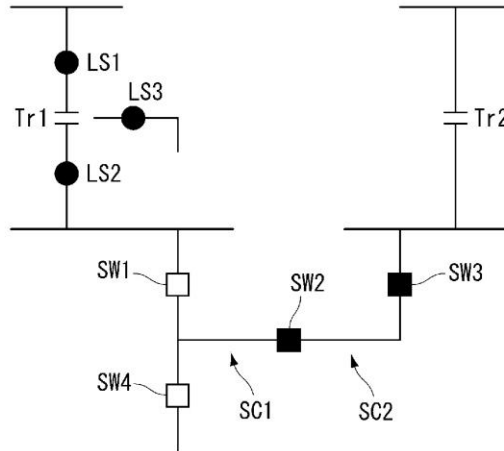

(B)

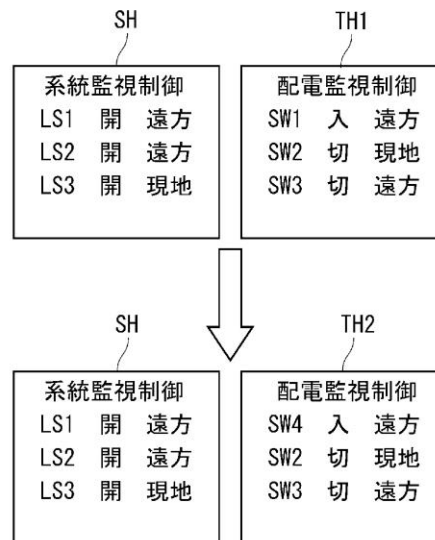

[図14]

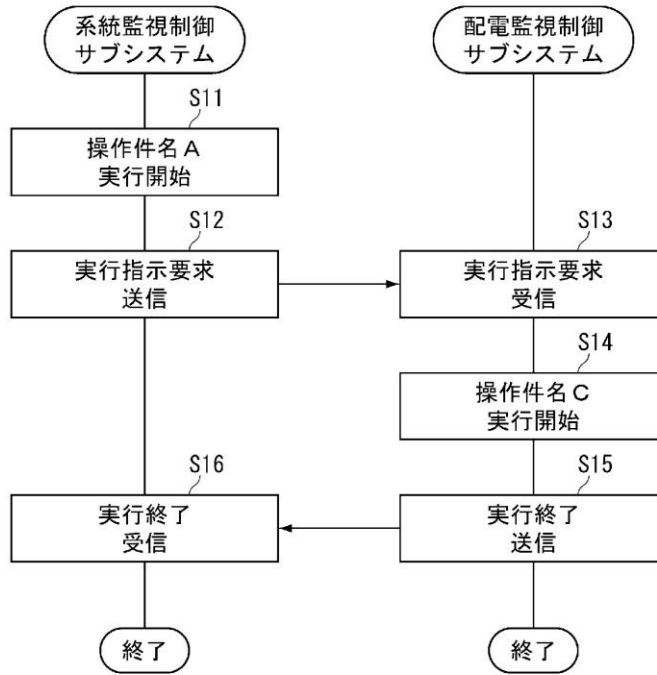

- (11) No. 686
- (21) PA 686
- (22) 25/10/2019
- (30) 2017-087105 26/04/2017 JP
- (43)
- (51) Int.Cl.H 02J 13/00(2006.01)
- (54) MONITORING CONTROL SYSTEM
- (57) .
- (71) TOSHIBA ENERGY SYSTEMS & SOLUTIONS CORPORATION
72-34, Horikawa-cho, Saiwai-ku, Kawasaki-shi, Kanagawa 2120013, Japan.
- (72) FUJIURA, Hiroaki; ONISHI, Masami; FUJII, Hirofumi; SATO, Hiroaki; YAMAMOTO, Junya; EGUCHI, Takashi; KUBO, Tomohiro; ENDO, Masanori; HOSAKA, Takaaki; INOUE, Jun; TAKEUCHI, Koichi and KITAMI, Kenji.
- (74) Tilleke & Gibbins International Ltd.
- (55)

【図1】

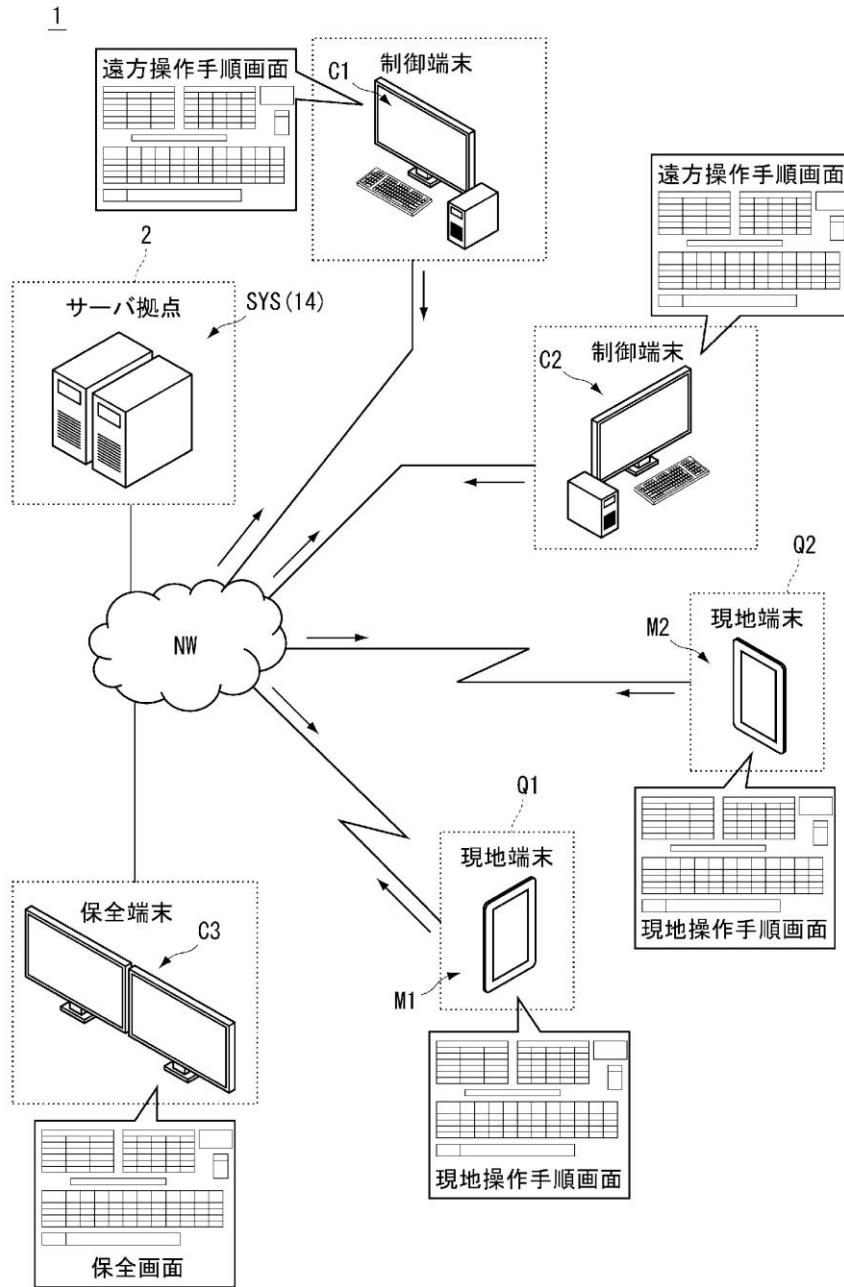

【図2】

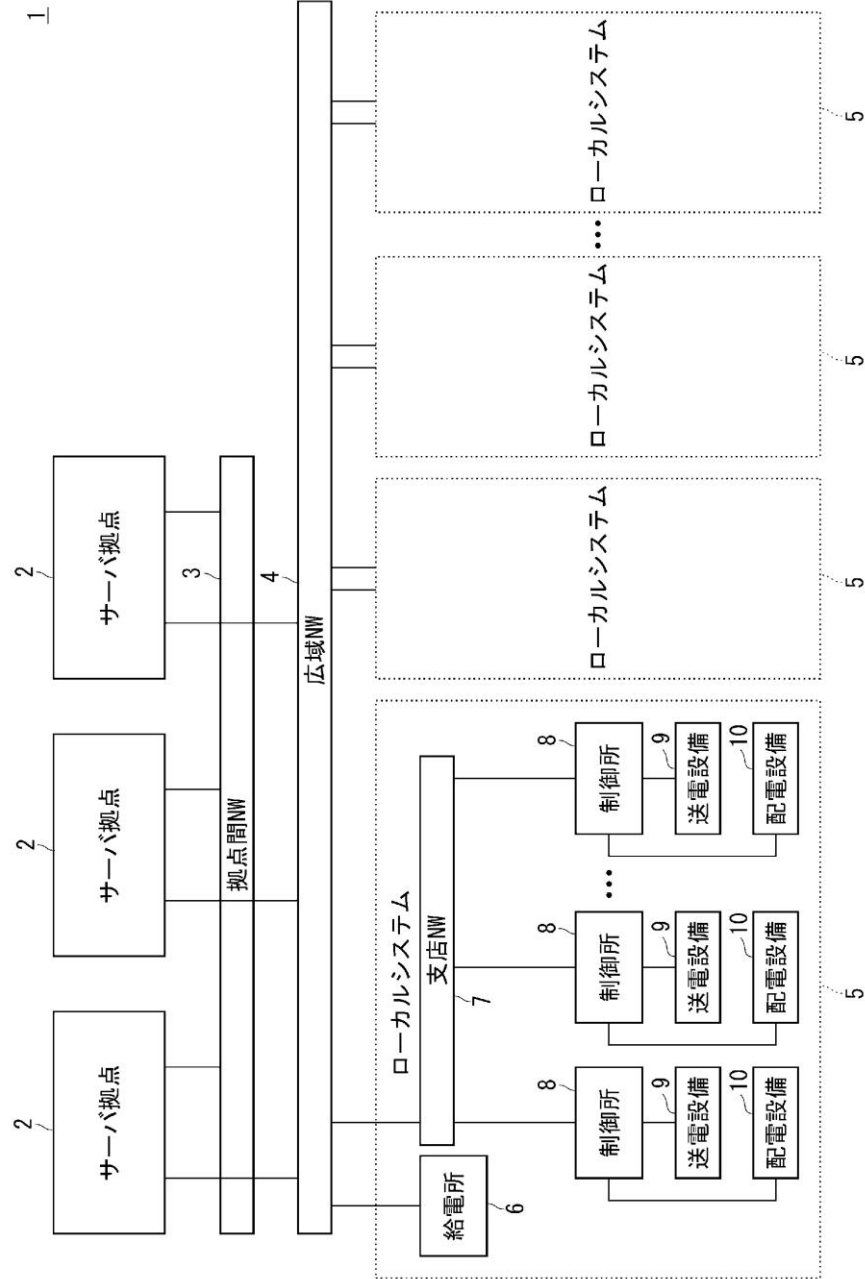

[図3]

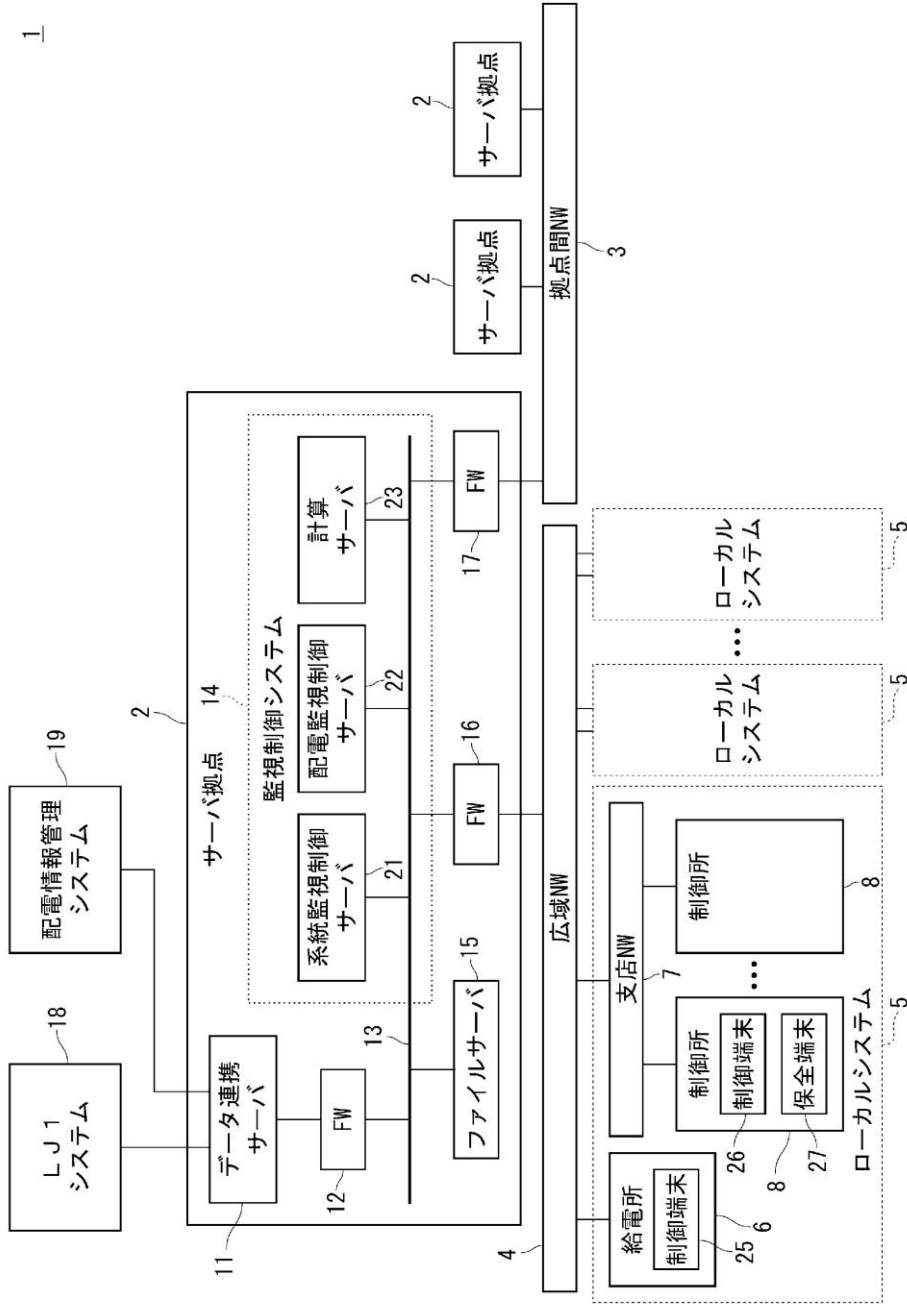

1

[図4]

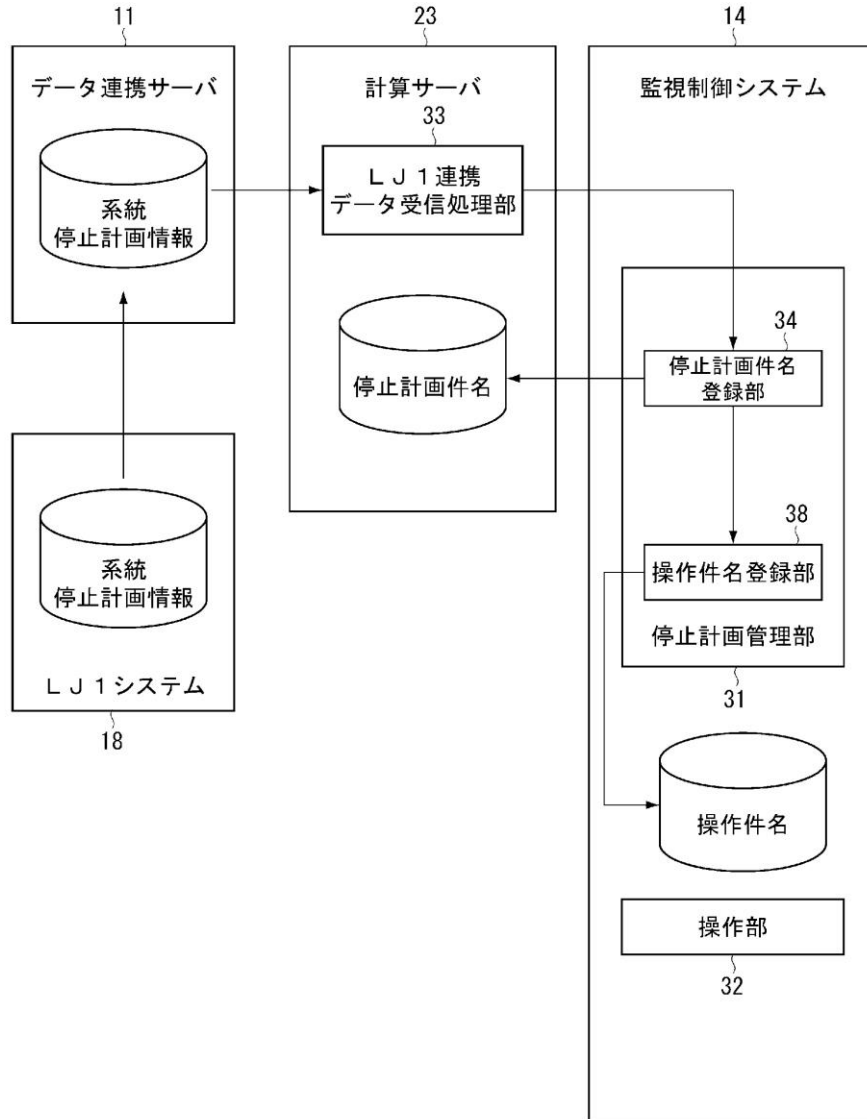

[図5]

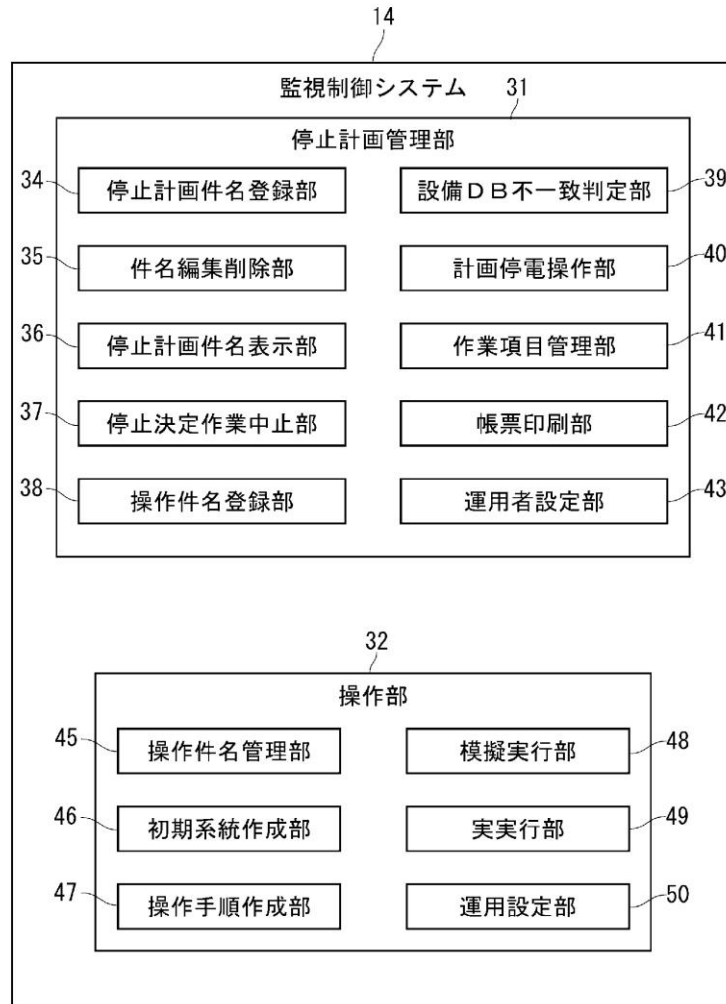

[図6]

計画No.	停止計画件名	停止計画情報	
		事業所	設備名
1	1号変圧器停止計画	地域A	変電所A 変圧器No. 1
2	母線停止計画	地域A	変電所A 母線No. 1
3	配電線区間1停止計画	地域A	配電線No. 1 区間No. 1
⋮	⋮	⋮	⋮

[図7]

操作No.	操作件名	計画No.	操作手順
1	操作件名A	1	SH
2	操作件名C	3	TH
⋮	⋮	⋮	⋮

[図8]

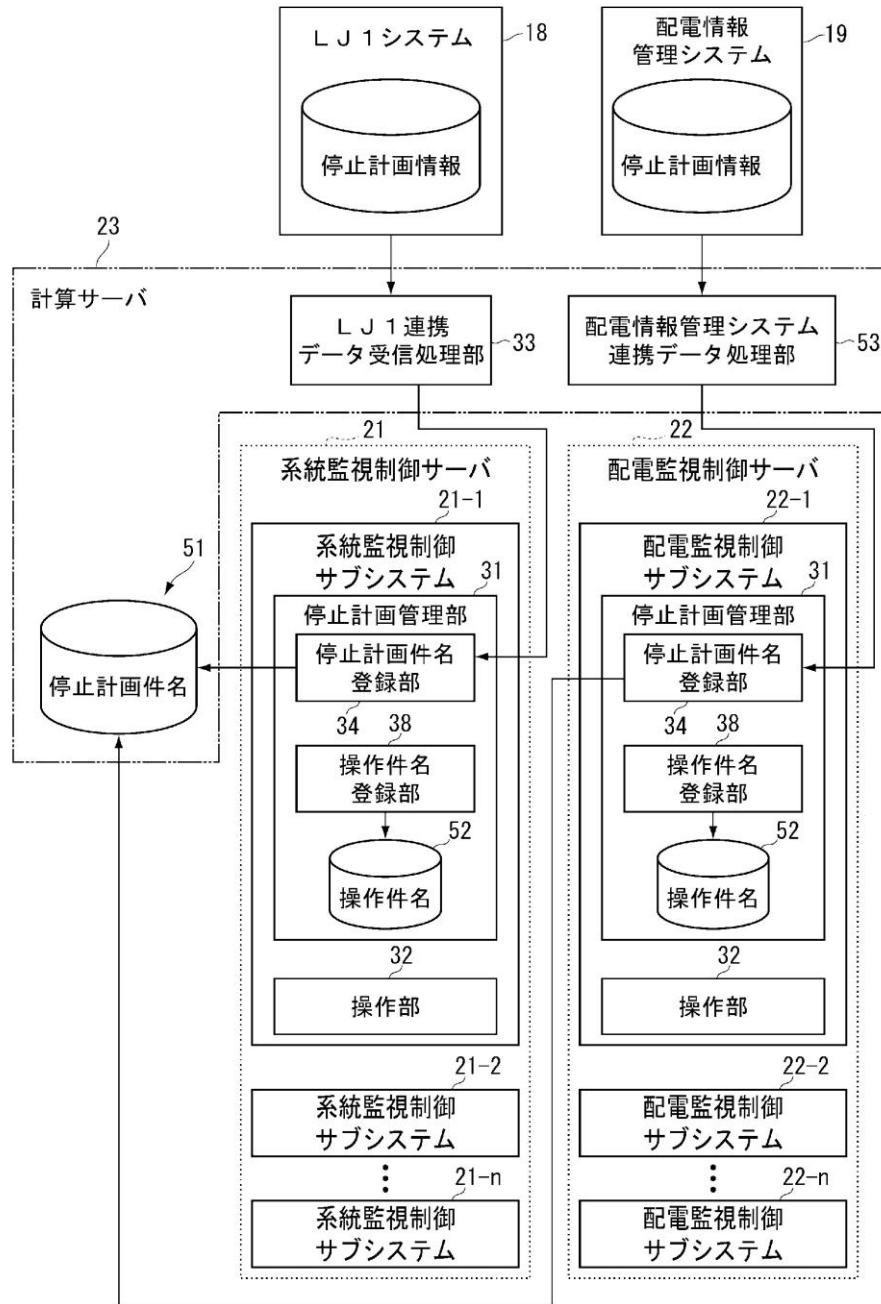

[図9]

1

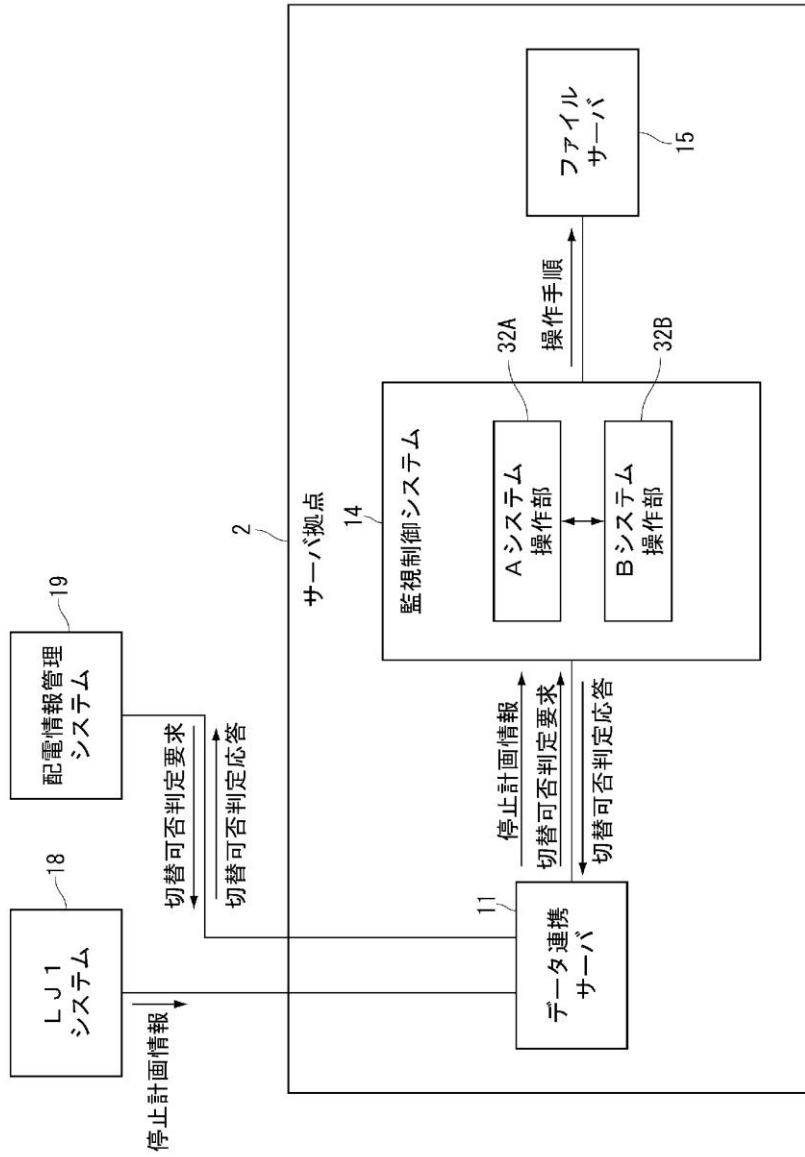

[図10]

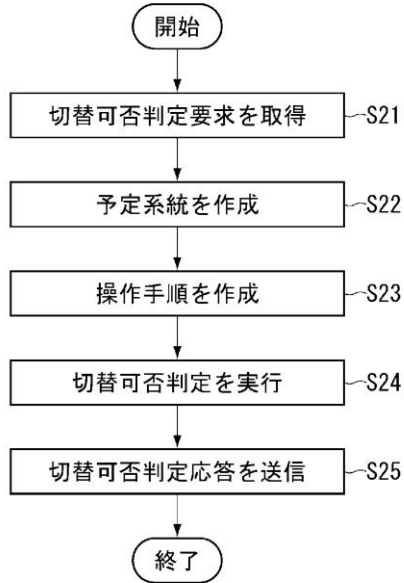

[図11]

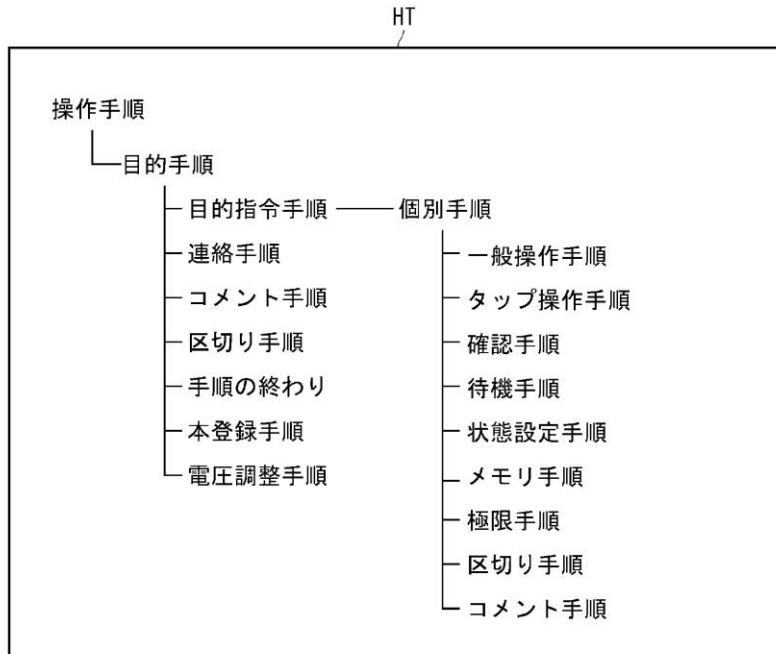

[図12]

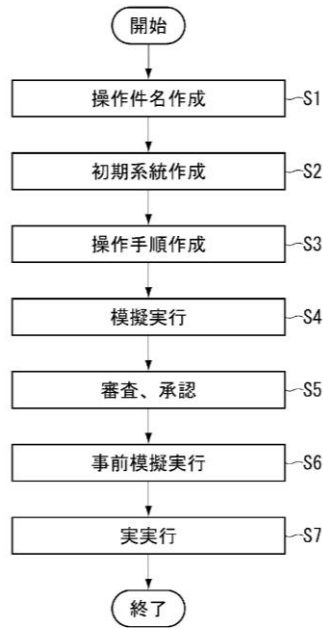

[図13]

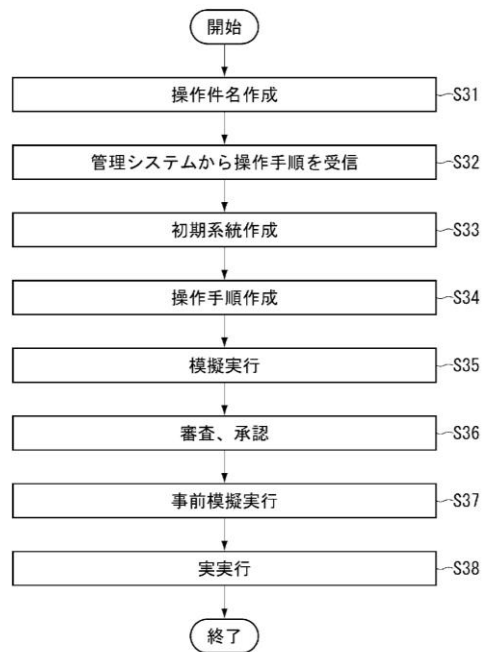

[図14]

(A)

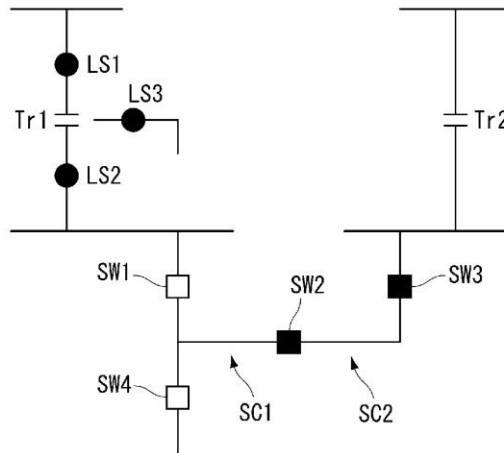

(B)

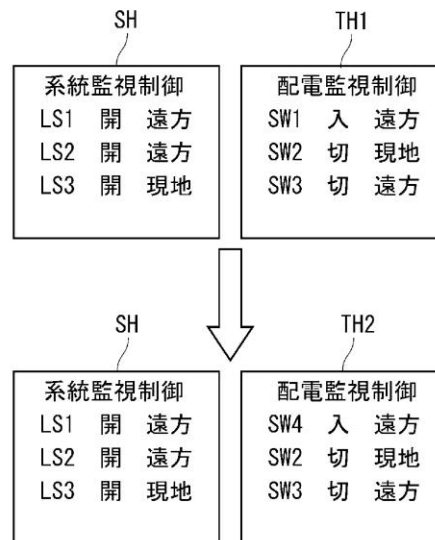

[図15]

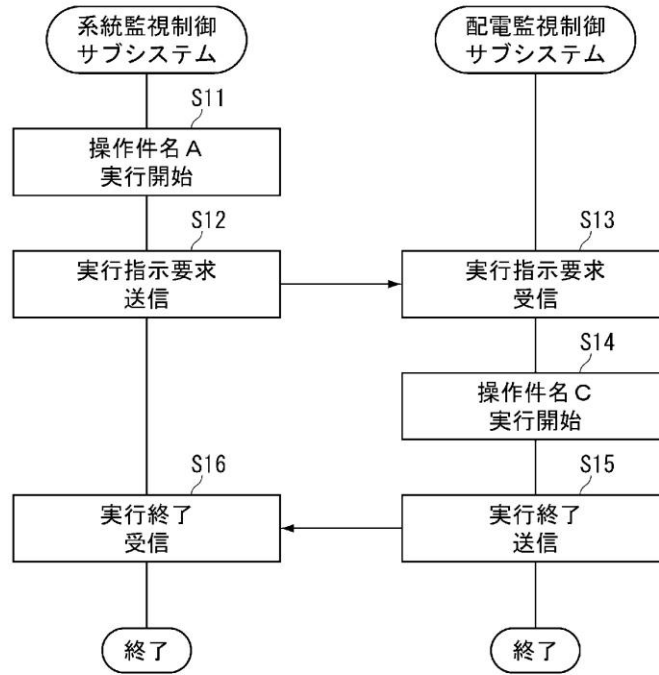

[図16]

(A)

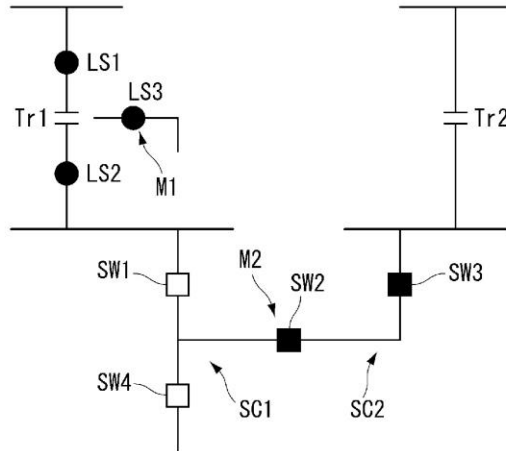

(B)

番号	対象設備	操作内容	遠方現地区分	通信対象
1	LS1	開	遠方	設備
2	LS2	開	遠方	設備
3	LS3	開	現地	現地端末M1
4	SW4	入	遠方	設備
5	SW2	切	現地	現地端末M2
6	SW3	切	遠方	設備

[図17]

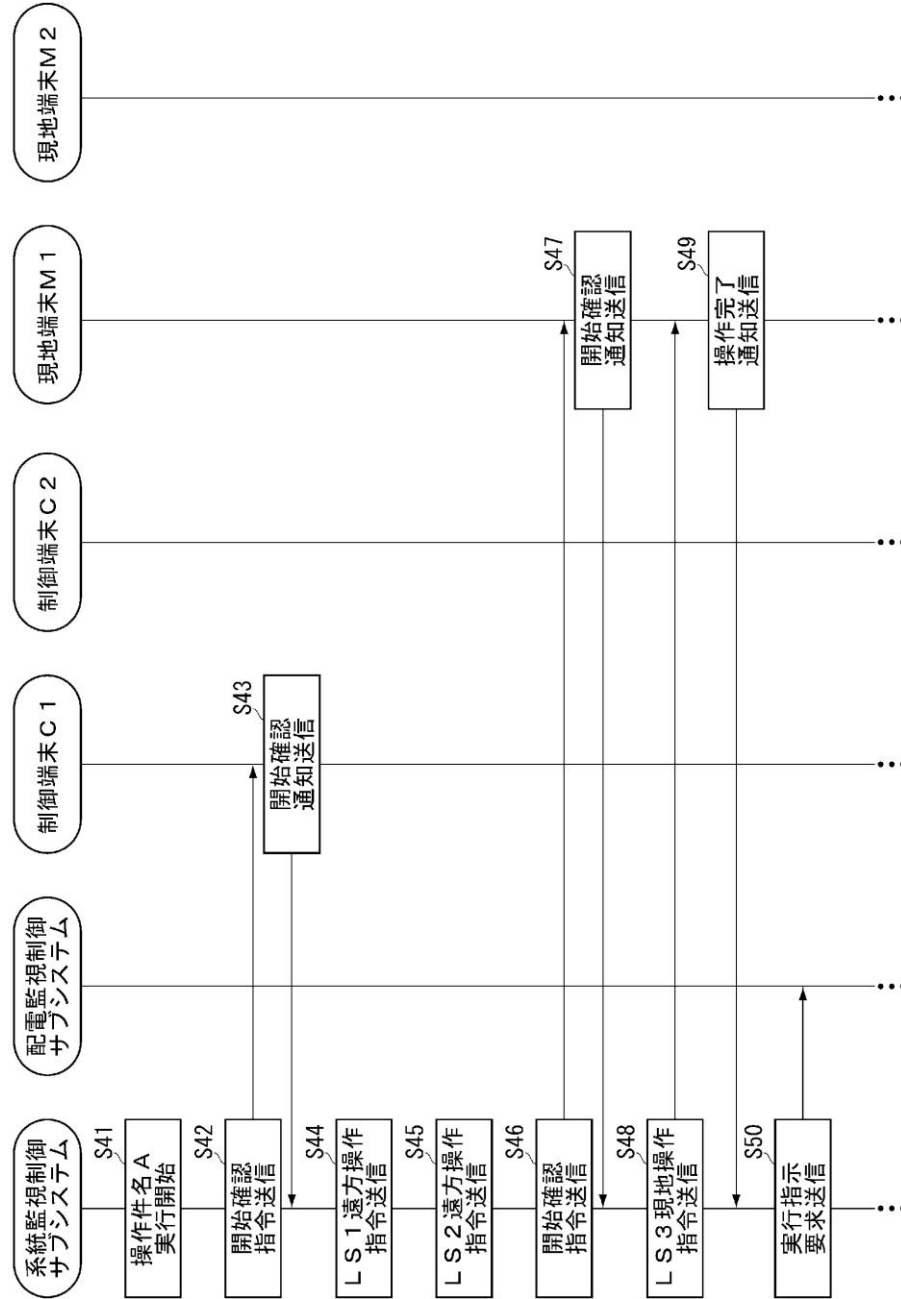

[図18]

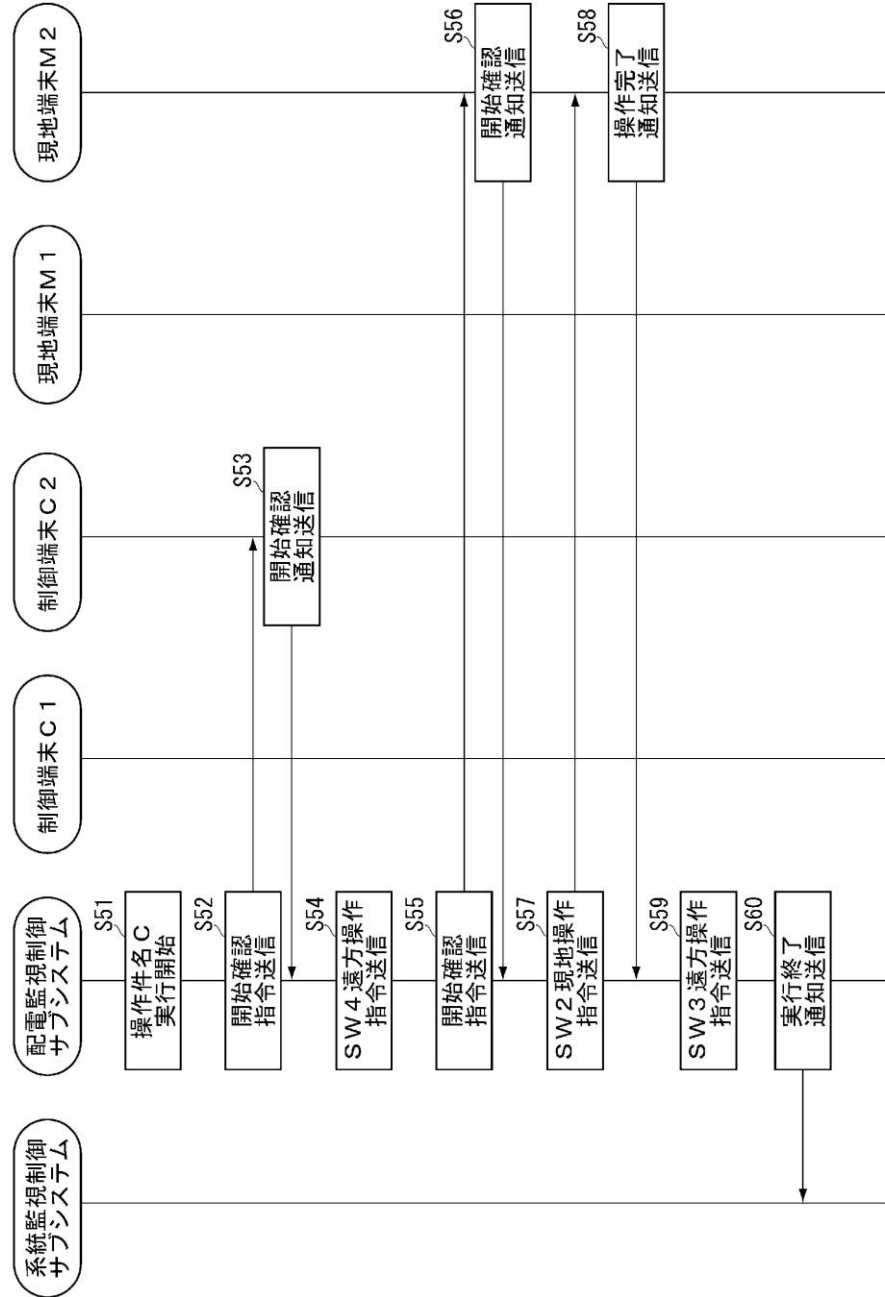

ພາກທີ I

(Part I)

**ສິດທິບັດ ແລະ ອະນຸສິດທິບັດ
(Patent and Petty Patent)**

3. ການປ່ຽນແປງ

(Changes)

ພາກທີ I

(Part I)

**ສິດທິບັດ ແລະ ອະນຸສິດທິບັດ
(Patent and Petty Patent)**

4. ການດັດແກ້

(Amendments)

ພາກທີ II
(Part II)
ແບບອຸດສາຫະກຳ
(Industrial Design)

1. ຄຳຮ້ອງ
(Applications)

ຄຳອະທິບາຍກ່ຽວກັບລະຫັດຫຍໍ້
(Introduction of Codes)

- (21) ເລກທີ ຄຳຮ້ອງ (Filing Number)
- (22) ວັນທີ ຄຳຮ້ອງ (Filing Date)
- (30) ວັນທີ ບຸລິມາສິດ (Priority Date)
- (51) ໝວດ (Locarno Classification)
- (54) ຊື່ຂອງແບບອຸດສາຫະກຳ (Title)
- (71) ຊື່ ແລະ ທີ່ຢູ່ ຂອງເຈົ້າຂອງ (Owner Name and Address)
- (72) ຊື່ຜູ້ອອກແບບ (Designer Name)
- (74) ຊື່ຕົວແທນ (Representative Name)
- (55) ຮູບພາບ (Pictures)

ພາກທີ II
(Part II)
ແບບອຸດສາຫະກຳ
(Industrial Design)

2. ຜົນການຈົດທະບຽນ
(Registration)

ຄຳອະທິບາຍກ່ຽວກັບລະຫັດຫຍໍ້
(Introduction of Codes)

- (11) ເລກທີ ຈົດທະບຽນ (Registration Number)
- (15) ວັນທີ ຈົດທະບຽນ (Registration Date)
- (21) ເລກທີ ຍືນຄຳຮ້ອງ (Filing Number)
- (22) ວັນທີ ຍືນຄຳຮ້ອງ (Filing Date)
- (30) ວັນທີ ບຸລິມາສິດ (Priority Date)
- (17) ວັນທີ ໝົດອາຍຸ (Expiration Date)
- (51) ໝວດ (Locarno Classification)
- (54) ຊື່ຂອງແບບອຸດສາຫະກຳ (Title)
- (71) ຊື່ ແລະ ທີ່ຢູ່ ຂອງເຈົ້າຂອງ (Owner Name and Address)
- (72) ຊື່ຜູ້ອອກແບບ (Designer Name)
- (74) ຊື່ຕົວແທນ (Representative Name)
- (55) ຮູບພາບ (Pictures)

ພາກທີ II

(Part II)

ແບບອຸດສາຫະກຳ

(Industrial Design)

3. ການປ່ຽນແປງ

(Changes)

ພາກທີ II

(Part II)

ແບບອຸດສາຫະກຳ

(Industrial Design)

4. ການດັດແກ້

(Amendments)

ພາກທີ III
(Part III)
ເຄື່ອງໝາຍການຄ້າ
Trademarks

1. ຄໍາຮ້ອງ
(Applications)

ຄໍາອະທິບາຍກ່ຽວກັບລະຫັດຫຍໍ້
(Introduction of Codes)

- (540) ເຄື່ອງໝາຍການຄ້າ (Trademark)
- (511) ໝວດ (Nice Classification)
- (210) ເລກທີ ຄໍາຮ້ອງ (Number of the application)
- (220) ວັນທີ ຄໍາຮ້ອງ (Date of filing of the application)
- (732) ຊື່ ແລະ ທີ່ຢູ່ ຂອງຜູ້ຍື່ນຄໍາຮ້ອງ (Name and Address of applicant)

ພາກທີ III

(Part III)

ເຄື່ອງໝາຍການຄ້າ

Trademarks

2. ຜົນການຈົດທະບຽນ

(Registration)

ຄຳອະທິບາຍກ່ຽວກັບລະຫັດຫຍໍ້

(Introduction of Codes)

- (540) ເຄື່ອງໝາຍການຄ້າ (Trademark)
- (511) ໝວດ (Nice Classification)
- (210) ເລກທີ ຄຳຮ້ອງ (Number of the application)
- (220) ວັນທີ ຄຳຮ້ອງ (Date of filing of the application)
- (732) ຊື່ ແລະ ທີ່ຢູ່ ຂອງຜູ້ຍື່ນຄຳຮ້ອງ (Name and Address of applicant)
- (111) ເລກທີ ການຈົດທະບຽນເຄື່ອງໝາຍການຄ້າ (Number of the registration)
- (180) ວັນໝົດອາຍຸຂອງການຈົດທະບຽນ (Expiration date of the registration)

ພາກທີ III
(Part III)
ເຄື່ອງໝາຍການຄ້າ
Trademarks

3. ການຕໍ່ອາຍຸ
(Renewal)

ຄຳອະທິບາຍກ່ຽວກັບລະຫັດຫຍໍ້
(Introduction of Codes)

- (540) ເຄື່ອງໝາຍການຄ້າ (Trademark)
- (511) ໝວດ (Nice Classification)
- (210) ເລກທີ ຄຳຮ້ອງ (Number of the application)
- (220) ວັນທີ ຄຳຮ້ອງ (Date of filing of the application)
- (732) ຊື່ ແລະ ທີ່ຢູ່ ຂອງຜູ້ຍື່ນຄຳຮ້ອງ (Name and Address of applicant)
- (111) ເລກທີການຈັດທະບຽນເຄື່ອງໝາຍການຄ້າ (Number of the registration)
- (180) ການຕໍ່ອາຍຸການຈັດທະບຽນ (Expiration date of the renewal)

(540) Renewal

SUZUKI

(511) 04, 07 and 12

(210) No. 877

(220) 25/05/1992

(732) Suzuki Motor Corporation

300 Takatsuka-cho, Minami-ku Hamamatsu-
shi, Shizuoka-ken, Japan

(111) No. 850

(180) 25/05/2042

(540) Renewal

SUZUKI

(511) 04, 07 and 12

(210) No. 877

(220) 25/05/1992

(732) Suzuki Motor Corporation

300 Takatsuka-cho, Minami-ku Hamamatsu-
shi, Shizuoka-ken, Japan

(111) No. 850

(180) 25/05/2052

(540) Renewal

SUZUKI

(511) 04, 07 and 12

(210) No. 877

(220) 25/05/1992

(732) Suzuki Motor Corporation

300 Takatsuka-cho, Minami-ku Hamamatsu-
shi, Shizuoka-ken, Japan

(111) No. 850

(180) 25/05/2032

(540) Renewal

SWIFT

(511) 12

(210) No. 878

(220) 25/05/1992

(732) Suzuki Motor Corporation

300 Takatsuka-cho, Minami-ku Hamamatsu-
shi, Shizuoka-ken, Japan

(111) No. 851

(180) 25/05/2032

(540) Renewal

VITARA

(511) 12

(210) No. 880

(220) 25/05/1992

(732) Suzuki Motor Corporation

300 Takatsuka-cho, Minami-ku Hamamatsu-
shi, Shizuoka-ken, Japan

(111) No. 853

(180) 25/05/2032

(540) Renewal

CARRY

(511) 12

(210) No. 881

(220) 25/05/1992

(732) Suzuki Motor Corporation

300 Takatsuka-cho, Minami-ku Hamamatsu-
shi, Shizuoka-ken, Japan

(111) No. 854

(180) 25/05/2032

(540) Renewal



(511) 12

(210) No. 885

(220) 25/05/1992

(732) Suzuki Motor Corporation

300 Takatsuka-cho, Minami-ku Hamamatsu-
shi, Shizuoka-ken, Japan

(111) No. 858

(180) 25/05/2032

(540) Renewal

SUCHARD

(511) 30

(210) No. 889

(220) 25/05/1992

(732) Kraft Foods Schweiz Holding GmbH

Chollerstrasse 4, 6300 Zug, Switzerland

(111) No. 862

(180) 25/05/2032

(540) Renewal

TOBLERONE

(511) 30

(210) No. 890

(220) 25/05/1992

(732) Kraft Foods Schweiz Holding GmbH

Chollerstrasse 4, 6300 Zug, Switzerland

(111) No. 863

(180) 25/05/2032

(540) Renewal

MILKA

(511) 30

(210) No. 892

(220) 25/05/1992

(732) Kraft Foods Schweiz Holding GmbH

Chollerstrasse 4, 6300 Zug, Switzerland

(111) No. 865

(180) 25/05/2032

(540) Renewal

PACO RABANNE

(511) 03

(210) No. 1245

(220) 20/08/1992

(732) PUIG FRANCE

65/67 avenue des Champs-Élysées, 75008

Paris, France

(111) No. 1200

(180) 20/08/2032

(540) Renewal

ALFFI

(511) 29

(210) No. 9387

(220) 29/05/2002

(732) Kuok Oils & Grains Pte Ltd.

No.1 Kim Seng Promenade, #05-01 Great

World City, 237994, Singapore

(111) No. 8916

(180) 29/05/2032

(540) Renewal

ALFFI

(511) 03

(210) No. 9388

(220) 29/05/2002

(732) Kuok Oils & Grains Pte Ltd.

No.1 Kim Seng Promenade, #05-01 Great
World City, 237994, Singapore

(111) No. 8917

(180) 14/09/2042

(540) Renewal

ALFFI

(511) 31

(210) No. 9389

(220) 29/05/2002

(732) Kuok Oils & Grains Pte Ltd.

No.1 Kim Seng Promenade, #05-01 Great
World City, 237994, Singapore

(111) No. 8918

(180) 14/09/2042

(540) Renewal

KORIE

(511) 29

(210) No. 9390

(220) 29/05/2002

(732) Kuok Oils & Grains Pte Ltd.

No.1 Kim Seng Promenade, #05-01 Great
World City, 237994, Singapore

(111) No. 8919

(180) 14/09/2042

(540) Renewal

KORIE

(511) 30

(210) No. 9391

(220) 29/05/2002

(732) Kuok Oils & Grains Pte Ltd.

No.1 Kim Seng Promenade, #05-01 Great
World City, 237994, Singapore

(111) No. 8920

(180) 14/09/2042

(540) Renewal

KORIE

(511) 31

(210) No. 9392

(220) 29/05/2002

(732) Kuok Oils & Grains Pte Ltd.

No.1 Kim Seng Promenade, #05-01 Great
World City, 237994, Singapore

(111) No. 8921

(180) 14/09/2042

(540) Renewal

KING'S

(511) 29

(210) No. 9393

(220) 29/05/2002

(732) Kuok Oils & Grains Pte Ltd.

No.1 Kim Seng Promenade, #05-01 Great
World City, 237994, Singapore

(111) No. 8922

(180) 14/09/2042

(540) Renewal

KING'S

(511) 30

(210) No. 9394

(220) 29/05/2002

(732) Kuok Oils & Grains Pte Ltd.

No.1 Kim Seng Promenade, #05-01 Great
World City, 237994, Singapore

(111) No. 8923

(180) 14/09/2042

(540) Renewal

KING'S

(511) 31

(210) No. 9395

(220) 29/05/2002

(732) Kuok Oils & Grains Pte Ltd.

No.1 Kim Seng Promenade, #05-01 Great
World City, 237994, Singapore

(111) No. 8924

(180) 14/09/2042

(540) Renewal



(511) 25

(210) No. 9400

(220) 03/06/2002

(732) CAMPER S.L.

Poligono Industrial s/n, INCA 07300-
MALLORCA, Spain

(111) No. 8930

(180) 12/09/2042

(540) Renewal



(511) 30

(210) No. 9547

(220) 18/07/2002

(732) THAI ROONG RUENG CHILLI SAUCEE
CO., LTD

1/2 Moo6, Thapkarjuna Road, Kokkrabue,
Muang Samutsakorn 7400, Thailand

(111) No. 9075

(180) 15/09/2042

(540) Renewal



(511) 09

(210) No. 9814

(220) 06/12/2002

(732) Hanoi Battery Joint Stock Company

72 Phan Trong Tue Street, Van Dien Town,
Thanh Tri District, Hanoi City, Vietnam

(111) No. 9339

(180) 06/12/2032

(540) Renewal

CON THO

(511) 09

(210) No. 9815

(220) 06/12/2002

(732) Hanoi Battery Joint Stock Company.

72 Phan Trong Tue Street, Van Dien Town,
Thanh Tri District, Hanoi
City, Vietnam

(111) No. 9340

(180) 06/12/2032

(540) Renewal



(511) 29

(210) No. 25363

(220) 13/12/2011

(732) KUOK OILS & GRAINS PTE LTD.

No. 1 Kim Seng Promenade, #05-01 Great
World Cty, 237994, Singapore

(111) No. 24817

(180) 17/12/2021

(540) Renewal



(511) 30

(210) No. 25364

(220) 13/12/2011

(732) KUOK OILS & GRAINS PTE LTD.

No. 1 Kim Seng Promenade, #05-01 Great
World Cty, 237994, Singapore

(111) No. 24818

(180) 17/12/2031

(540) Renewal

HITACHI

(511) 07

(210) No. 25390

(220) 14/12/2011

(732) KABUSHIKI KAISHA HITACHI

SEISAKUSHO (d/b/a Hitachi, Ltd.)

6-6, Marunouchi 1-chome, Chiyoda-ku,

Tokyo, Japan

(111) No. 24819

(180) 27/05/2032

(540) Renewal

HITACHI

(511) 07

(210) No. 25389

(220) 14/12/2011

(732) KABUSHIKI KAISHA HITACHI (D/B/A

HITACHI, LTD.)

6-6, Marunouchi 1-chome, Chiyoda-ku,

Tokyo, Japan

(111) No. 24819

(180) 14/12/2031

(540) Renewal

HITACHI

(511) 07

(210) No. 25391

(220) 14/12/2011

(732) KABUSHIKI KAISHA HITACHI

SEISAKUSHO (d/b/a Hitachi, Ltd.)

6-6, Marunouchi 1-chome, Chiyoda-ku,

Tokyo, Japan

(111) No. 24820

(180) 27/05/2032

(540) Renewal

HITACHI

(511) 08

(210) No. 25392

(220) 14/12/2011

(732) KABUSHIKI KAISHA HITACHI

SEISAKUSHO (d/b/a Hitachi, Ltd.)

6-6, Marunouchi 1-chome, Chiyoda-ku,

Tokyo, Japan

(111) No. 24822

(180) 27/05/2032

(540) Renewal

HITACHI

(511) 09

(210) No. 25393

(220) 14/12/2011

(732) KABUSHIKI KAISHA HITACHI

SEISAKUSHO (d/b/a Hitachi, Ltd.)

6-6, Marunouchi 1-chome, Chiyoda-ku,

Tokyo, Japan

(111) No. 24823

(180) 27/05/2032

(540) Renewal

HITACHI

(511) 10

(210) No. 25394

(220) 14/12/2011

(732) KABUSHIKI KAISHA HITACHI

SEISAKUSHO (d/b/a Hitachi, Ltd.)

6-6, Marunouchi 1-chome, Chiyoda-ku,

Tokyo, Japan

(111) No. 24824

(180) 27/05/2032

(540) Renewal

HITACHI

(511) 11

(210) No. 25395

(220) 14/12/2011

(732) KABUSHIKI KAISHA HITACHI

SEISAKUSHO (d/b/a Hitachi, Ltd.)

6-6, Marunouchi 1-chome, Chiyoda-ku,

Tokyo, Japan

(111) No. 24825

(180) 27/05/2032

(540) Renewal

HITACHI

(511) 12

(210) No. 25396

(220) 14/12/2011

(732) KABUSHIKI KAISHA HITACHI

SEISAKUSHO (d/b/a Hitachi, Ltd.)

6-6, Marunouchi 1-chome, Chiyoda-ku,

Tokyo, Japan

(111) No. 24826

(180) 27/05/2032

(540) Renewal

HITACHI

(511) 35

(210) No. 25397

(220) 14/12/2011

(732) KABUSHIKI KAISHA HITACHI

SEISAKUSHO (d/b/a Hitachi, Ltd.)

6-6, Marunouchi 1-chome, Chiyoda-ku,

Tokyo, Japan

(111) No. 24827

(180) 27/05/2032

(540) Renewal

HITACHI

(511) 36

(210) No. 25398

(220) 14/12/2011

(732) KABUSHIKI KAISHA HITACHI

SEISAKUSHO (d/b/a Hitachi, Ltd.)

6-6, Marunouchi 1-chome, Chiyoda-ku,

Tokyo, Japan

(111) No. 24828

(180) 27/05/2032

(540) Renewal

HITACHI

(511) 37

(210) No. 25399

(220) 14/12/2011

(732) KABUSHIKI KAISHA HITACHI

SEISAKUSHO (d/b/a Hitachi, Ltd.)

6-6, Marunouchi 1-chome, Chiyoda-ku,

Tokyo, Japan

(111) No. 24829

(180) 27/05/2032

(540) Renewal

HITACHI

(511) 38

(210) No. 25400

(220) 14/12/2011

(732) KABUSHIKI KAISHA HITACHI

SEISAKUSHO (d/b/a Hitachi, Ltd.)

6-6, Marunouchi 1-chome, Chiyoda-ku,

Tokyo, Japan

(111) No. 24830

(180) 27/05/2032

(540) Renewal

HITACHI

(511) 39

(210) No. 25401

(220) 14/12/2011

(732) KABUSHIKI KAISHA HITACHI

SEISAKUSHO (d/b/a Hitachi, Ltd.)

6-6, Marunouchi 1-chome, Chiyoda-ku,

Tokyo, Japan

(111) No. 24831

(180) 27/05/2032

(540) Renewal

HITACHI

(511) 40

(210) No. 25402

(220) 14/12/2011

(732) KABUSHIKI KAISHA HITACHI

SEISAKUSHO (d/b/a Hitachi, Ltd.)

6-6, Marunouchi 1-chome, Chiyoda-ku,

Tokyo, Japan

(111) No. 24832

(180) 27/05/2032

(540) Renewal

HITACHI

(511) 41

(210) No. 25403

(220) 14/12/2011

(732) KABUSHIKI KAISHA HITACHI

SEISAKUSHO (d/b/a Hitachi, Ltd.)

6-6, Marunouchi 1-chome, Chiyoda-ku,

Tokyo, Japan

(111) No. 24833

(180) 14/12/2031

(540) Renewal

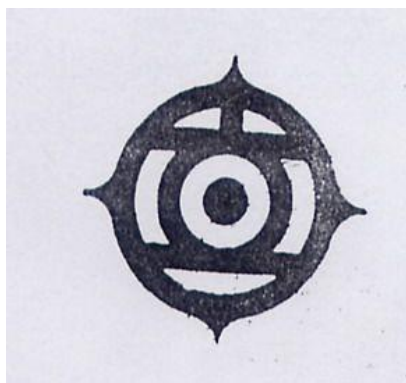

(511) 01

(210) No. 25405

(220) 14/12/2011

(732) KABUSHIKI KAISHA HITACHI

SEISAKUSHO (d/b/a Hitachi, Ltd.)

6-6, Marunouchi 1-chome, Chiyoda-ku,

Tokyo, Japan

(111) No. 24835

(180) 27/05/2032

(540) Renewal

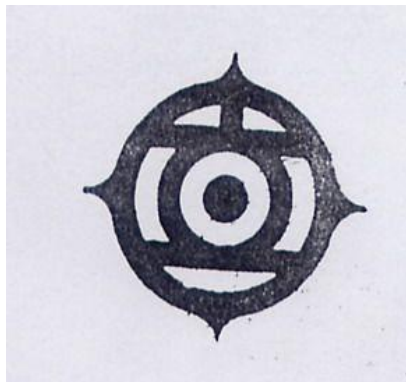

(511) 06

(210) No. 25406

(220) 14/12/2011

(732) KABUSHIKI KAISHA HITACHI
SEISAKUSHO (d/b/a Hitachi, Ltd.)
6-6, Marunouchi 1-chome, Chiyoda-ku,
Tokyo, Japan

(111) No. 24836

(180) 27/05/2032

(540) Renewal

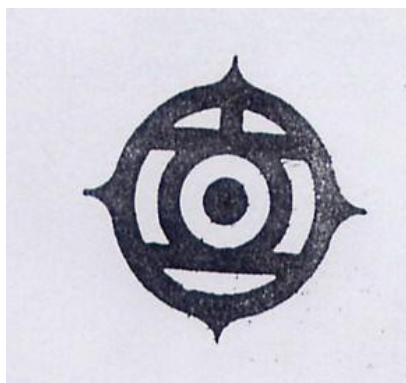

(511) 07

(210) No. 25407

(220) 14/12/2011

(732) KABUSHIKI KAISHA HITACHI
SEISAKUSHO (d/b/a Hitachi, Ltd.)
6-6, Marunouchi 1-chome, Chiyoda-ku,
Tokyo, Japan

(111) No. 24837

(180) 27/05/2032

(540) Renewal

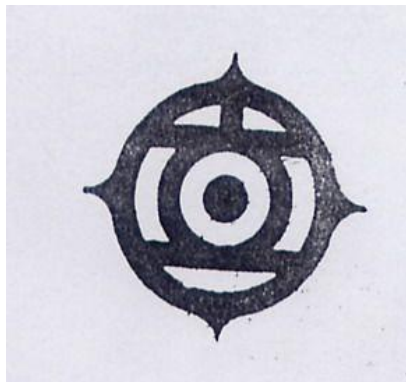

(511) 09

(210) No. 25408

(220) 14/12/2011

(732) KABUSHIKI KAISHA HITACHI
SEISAKUSHO (d/b/a Hitachi, Ltd.)
6-6, Marunouchi 1-chome, Chiyoda-ku,
Tokyo, Japan

(111) No. 24838

(180) 27/05/2032

(540) Renewal

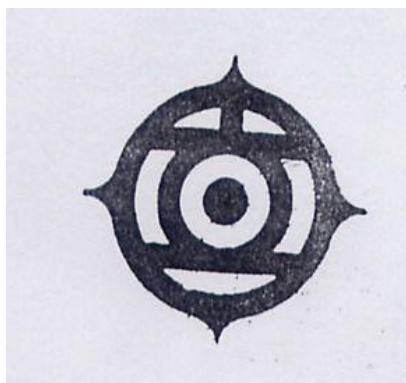

(511) 10

(210) No. 25409

(220) 14/12/2011

(732) KABUSHIKI KAISHA HITACHI
SEISAKUSHO (d/b/a Hitachi, Ltd.)
6-6, Marunouchi 1-chome, Chiyoda-ku,
Tokyo, Japan

(111) No. 24839

(180) 27/05/2032

(540) Renewal

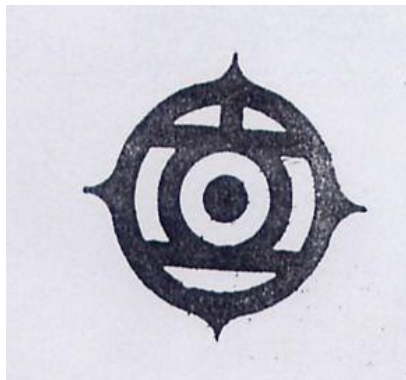

(511) 11

(210) No. 25410

(220) 14/12/2011

(732) KABUSHIKI KAISHA HITACHI
SEISAKUSHO (d/b/a Hitachi, Ltd.)
6-6, Marunouchi 1-chome, Chiyoda-ku,
Tokyo, Japan

(111) No. 24840

(180) 27/05/2032

(540) Renewal

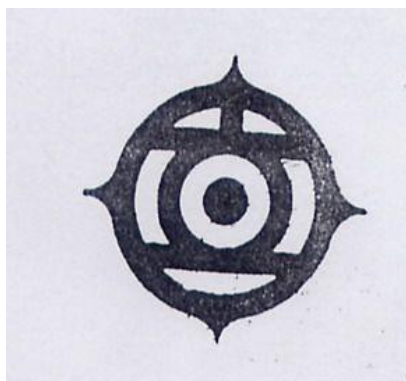

(511) 12

(210) No. 25411

(220) 14/12/2011

(732) KABUSHIKI KAISHA HITACHI
SEISAKUSHO (d/b/a Hitachi, Ltd.)
6-6, Marunouchi 1-chome, Chiyoda-ku,
Tokyo, Japan

(111) No. 24841

(180) 27/05/2032

(540) Renewal

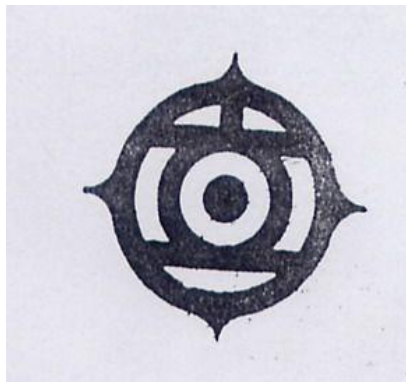

(511) 35

(210) No. 25412

(220) 14/12/2011

(732) KABUSHIKI KAISHA HITACHI
SEISAKUSHO (d/b/a Hitachi, Ltd.)
6-6, Marunouchi 1-chome, Chiyoda-ku,
Tokyo, Japan

(111) No. 24842

(180) 27/05/2032

(540) Renewal

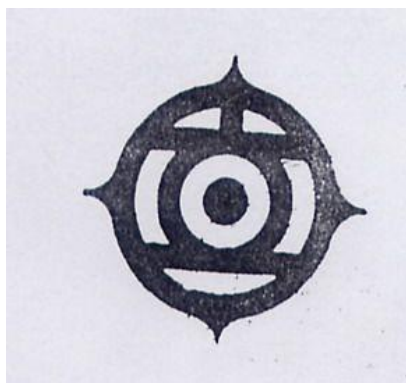

(511) 36

(210) No. 25413

(220) 14/12/2011

(732) KABUSHIKI KAISHA HITACHI
SEISAKUSHO (d/b/a Hitachi, Ltd.)
6-6, Marunouchi 1-chome, Chiyoda-ku,
Tokyo, Japan

(111) No. 24843

(180) 27/05/2032

(540) Renewal

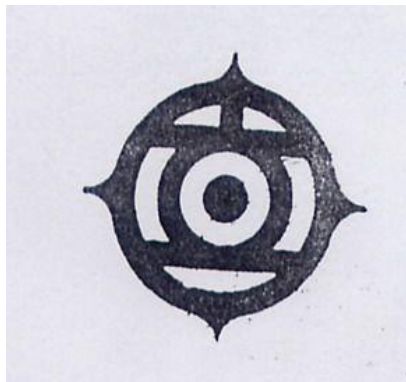

(511) 37

(210) No. 25414

(220) 14/12/2011

(732) KABUSHIKI KAISHA HITACHI
SEISAKUSHO (d/b/a Hitachi, Ltd.)
6-6, Marunouchi 1-chome, Chiyoda-ku,
Tokyo, Japan

(111) No. 24844

(180) 27/05/2032

(540) Renewal

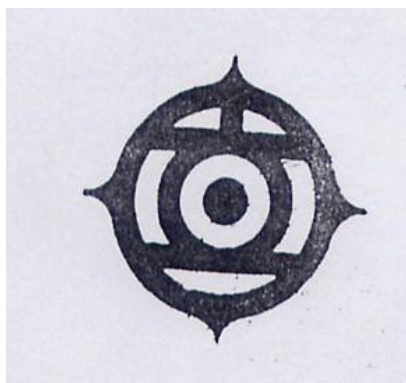

(511) 38

(210) No. 25415

(220) 14/12/2011

(732) KABUSHIKI KAISHA HITACHI
SEISAKUSHO (d/b/a Hitachi, Ltd.)
6-6, Marunouchi 1-chome, Chiyoda-ku,
Tokyo, Japan

(111) No. 24845

(180) 27/05/2032

(540) Renewal

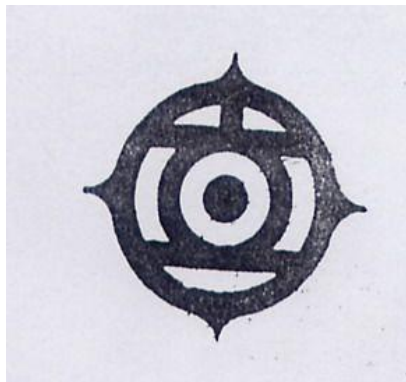

(511) 39

(210) No. 25416

(220) 14/12/2011

(732) KABUSHIKI KAISHA HITACHI
SEISAKUSHO (d/b/a Hitachi, Ltd.)
6-6, Marunouchi 1-chome, Chiyoda-ku,
Tokyo, Japan

(111) No. 24846

(180) 27/05/2032

(540) Renewal

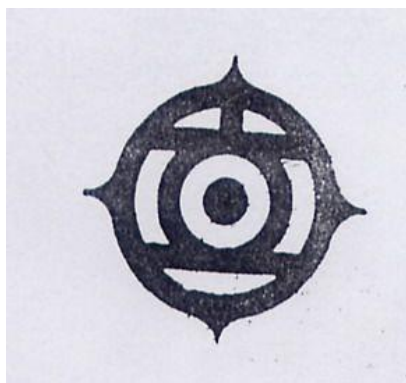

(511) 40

(210) No. 25417

(220) 14/12/2011

(732) KABUSHIKI KAISHA HITACHI
SEISAKUSHO (d/b/a Hitachi, Ltd.)
6-6, Marunouchi 1-chome, Chiyoda-ku,
Tokyo, Japan

(111) No. 24847

(180) 27/05/2032

(540) Renewal

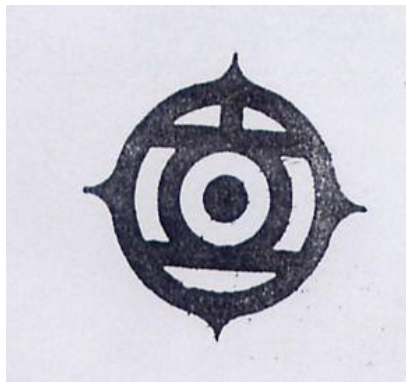

(511) 41

(210) No. 25418

(220) 14/12/2011

(732) KABUSHIKI KAISHA HITACHI
SEISAKUSHO (d/b/a Hitachi, Ltd.)
6-6, Marunouchi 1-chome, Chiyoda-ku,
Tokyo, Japan

(111) No. 24848

(180) 27/05/2032

(540) Renewal



HITACHI Device

(511) 08

(210) No. 26783

(220) 25/06/2012

(732) KABUSHIKI KAISHA HITACHI
SEISAKUSHO (d/b/a Hitachi, Ltd.)
6-6, Marunouchi 1-chome, Chiyoda-ku,
Tokyo, Japan

(111) No. 24937

(180) 27/05/2032

(540) Renewal

SONY

(511) 09

(210) No. 26089

(220) 28/03/2012

(732) Sony Corporation

1-7-1 Konan Minato-Ku, Tokyo, Japan

(111) No. 25317

(180) 28/03/2032

(540) Renewal

SONY

(511) 10

(210) No. 26090

(220) 28/03/2012

(732) Sony Corporation

1-7-1 Konan Minato-Ku, Tokyo, Japan

(111) No. 25318

(180) 28/03/2032

(540) Renewal

SONY

(511) 11

(210) No. 26091

(220) 28/03/2012

(732) Sony Corporation

1-7-1 Konan Minato-Ku, Tokyo, Japan

(111) No. 25319

(180) 28/03/2032

(540) Renewal

SONY

(511) 28

(210) No. 26092

(220) 28/03/2012

(732) Sony Corporation

1-7-1 Konan Minato-Ku, Tokyo, Japan

(111) No. 25320

(180) 28/03/2032

(540) Renewal

SONY

(511) 35

(210) No. 26093

(220) 28/03/2012

(732) Sony Corporation

1-7-1 Konan Minato-Ku, Tokyo, Japan

(111) No. 25321

(180) 28/03/2032

(540) Renewal

SONY

(511) 36

(210) No. 26094

(220) 28/03/2012

(732) Sony Corporation

1-7-1 Konan Minato-Ku, Tokyo, Japan

(111) No. 25322

(180) 28/03/2032

(540) Renewal

SONY

(511) 37

(210) No. 26095

(220) 28/03/2012

(732) Sony Corporation

1-7-1 Konan Minato-Ku, Tokyo, Japan

(111) No. 25323

(180) 28/03/2032

(540) Renewal

SONY

(511) 38

(210) No. 26096

(220) 28/03/2012

(732) Sony Corporation

1-7-1 Konan Minato-Ku, Tokyo, Japan

(111) No. 25324

(180) 28/03/2032

(540) Renewal

SONY

(511) 39

(210) No. 26097

(220) 28/03/2012

(732) Sony Corporation

1-7-1 Konan Minato-Ku, Tokyo, Japan

(111) No. 25325

(180) 28/03/2032

(540) Renewal

SONY

(511) 40

(210) No. 26098

(220) 28/03/2012

(732) Sony Corporation

1-7-1 Konan Minato-Ku, Tokyo, Japan

(111) No. 25326

(180) 28/03/2032

(540) Renewal

SONY

(511) 41

(210) No. 26099

(220) 28/03/2012

(732) Sony Corporation

1-7-1 Konan Minato-Ku, Tokyo, Japan

(111) No. 25327

(180) 28/03/2032

(540) Renewal

SONY

(511) 42

(210) No. 26100

(220) 28/03/2012

(732) Sony Corporation

1-7-1 Konan Minato-Ku, Tokyo, Japan

(111) No. 25328

(180) 28/03/2032

(540) Renewal

SONY

(511) 43

(210) No. 26101

(220) 28/03/2012

(732) Sony Corporation

1-7-1 Konan Minato-Ku, Tokyo, Japan

(111) No. 25329

(180) 28/03/2032

(540) Renewal

SONY

(511) 44

(210) No. 26102

(220) 28/03/2012

(732) Sony Corporation

1-7-1 Konan Minato-Ku, Tokyo, Japan

(111) No. 25330

(180) 28/03/2032

(540) Renewal

SONY

(511) 45

(210) No. 26103

(220) 28/03/2012

(732) Sony Corporation

1-7-1 Konan Minato-Ku, Tokyo, Japan

(111) No. 25331

(180) 28/03/2032

(540) Renewal

张 鸭 子

(511) 29

(210) No. 26307

(220) 03/05/2012

(732) CHONGQING YUANLU FOODS CO.,
LTD.

LIANGPING COUNTY INDUSTRIAL
PARK, CHONGQING CITY, CHINA

(111) No. 25622

(180) 13/11/2032

(540) Renewal



(511) 02

(210) No. 26389

(220) 11/05/2012

(732) PT. AVIA AVIAN TBK

Desa Wadungasih, Kecamatan Buduran,

Kabupaten Sidoarjo, Jawa Timur, Indonesia

(111) No. 25697

(180) 14/11/2032

(540) Renewal



(511) 02

(210) No. 26390

(220) 11/05/2012

(732) PT. AVIA AVIAN TBK

Desa Wadungasih, Kecamatan Buduran,

Kabupaten Sidoarjo, Jawa Timur, Indonesia

(111) No. 25698

(180) 14/11/2032

(540) Renewal



(511) 02

(210) No. 26391

(220) 11/05/2012

(732) PT. AVIA AVIAN TBK

Desa Wadungasih, Kecamatan Buduran,
Kabupaten Sidoarjo, Jawa Timur, Indonesia

(111) No. 25699

(180) 14/11/2032

(540) Renewal

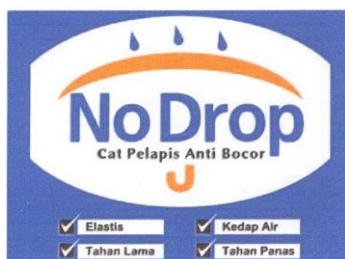

(511) 02

(210) No. 26392

(220) 11/05/2012

(732) PT. AVIA AVIAN TBK

Desa Wadungasih, Kecamatan Buduran,
Kabupaten Sidoarjo, Jawa Timur, Indonesia

(111) No. 25700

(180) 14/11/2032

ພາກທີ III

(Part III)

ເຄື່ອງໝາຍການຄ້າ

Trademarks

4. ການປ່ຽນແປງ

(Changes)

ພາກທີ III
(Part III)
ເຄື່ອງໝາຍການຄ້າ
Trademarks

5. ການດັດແກ້
(Amendments)

ພາກທີ IV
(Part IV)

ເຄື່ອງໝາຍການຄ້າຜ່ານລະບົບມາດຣິດ
Trademarks via Madrid Protocol

1. ຄໍາຮ້ອງ
(Applications)

ຄໍາອະທິບາຍກ່ຽວກັບລະຫັດຫຍໍ້
(Introduction of Codes)

- (540) ເຄື່ອງໝາຍການຄ້າ (Trademark)
- (511) ໝວດ (Nice Classification)
- (210) ເລກທີ ຄໍາຮ້ອງ (Number of the application)
- (220) ວັນທີ ຄໍາຮ້ອງ (Date of filing of the application)
- (732) ຊື່ ແລະ ທີ່ຢູ່ ຂອງຜູ້ຍື່ນຄໍາຮ້ອງ (Name and Address of applicant)

(540)

CICABIO

(511) 03, 05 and 44

(210) No. M/0939039

(220) 11/08/2022

(732) NAOS

355 rue Pierre-Simon Laplace F-13290 AIX-
EN-PROVENCE, France

(540)

RUNIHOL

(511) 05

(210) No. M/1134506

(220) 22/08/2022

(732) Scientific Technological Pharmaceutical Firm

"POLYSAN" Ltd.

Salova Street, 72, Bldg. 2, Liter A RU-192102
Saint Petersburg, Russian Federation

(540)

思造 SEZAO

(511) 06

(210) No. M/1681157

(220) 04/07/2022

(732) GUANGDONG HEGU HARDWARE

PRECISION MANUFACTURE CO., LTD.

Jieyang Industrial Transfer Industrial Park,

North Of Zhishui Street East Of Zhaohui

Road, China

(540)

Circlogy

(511) 03

(210) No. M/1681164

(220) 01/08/2022

(732) BANGAGAN COSMETICS CO., LTD

1F, 36-5 Geumhwa-ro 627beon-gil, Siheung-si

Gyeonggi-do, Republic of Korea

(540)



(511) 01

(210) No. M/1681167

(220) 13/07/2022

(732) Chongqing Fuyuan Chemical Co., Ltd
No. 100, Yantai Avenue, Yantai Town,
Dianjiang County, Chongqing, China

(540)



(511) 09

(210) No. M/1681194

(220) 15/07/2022

(732) BYD COMPANY LIMITED
No.1, Yan'an Road, Kuichong Street, Dapeng
New District 518000 Shenzhen, China

(540)

Acquaer

(511) 07

(210) No. M/1681197

(220) 15/07/2022

(732) LEO GROUP CO., LTD.

No.1 Leo Road, Binhai Town, Wenling City
317503 Zhejiang Province, China

(540)

Becoming

(511) 03, 05 and 35

(210) No. M/1681198

(220) 08/08/2022

(732) Guangzhou Gaoyuan Enterprise Management
Co., Ltd.

Room 3002, No.146, Linhe Middle Road,
Tianhe District, Guangzhou City Guangdong
Province, China

(540)



(511) 34

(210) No. M/1681267

(220) 05/07/2022

(732) Dongguan Williams Technology Co., Ltd.
Room 803, No.228 Chang 'an Zhen 'an Mid
Road, Chang 'an Town, Dongguan
Guangdong, China

(540)



(511) 09

(210) No. M/1681290

(220) 07/05/2022

(732) Shenzhen Coban Electronics Co., Ltd.
602, Bldg. C2, Xinqiao Industrial Park,
Tongfuyu Industrial Area, Xinhe Avenue,
Gonghe Community, Shajing Sub-District,
Bao'an District Shenzhen, China

(540)

Book of Ankh

(511) 09, 28 and 41

(210) No. M/1681471

(220) 07/04/2022

(732) Euro Games Technology Ltd.

"Maritsa" Str. 4, "Vranya-Lozen-Triugulnika"

BG-1151 Sofia, Bulgaria

(540)

Karnak Treasure

(511) 09, 28 and 41

(210) No. M/1681472

(220) 14/04/2022

(732) Euro Games Technology Ltd.

4, "Maritsa" Str., "Vranya-Lozen-Triugulnika"

BG-1151 Sofia, Bulgaria

(540)

TEKA
L I N E A

(511) 07 and 11

(210) No. M/1681510

(220) 24/03/2022

(732) TEKA INDUSTRIAL, S.A.

C/ Cajo, 17 E-39011 SANTANDER,
CANTABRIA, SPAIN

(540)

DAIO

(511) 01, 03, 05, 07, 08, 09, 10, 16, 20, 21, 24, 25, 31,
35, 37, 39, 40 and 41

(210) No. M/1681614

(220) 24/02/2022

(732) DAIO PAPER CORPORATION

2-60, Mishima-Kamiya-cho, Shikokuchuo-shi
Ehime-ken 799-0402, Japan

(540)



(511) 14

(210) No. M/1681626

(220) 05/05/2022

(732) Guangxi Nanko Copper Company Limited
Guangxi China-ASEN Youth Industrial Park,
Quli Town, Fusui County, Chongzuo City
Guangxi Zhuang Autonomous Region, China

(540)



(511) 09

(210) No. M/1681663

(220) 15/07/2022

(732) BYD COMPANY LIMITED
No. 1, Yan'an Road, Kuichong Street, Dapeng
New District 518000 Shenzhen, China

(540)

jiaxipera

(511) 07

(210) No. M/1681730

(220) 13/05/2022

(732) JIAXIPERA COMPRESSOR CO.,LTD

No. 588, Yazhong Road, Daqiao Town,
Nanhu District, Jiaxing City 314000 Zhejiang
Province, China

(540)

Blue Lotus

(511) 07

(210) No. M/1681742

(220) 20/07/2022

(732) SHISHI ZHUOCHENG MACHINERY

AUTOMATION EQUIPMENT CO., LTD.

Times Industrial Building, No. 20, Xiangjiang
Road, Shishi City, Quanzhou City 362200
Fujian Province, China

(540)



(511) 03, 05 and 10

(210) No. M/1681748

(220) 28/05/2022

(732) NINGBO LVTANG BIOTECHNOLOGY
CO., LTD.

No. 9 Dongpu Road, Chengdong Industrial
Park, Daxu Town, Xiangshan, Ningbo 100080
Zhejiang, China

(540)

NOMI

(511) 09

(210) No. M/1681770

(220) 07/04/2022

(732) NIO CO., LTD.

SUITE 115, 569 ANCHI ROAD, ANTING
TOWN, JIADING DISTRICT 201805
SHANGHAI, CHINA

(540)

The logo for Tokopedia, featuring the word "tokopedia" in a lowercase, green, sans-serif font. The letters are slightly shadowed, giving it a 3D effect as if it's floating above a surface.

(511) 35

(210) No. M/1681771

(220) 19/05/2022

(732) PT Tokopedia

Tokopedia Tower, 52nd Floor, Jalan Prof. Dr.
Satrio Kav 11, Kelurahan Karet Semanggi,
Kecamatan Setiabudi Jakarta Selatan 12940,
Indonesia

(540)

The logo for Xuping Jewelry. It features a large, stylized black 'X' at the top. Below it, the word "XUPING" is written in a bold, black, sans-serif font. Underneath "XUPING", the word "JEWELRY" is written in a smaller, black, sans-serif font, flanked by two horizontal lines.

(511) 14

(210) No. M/1681853

(220) 29/03/2022

(732) Xuping Jewelry Co.,LTD.

No. 60, Industrial Avenue, Longxu Town,
Longxu Area, Wuzhou City Guangxi
Autonomous Region, China

(540)

NVGTN

(511) 25

(210) No. M/1681867

(220) 29/07/2022

(732) NVGTN, LLC

Apt. 546, 7616 West Courtney Campbell
Causeway Tampa FL 33607,
United States of America

(540)



(511) 09, 28 and 41

(210) No. M/1681943

(220) 14/04/2022

(732) Euro Games Technology Ltd.

"Maritsa" Str. 4, "Vranya-Lozen-Triugulnika"
BG-1151 Sofia, Bulgaria

(540)



(511) 03

(210) No. M/1681961

(220) 26/05/2022

(732) Oba Cosmetic (Xiamen) Co., Ltd.

10G-3, No.267 Jiahe Road, Siming District,
Xiamen City Fujian Province, China

(540)



(511) 01, 05, 09, 10, 35, 42 and 44

(210) No. M/1682035

(220) 28/12/2021

(732) BioNTech SE

An der Goldgrube 12 55131 Mainz, Germany

(540)

Book of Sirius

(511) 09, 28 and 41

(210) No. M/1682049

(220) 07/04/2022

(732) Euro Games Technology Ltd.

"Maritsa" Str. 4, "Vranya-Lozen-Triugulnika"

BG-1151 Sofia, Bulgaria

ພາກທີ IV

(Part IV)

ເຄື່ອງໝາຍການຄ້າຜ່ານລະບົບມາດຣິດ

Trademarks via Madrid Protocol

2. ຜົນການຈົດທະບຽນ

(Registration)

ຄຳອະທິບາຍກ່ຽວກັບລະຫັດຫຍໍ້

(Introduction of Codes)

- (540) ເຄື່ອງໝາຍການຄ້າ (Trademark)
- (511) ໝວດ (Nice Classification)
- (210) ເລກທີ ຄຳຮ້ອງ (Number of the application)
- (220) ວັນທີ ຍື່ນຄຳຮ້ອງ (Date of filing of the application)
- (732) ຊື່ ແລະ ທີ່ຢູ່ ຂອງຜູ້ຍື່ນຄຳຮ້ອງ (Name and Address of applicant)
- (111) ເລກທີການຈົດທະບຽນເຄື່ອງໝາຍການຄ້າ (Number of the registration)
- (180) ວັນໝົດອາຍຸຂອງການຈົດທະບຽນ (Expiration date of the registration)

(540)



(511) 03, 04, 05 and 21

(210) No. M/1484769

(220) 06/10/2021

(732) L.C. DURANTE SPA

Viale Angelico 87/89 I-00195 ROMA, Italy

(111) No. M/1484769

(180) 06/12/2028

(540)

功夫链

(511) 05, 09, 10, 25 and 29

(210) No. M/1642873

(220) 19/10/2021

(732) Fuli Technology (Shanghai) Co., Ltd.

Room 403, No. 356 Xinzha Road, Huangpu

District 200001 Shanghai City, China

(111) No. M/1642873

(180) 19/10/2031

(540)



(511) 09, 38 and 41

(210) No. M/1643489

(220) 04/10/2021

(732) beIN Media Group LLC

beIN Sports Building, TV & Radio Complex,
TV Roundabout, Bin Omran, Doha, Qatar

(111) No. M/1643489

(180) 04/10/2031

(540)



(511) 09

(210) No. M/1643516

(220) 19/10/2021

(732) Zhejiang Chint Electrics Co., Ltd.

No. 1 Chint Road, Chint Industrial Zone,
North Baixiang, Yueqing City 325603
Zhejiang Province, China

(111) No. M/1643516

(180) 19/10/2031

(540)



(511) 05, 29, 30, 31, 32, 33 and 35

(210) No. M/1643533

(220) 01/12/2021

(732) aT (Korea Agro-Fisheries & Food Trade Corporation)

227, Munhwa-ro, Naju-si Jeollanam-do,
Republic of Korea

(111) No. M/1643533

(180) 01/12/2031

(540)

TOD

(511) 09, 38 and 41

(210) No. M/1643638

(220) 04/10/2021

(732) beIN Media Group LLC

beIN Sports Building, TV & Radio Complex,
TV Roundabout, Bin Omran, Doha, Qatar

(111) No. M/1643638

(180) 04/10/2031

(540)



(511) 36 and 37

(210) No. M/1644039

(220) 08/11/2021

(732) HUAWEI TECHNOLOGIES CO., LTD.

Administration Building, Huawei

Technologies Co., Ltd., Bantian, Longgang

District Shenzhen, China

(111) No. M/1644039

(180) 08/11/2031

(540)

FoxTrax

(511) 09, 35, 38 and 39

(210) No. M/1644102

(220) 11/10/2021

(732) Linfox Australia Pty Ltd

55 English Street ESSENDON FIELDS VIC

3041, Australia

(111) No. M/1644102

(180) 11/10/2031

(540)

NISHA

(511) 03

(210) No. M/1644109

(220) 06/10/2021

(732) JETHARAM NEMARAM GEHLOT

101, Shree White Heights, Saraswati Nagar,

Hirawadi Road, Panchavati, Nashik

Maharashtra 422 003, India

(111) No. M/1644109

(180) 06/10/2031

(540)

NKH

(511) 42

(210) No. M/1644294

(220) 04/10/2021

(732) NKH Solution Sdn Bhd

5A-4, Block F1, Jalan PJU 1/42, Dataran

Prima 47301 Petaling Jaya Selangor, Malaysia

(111) No. M/1644294

(180) 04/10/2031

(540)

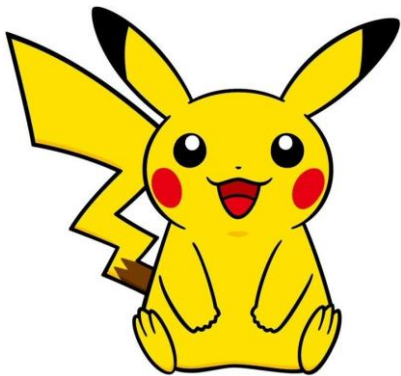

(511) 03, 05, 09, 11, 14, 15, 16, 18, 20, 21, 24, 25,
26, 27, 28, 29, 30, 32, 41 and 43

(210) No. M/1644320

(220) 19/11/2021

(732) Nintendo Co., Ltd.

11-1, Hokotate-cho, Kamitoba, Minami-ku,
Kyoto-shi Kyoto 601-8501, Japan

(111) No. M/1644320

(180) 19/11/2031

ພາກທີ IV

(Part IV)

ເຄື່ອງໝາຍການຄ້າຜ່ານລະບົບມາດຣິດ

Trademarks via Madrid Protocol

3. ຜົນການຕໍ່ອາຍຸ

(Renewal)

ຄຳອະທິບາຍກ່ຽວກັບລະຫັດຫຍໍ້

(Introduction of Codes)

- (540) ເຄື່ອງໝາຍການຄ້າ (Trademark)
- (511) ໝວດ (Nice Classification)
- (210) ເລກທີ ຄຳຮ້ອງ (Number of the application)
- (220) ວັນທີ ຍື່ນຄຳຮ້ອງ (Date of filing of the application)
- (732) ຊື່ ແລະ ທີ່ຢູ່ ຂອງຜູ້ຍື່ນຄຳຮ້ອງ (Name and Address of applicant)
- (111) ເລກທີການຈົດທະບຽນເຄື່ອງໝາຍການຄ້າ (Number of the registration)
- (180) ການຕໍ່ອາຍຸຂອງການຈົດທະບຽນ (Expiration date of the renewal)

ພາກທີ IV

(Part IV)

ເຄື່ອງໝາຍການຄ້າຜ່ານລະບົບມາດຣິດ

Trademarks via Madrid Protocol

4. ການປ່ຽນແປງ

(Changes)

ພາກທີ IV

(Part IV)

ເຄື່ອງໝາຍການຄ້າຜ່ານລະບົບມາດຣິດ

Trademarks via Madrid Protocol

5. ການດັດແກ້

(Amendments)

ພາກທີ V
(Part V)
ຖິ່ນກຳເນີດ
Geographical Indications

1. ຄຳຮ້ອງ
(Applications)

ພາກທີ V
(Part V)
ຖິ່ນກຳເນີດ
Geographical Indications

2. ຜົນການຈົດທະບຽນ
(Registration)

ພາກທີ V

(Part V)

ຖິ່ນກຳເນີດ

Geographical Indications

3. ການປ່ຽນແປງ

(Changes)

ພາກທີ V
(Part V)
ຖິ່ນກຳເນີດ
Geographical Indications

4. ການດັດແກ້
(Amendments)

ພາກທີ VI

(Part VI)

ພັນພືດໃໝ່

New Plant Varieties

1. ຄໍາຮ້ອງ

(Applications)

ພາກທີ VI

(Part VI)

ພັນພືດໃໝ່

New Plant Varieties

2. ຜົນການຈັດທະບຽນ

(Registration)

ພາກທີ VI

(Part VI)

ພັນພືດໃໝ່

New Plant Varieties

3. ການປ່ຽນແປງ

(Changes)

ພາກທີ VI

(Part VI)

ພັນພືດໃໝ່

New Plant Varieties

4. ການດັດແກ້

(Amendments)

ພາກທີ VII

(Part VII)

ລິຂະສິດ ແລະ ສິດກ່ຽວຂ້ອງກັບລິຂະສິດ

Copyrights and Related Rights

1. ການແຈ້ງຂໍ້ມູນ

(Notifications)

ພາກທີ VII

(Part VII)

ລິຂະສິດ ແລະ ສິດກ່ຽວຂ້ອງກັບລິຂະສິດ

Copyrights and Related Rights

2. ການປ່ຽນແປງ

(Changes)

ພາກທີ VIII

(Part VIII)

**ການແກ້ໄຂຂໍ້ຂັດແຍ່ງທາງດ້ານບໍລິຫານກ່ຽວກັບການຈົດທະບຽນຊັບ
ສິນອຸດສາຫະກຳ ແລະ ພັນພືດໃໝ່**

**Administrative Dispute Resolutions on the Registration of
Industrial Property and New Plant Varieties**

1. ຜົນການຄັດຄ້ານຄຳຮ້ອງ

(Result of Oppositions)

ພາກທີ VIII

(Part VIII)

**ການແກ້ໄຂຂໍ້ຂັດແຍ່ງທາງດ້ານບໍລິຫານກ່ຽວກັບການຈັດທະບຽນຊັບ
ສິນອຸດສາຫະກຳ ແລະ ພັນພືດໃໝ່**

**Administrative Dispute Resolutions on the Registration of
Industrial Property and New Plant Varieties**

2. ຜົນການແຈ້ງປະຕິເສດ

(Result of Refusals)

ພາກທີ VIII

(Part VIII)

**ການແກ້ໄຂຂໍ້ຂັດແຍ່ງທາງດ້ານບໍລິຫານກ່ຽວກັບການຈົດທະບຽນຊັບ
ສິນອຸດສາຫະກຳ ແລະ ພັນພືດໃໝ່**

**Administrative Dispute Resolutions on the Registration of
Industrial Property and New Plant Varieties**

**3. ຜົນການຍົກເລີກ ຫຼື ລົບລ້າງ ຂອງການຈົດທະບຽນ
(Result of Cancellation or Invalidation of Registration)**