



ສາທາລະນະລັດ ປະຊາທິປະໄຕ ປະຊາຊົນລາວ  
LAO PEOPLE'S DEMOCRATIC REPUBLIC

ກະຊວງ ອຸດສາຫະກຳ ແລະ ການຄ້າ  
ກົມຊັບສິນທາງປັນຍາ  
MINISTRY OF INDUSTRY AND COMMERCE  
DEPARTMENT OF INTELLECTUAL PROPERTY

ຈົດໝາຍເຫດທາງລັດຖະການ  
ກ່ຽວກັບ ຊັບສິນທາງປັນຍາ  
ຢູ່ ສປປ ລາວ

OFFICIAL GAZETTE ON INTELLECTUAL PROPERTY  
IN LAO PDR

# ພາກທີ I

## (Part I)

### ສິດທິບັດ ແລະ ອະນຸສິດທິບັດ (Patent and Petty Patent)

#### 1. ຄໍາຮ້ອງ (Applications)

##### ຄໍາອະທິບາຍກ່ຽວກັບລະຫັດຫຍໍ້ (Introduction of Codes)

- (21) ເລກທີ ຄໍາຮ້ອງ (Filing Number)
- (22) ວັນທີ ຍືນຄໍາຮ້ອງ (Filing Date)
- (30) ວັນທີ ບຸລິມະສິດ (Priority Date)
- (43) ວັນທີເຜີຍແຜ່ (Publication Date)
- (51) ໝວດ (International Patent Classification)
- (54) ຊື່ຂອງການປະດິດ (Title)
- (57) ບົດຄັດຫຍໍ້ (Abstract)
- (71) ຊື່ ແລະ ທີ່ຢູ່ ເຈົ້າຂອງສິດທິບັດ ແລະ ອະນຸສິດທິບັດ (Owner Name and Address)
- (72) ຊື່ຜູ້ປະດິດ (Inventor Name)
- (74) ຊື່ຕົວແທນ (Representative Name)
- (55) ຮູບພາບ (Pictures)

# ພາກທີ I

## (Part I)

### ສິດທິບັດ ແລະ ອະນຸສິດທິບັດ (Patent and Petty Patent)

#### 2. ຜົນການອອກສິດທິບັດ ແລະ ອະນຸສິດທິບັດ (Grant of Patents and Petty Patents)

##### ຄຳອະທິບາຍກ່ຽວກັບລະຫັດຫຍໍ້

##### (Introduction of Codes)

- (11) ເລກທິ (Grant Number)
- (21) ເລກທິ ຄຳຮ້ອງ (Filing Number)
- (22) ວັນທິຍືນຄຳຮ້ອງ (Filing Date)
- (30) ວັນທິ ບຸລິມະສິດ (Priority Date)
- (43) ວັນທິເຜີຍແຜ່ (Publication Date)
- (51) ໝວດ (International Patent Classification)
- (54) ຫົວຂໍ້ການປະດິດ (Title)
- (57) ບົດຄັດຫຍໍ້ (Abstract)
- (71) ຊື່ ແລະ ທີ່ຢູ່ ເຈົ້າຂອງສິດທິບັດ ແລະ ອະນຸສິດທິບັດ (Owner Name and Address)
- (72) ຊື່ຜູ້ປະດິດ (Inventor Name)
- (74) ຊື່ຕົວແທນ (Representative Name)
- (55) ຮູບພາບ (Pictures)

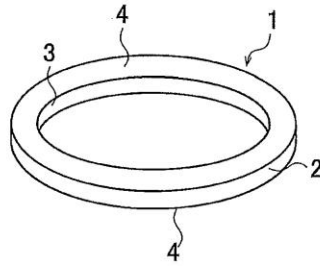
Official Gazette of Industrial Property Vol. 359, 05/06/2026

- (11) No. 724
- (21) PA 724
- (22) 10/07/2020
- (30) 2018-234741 14/12/2018 JP and 62/624,987 01/02/2018 US
- (43) 20/02/2026
- (51) Int.Cl.G 11B 23/00(2006.01), G 11B 17/038(2006.01)
- (54) ສະເປດເຊີແກ້ວ, ອຸປະກອນອ່ານຮາດດິສ, ແລະ ວິທີການເພື່ອຜະລິດ ສະເປດເຊີແກ້ວ
- (57) ວັດສະດຸແກ້ວຂອງສະເປດເຊີແກ້ວ ມີຄວາມຕ້ານທານພື້ນຜິວ ຄື  $10^3$  ຫາ  $10^9$  [ $\Omega/\text{sq}$ ] ທີ່  $22^\circ\text{C}$ . ຄວາມຕ້ານທານພື້ນຜິວຂອງພື້ນຜິວຂອງວັດສະດຸແກ້ວຂອງສະເປດເຊີແກ້ວທີ່  $22$  [ $^\circ\text{C}$ ] ແມ່ນຕໍ່າກວ່າຄວາມຕ້ານທານພື້ນຜິວສັດສ່ວນພາຍໃນຂອງວັດສະດຸແກ້ວທີ່  $22$  [ $^\circ\text{C}$ ]. ສະເປດເຊີແກ້ວປະກອບມີຢ່າງໜ້ອຍສຸດໜຶ່ງອີກຊິດທີ່ຖືກຄັດເລືອກຈາກກຸ່ມຊຶ່ງປະກອບດ້ວຍ  $\text{TiO}_2$ ,  $\text{Nb}_2\text{O}_5$ ,  $\text{WO}_3$  ແລະ  $\text{Bi}_2\text{O}_3$ . ທີ່ເປັນອົງປະກອບຂອງແກ້ວ.
- (71) HOYA CORPORATION  
6-10-1 Nishi-Shinjuku, Tokyo 1608347, Japan.
- (72) OSAKABE, Kinobu; EDA, Shinji; TANNO, Yoshitake and IKENISHI, Mikio.
- (74) Tilleke & Gibbins Lao Co.,Ltd.
- (55)

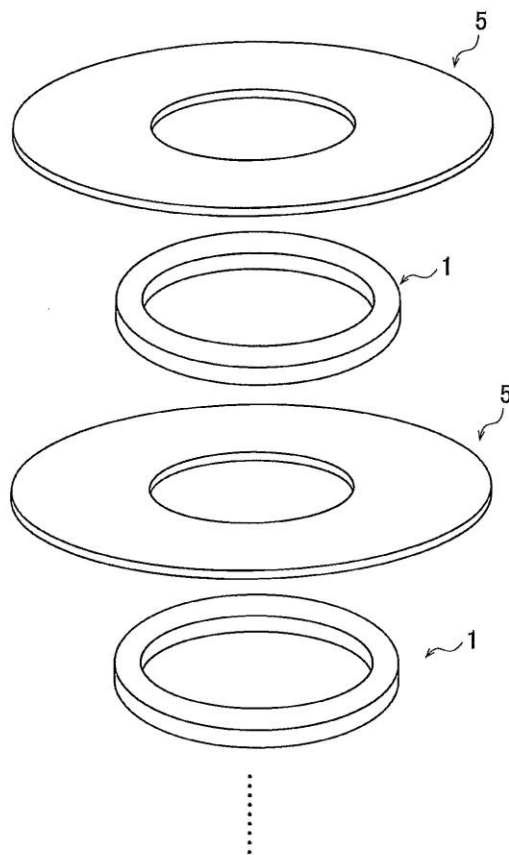
WO 2019/151459

PCT/JP2019/003533

[図1]



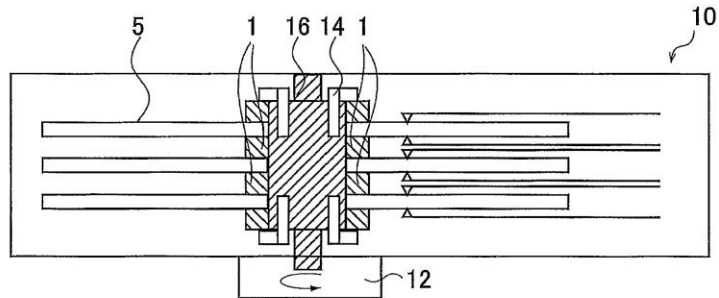
[図2]



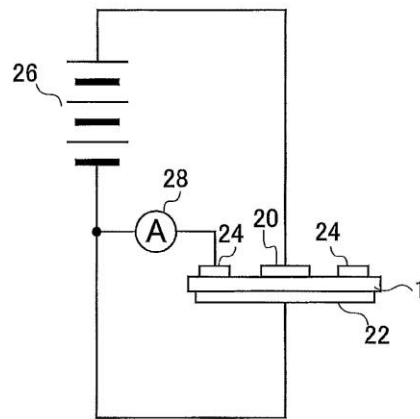
WO 2019/151459

PCT/JP2019/003533

[圖3]



[圖4]



- (11) No. 734
- (21) PA 734
- (22) 28/09/2020
- (30) 201810264064.0 28/03/2018 CN
- (43) 20/02/2026
- (51) Int.C1.C 02F 3/30(2006.01), E 04H 14/00(2006.01)
- (54) ECOLOGICAL BUILDING WITH ORGANIC AGRICULTURAL AQUACULTURE FUNCTION AND INTERNAL CIRCULATION TREATMENT FUNCTION
- (57) Disclosed is an ecological building with an organic agricultural aquaculture function and an internal circulation treatment function. The ecological building comprises a production maintenance passage (20) arranged on the building and located on an elevation of an external wall of each storey. Replaceable planting boxes (3) are arranged on an external wall of the building, each kitchen in the building is provided with a garbage crusher, and each toilet in the building is provided with a vacuum toilet system. A biogas digester (7) is in communication with a vacuum base station (8), the vacuum base station (8) is connected to the vacuum toilet system via a vacuum pipeline (10), the biogas digester (7) is in communication with a biogas slurry storage pool via a biogas slurry pipeline (11), and an inlet end of the biogas digester (7) is connected to a discharge port of the garbage crusher via a black water delivery pipeline (12). The ecological building realizes ecological environmental protection and zero discharge of household garbage, and has an organic agriculture production function and an internal circulation treatment function..
- (71) SONG, Zhiyuan  
No. 1The First Tang Hu West Rd., Shuangliu Country, Chengdu, Sichuan 610000, P.R., China.
- (72) SONG, Zhiyuan.
- (74) Tilleke & Gibbins International Ltd.
- (55)

WO 2019/184087

PCT/CN2018/090171

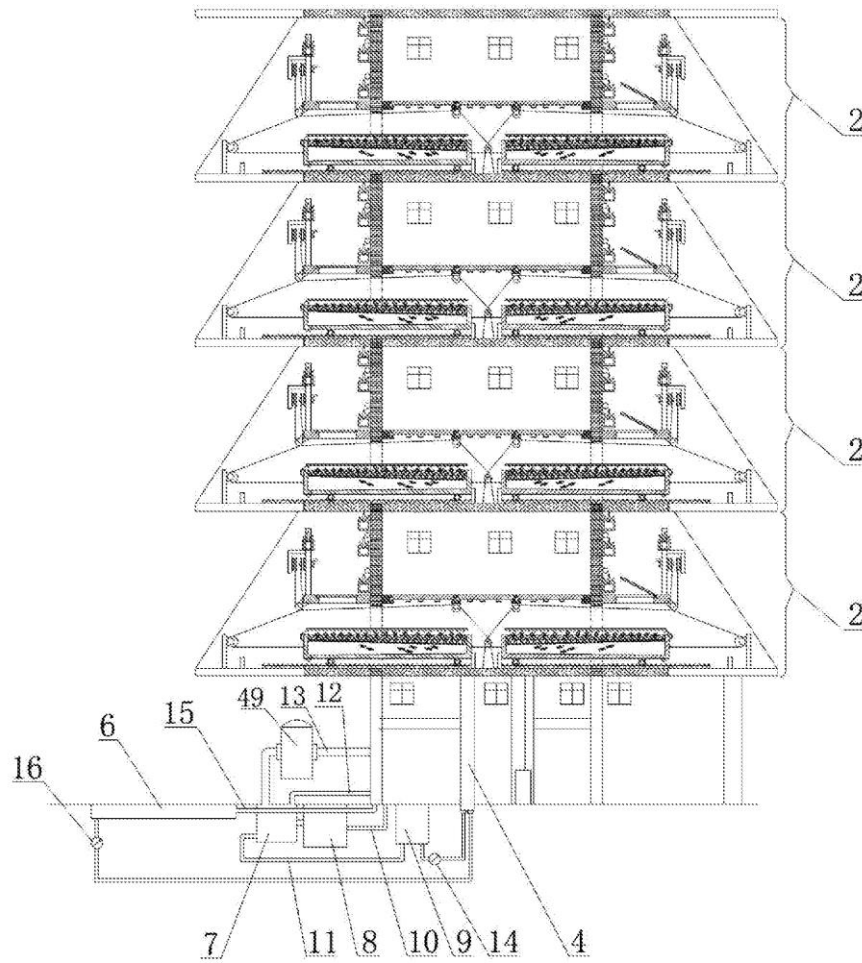


图 1

WO 2019/184087

PCT/CN2018/090171

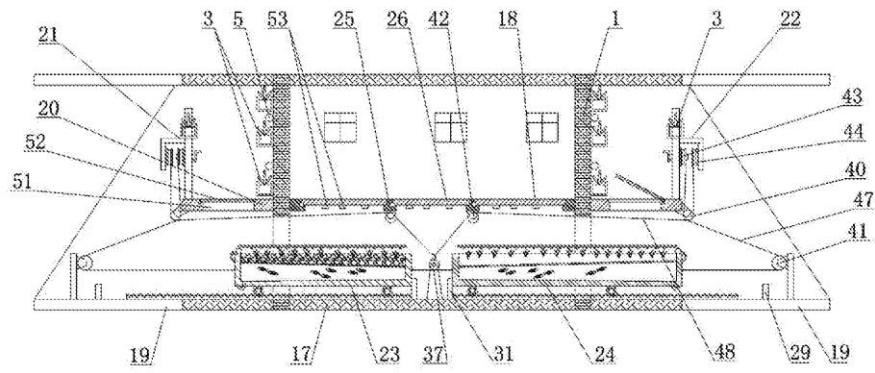


图 2

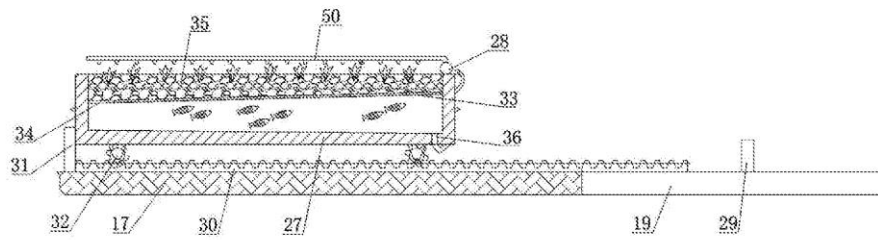


图 3

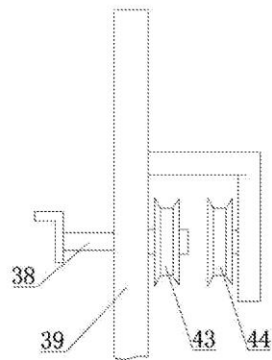


图 4

WO 2019/184087

PCT/CN2018/090171

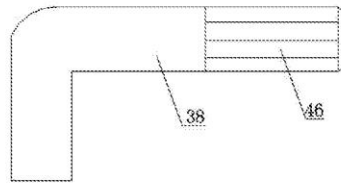


图 5

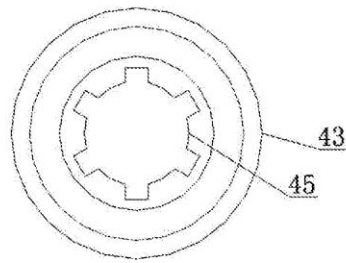


图 6

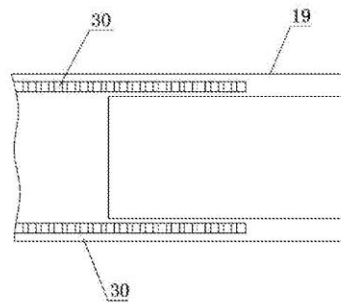
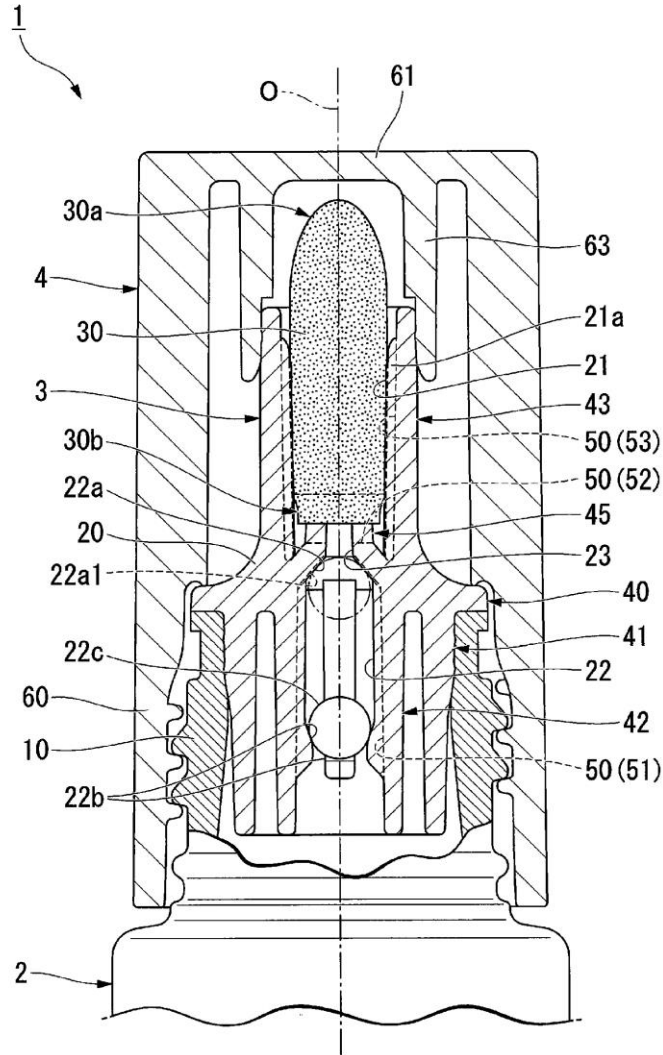


图 7

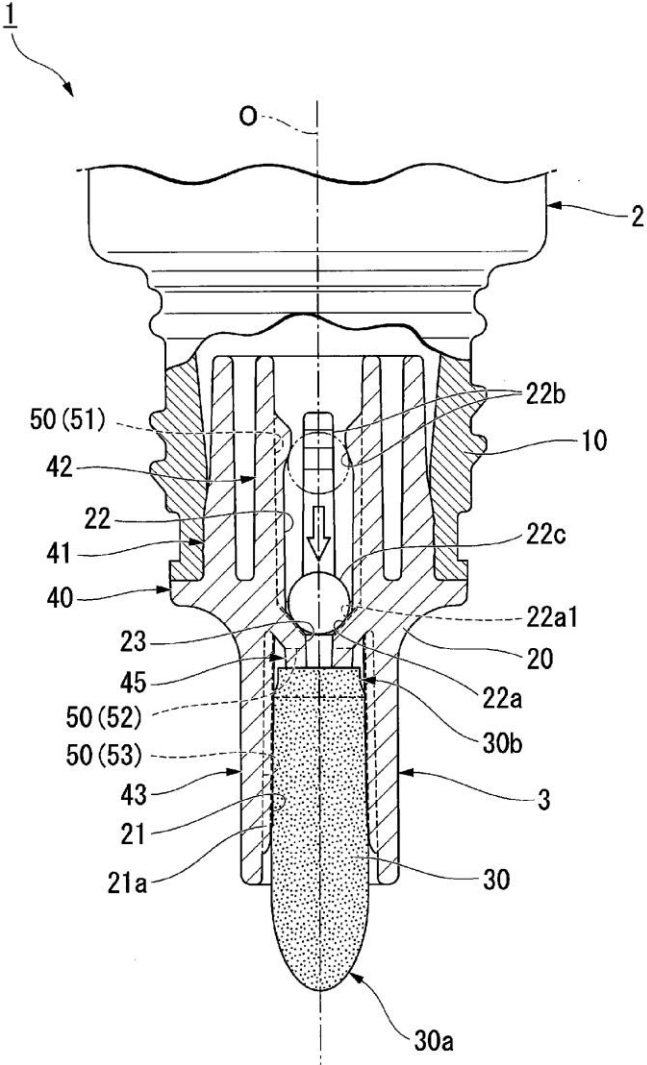
Official Gazette of Industrial Property Vol. 359, 05/06/2026

- (11) No. 745
- (21) PA 745
- (22) 25/11/2020
- (30) 2018-105125 31/05/2018 JP and 2018-135943 19/07/2018 JP
- (43) 27/02/2026
- (51) Int.Cl.B 65D 83/00(2006.01), B 65D 47/42(2006.01)
- (54) ພາຊະນະປະຍຸກ
- (57) ພາຊະນະປະຍຸກ (1) ປະກອບມີລຳຕົວຫລັກຂອງພາຊະນະ (2); ສ່ວນຂອງປັກສຽບພາຍໃນ(20); ແລະ ວັດສະດຸເຮັດໃຫ້ຊຸ່ມ (30). ສ່ວນຂອງປັກສຽບພາຍໃນ (20) ປະກອບມີສ່ວນຮອງຮັບວັດສະດຸເຮັດໃຫ້ຊຸ່ມ (21), ແລະ ສ່ວນຮອງຮັບລຳຕົວວາວ (22) ຊຶ່ງປະກອບມີ ປ່າວາວ (22a) ເທິງດ້ານຂ້າງ ຂອງສ່ວນຮອງຮັບວັດສະດຸເຮັດໃຫ້ຊຸ່ມ (21) ແລະ ສ່ວນຄໍ້າຈຸນລຳຕົວວາວ (22b) ເທິງດ້ານຂ້າງລຳຕົວຫລັກຂອງພາຊະນະ (2) ແລະ ສ່ວນຄໍ້າຈຸນລຳຕົວວາວ (22b). ຮອງການສື່ສານ (50) ຊຶ່ງປະກອບເປັນຊ່ວງຫວ່າງ ລະຫວ່າງລຳຕົວວາວ (22ຄ) ແລະ ສ່ວນຮອງຮັບລຳຕົວຂອງວາວ (22) ໃນສະພາບ ທີ່ລຳຕົວຂອງວາວ (22c) ໄດ້ຮັບການຄໍ້າຈຸນດ້ວຍສ່ວນຄໍ້າຈຸນລຳຕົວຂອງວາວ (22b) ທີ່ຖືກສ້າງຂຶ້ນ. .
- (71) SATO PHARMACEUTICAL CO., LTD.  
5-27, Motoakasaka 1-chome, Minato-ku, Tokyo 107-0051, Japan.
- (72) SAKATA KOTA..
- (74) LAO INTERCONSULT CO., LTD. (LICO).
- (55)

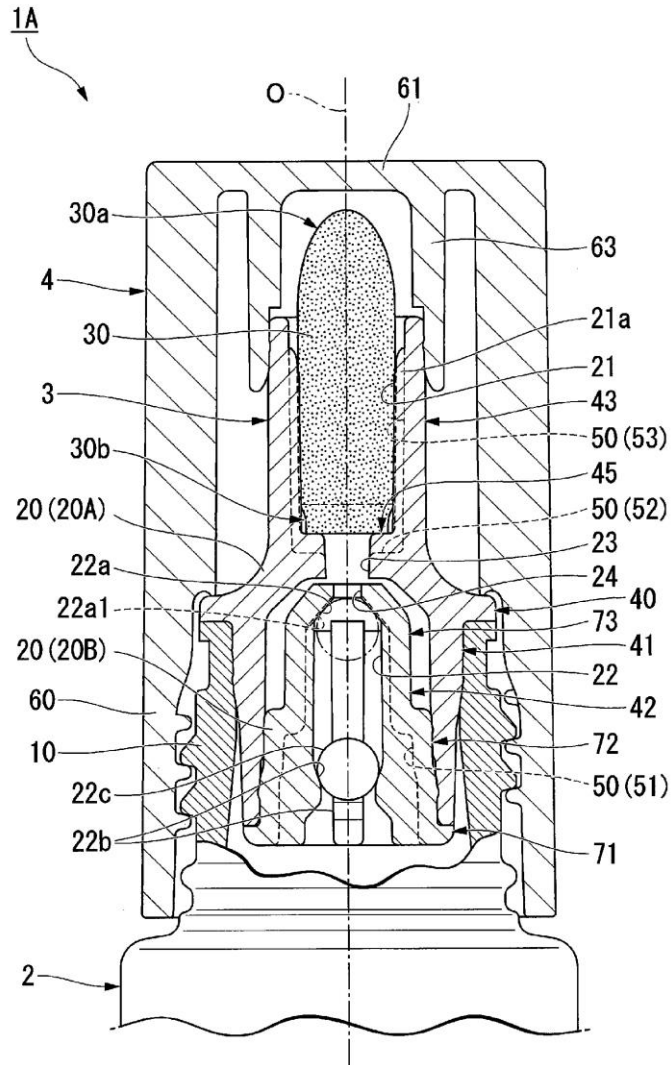
[図1]



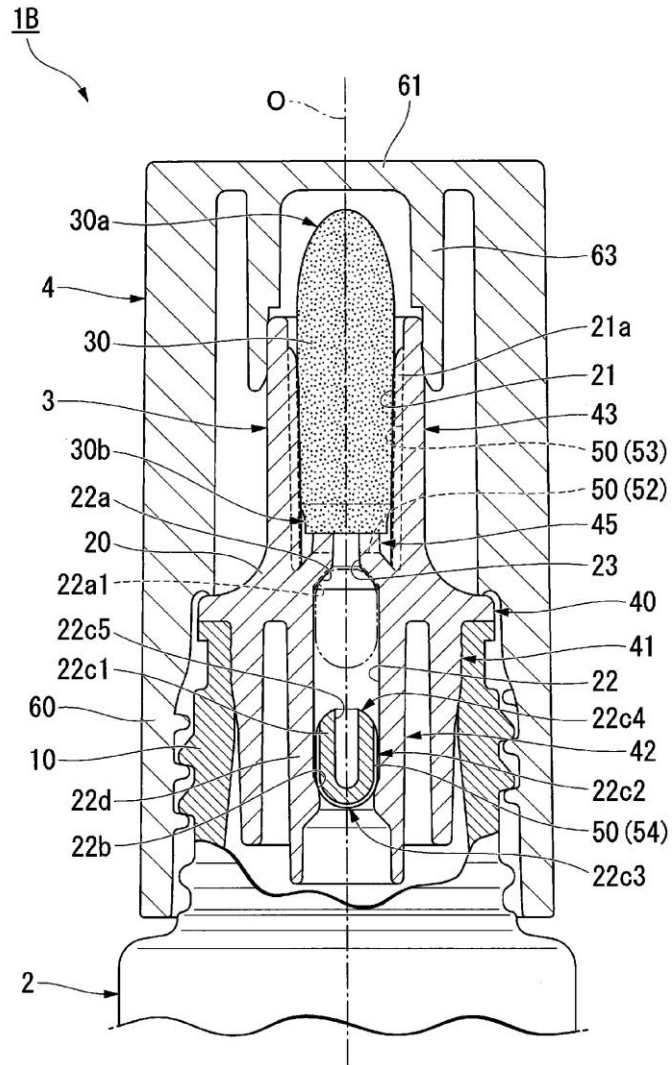
[圖2]



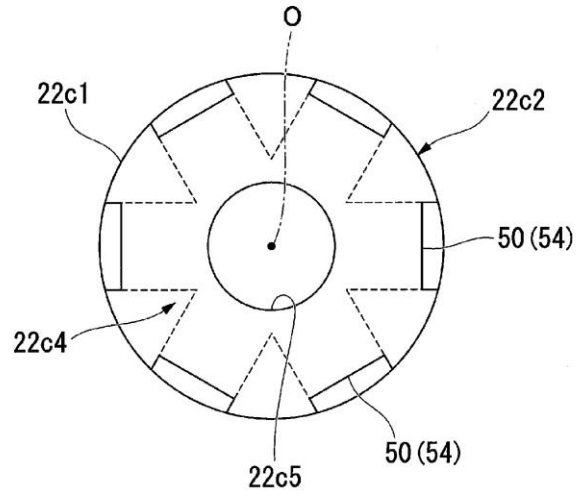
[図3]



[図4]



[図5]



- (11) No. 838
- (21) PA 838
- (22) 18/07/2022
- (30)
- (43) 27/02/2026
- (51) Int.C1.2018.01B 01J 21/00(2006.01), B 01J 21/02(2006.01), B 01J 37/08(2006.01), B 01J 35/02(2006.01), B 01J 37/04(2006.01), B 01J 35/00(2006.01) // (B 01J 21:00, 35:00 )
- (54) PHOTOCATALYTIC REACTOR CELL
- (57) The present, disclosure relates generally to reactor cells comprising an enclosure and one or more plasmonic photocatalysts on a catalyst support disposed within the enclosure. In some embodiments of the disclosure, the enclosure is at least partially optically transparent..
- (71) SYZYGY PLASMONICS INC.  
9000 Kirby Drive Houston, TX 77054, United States of America.
- (72) KHATIWADA, Suman and BEST, Trevor William.
- (74) Tilleke & Gibbins Lao Co., Ltd.
- (55)

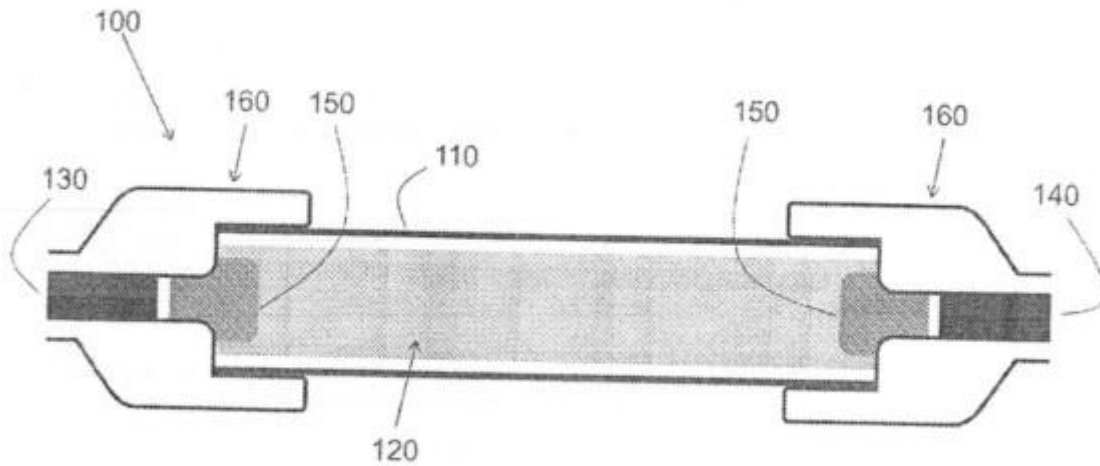


Figure 1A

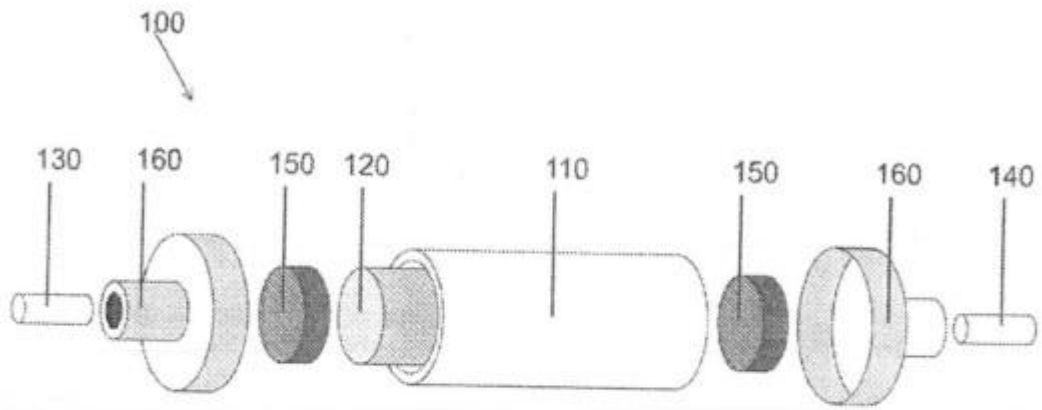


Figure 1B

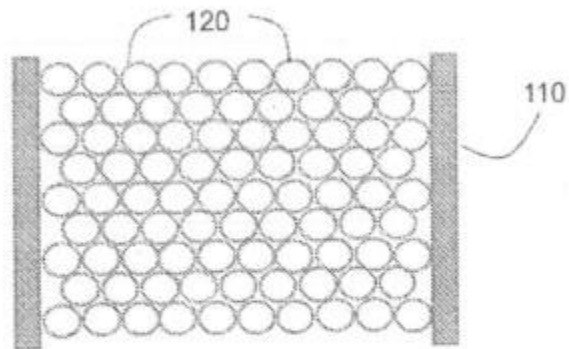
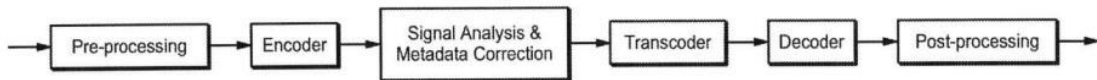


Figure 2

- (11) No. 908
- (21) PA 908
- (22) 23/08/2023
- (30) 202110294415.4 19/03/2021 CN
- (43) 27/03/2026
- (51) Int.Cl.2018.01C 08J 3/075(2006.01), C 08L 33/26(2006.01), A 61L 26/00(2006.01)
- (54) COMPOSITE POLYACRYLAMIDE HYDROGEL AND PREPARATION METHOD THEREFOR
- (57) ການປະດິດນີ້ໄດ້ເປີດເຜີຍສານປະກອບ ໂຟລີອາຄຣີລະໄມ ໄຮໂດຣເຈວ, ໃນພາກສ່ວນໂດຍນໍ້າໜັກປະກອບມີ ວັດຖຸດິບຕໍ່ໄປນີ້: 100 ສ່ວນຂອງ acrylamide, 0.2-1 ສ່ວນຂອງສານຕ້ານເຊື້ອແບັກທີເຣັຍ, 0.05-1 ສ່ວນຂອງສານຕ້ານເຊື້ອແບັກທີເຣັຍ, 0.05-1 ສ່ວນຂອງສານ cross-linking, 220-290 ສ່ວນຂອງ ນໍ້າ deionized, 0.1-0.5 ສ່ວນຂອງສານເລີ່ມຕົ້ນ (initiator), ແລະ 0.1-0.5 ສ່ວນຂອງສານ ກະຕຸ້ນ (catalyst); ທາດປະສົມ ໂຟລີອາຄຣີລະໄມ ໄຮໂດຣເຈວ ໄດ້ຖືກກະກຽມໂດຍຂຶ້ນຕອນດັ່ງຕໍ່ໄປນີ້: ການເພີ່ມນໍ້າ acrylamide ແລະ deionized ໄດ້ຖືກຕື່ມໃສ່ໃນໂຖທົດລອງແກ້ວກິ້ນມົນ, ສັ່ນ ແລະ ລະລາຍດ້ວຍອັດຕາຄວາມໄວ 60 r / ນາທີ, ຫຼັງຈາກນັ້ນ, ສານ cross-linking ໄດ້ຖືກເພີ່ມເຂົ້າໄປໃນ ເຕົາປະຕິກອນ, ຄວາມໄວໄດ້ເພີ່ມຂຶ້ນເປັນ 300-500 r / ນາທີ, ໂຖທົດລອງແກ້ວກິ້ນມົນໄດ້ຖືກວາງໄວ້ ໃນພາສະນະທີ່ມີນໍ້າກ້ອນ, ໄຮໂດຣເຈວຖືກເພີ່ມເຂົ້າເປັນເວລາ 5 ນາທີ, ດູດເຂົ້າໄປໃນສະແລງ ແລະ ເກັບຮັກສາໄວ້ໃນອຸນຫະພູມທີ່ 4°C ເປັນເວລາ 48 ຊົ່ວໂມງ ເພື່ອທີ່ຈະປ່ຽນເປັນຮູບແບບເປັນໄຮໂດຣເຈນ, ໄຮໂດເຈນໄດ້ຖືກເກັບໄວ້ໃນນໍ້າກ້ອນ ແລະ ຝອກ ເປັນເວລາ 48 ຊົ່ວໂມງ, ແລະ ນໍ້າໄດ້ຖືກປ່ຽນທຸກໆ 12 ຊົ່ວໂມງ ເພື່ອໃຫ້ໄດ້ ທາດປະສົມໂຟລີອາຄຣີລະໄມ ໄຮໂດຣເຈວ. ທາດປະສົມໂຟລີອາຄຣີລະໄມ ໄຮໂດຣເຈວມີຄຸນສົມບັດກົນຈັກສູງ ແລະ ຄຸນນະພາບຕ້ານເຊື້ອແບັກທີເຣຍ ແລະ ມີມູນຄ່າການນໍາໃຊ້ທີ່ຍິ່ງໃຫຍ່ ໃນຂົງເຂດທາງການແພດ..
- (71) HENGYANG JIANHENG INDUSTRIAL CO., LTD  
No. 8, Shangni Road, Songmu Economic Development Zone Hengyang, Hunan 421000,  
China.
- (72) LIU, Xiaofei.
- (74) HAVIP (LAOS) INTELLECTUAL PROPERTY LAW SOLE CO., LTD.
- (55)

- (11) No. 917
- (21) PA 917
- (22) 12/09/2023
- (30) SG10201604643R 15/01/2014 SG
- (43) 24/04/2026
- (51) Int.Cl.2018.01G 01L 19/16(2006.01), G 10L 19/06(2013.01), G 10L 19/002(2013.01)
- (54) ເຄື່ອງເຂົ້າລະຫັດ ແລະ ຖອດລະຫັດສຽງຜ່ອມກັບໂປຣແກຣມຄວາມດັງຂອງສຽງ ແລະ ຂອບເຂດຂອງຂໍ້ມູນແບບເມຕ້າ (ຂໍ້ມູນເມຕາ)
- (57) ເຄື່ອງມື ແລະ ວິທີການສ້າງກະແສຂໍ້ມູນບິດສຽງທີ່ເຂົ້າລະຫັດລວມທັງການລວມຂໍ້ມູນເມຕາຂອງ ຄວາມດັງໂປຣແກຣມ ແລະ ຂໍ້ມູນສຽງໃນກະແສຂໍ້ມູນບິດ ແລະ ອາດຈະລວມເຖິງຂໍ້ມູນເມຕາຂອບເຂດໂປຣແກຣມໃນຢ່າງໜ້ອຍໜຶ່ງສ່ວນ (ເຊັ່ນ: ຂອບເຂດ) ຂອງກະແສຂໍ້ມູນບິດ. ລັກສະນະອື່ນໆ ຄືອຸປະກອນ ແລະ ວິທີການຖອດລະຫັດກະແສຂໍ້ມູນບິດດັ່ງກ່າວເຊັ່ນ: ລວມທັງການດຳເນີນການປະມວນຜົນຄວາມດັງແບບທີ່ສາມາດປັບຂອງຂໍ້ມູນສຽງຂອງໂປຣແກຣມສຽງທີ່ລະບຸໂດຍກະແສຂໍ້ມູນບິດ ຫຼື ການຮັບຮອງຄວາມຖືກຕ້ອງແລະ/ຫຼື ການກວດສອບຄວາມຖືກຕ້ອງຂອງຂໍ້ມູນເມຕາ ແລະ/ຫຼື ຂໍ້ມູນສຽງດັ່ງກ່າວ. ໂປຣແກຣມສຽງອີກລັກສະນະໜຶ່ງຄືໜ່ວຍປະມວນຜົນສຽງ (ເຊັ່ນ: ຕົວເຂົ້າລະຫັດ ຫຼື ຕົວປະມວນຜົນຫຼັກ) ທີ່ກຳນົດຄ່າ (ເຊັ່ນ: ໂປຣແກມໄວ້) ເພື່ອດຳເນີນການຮູບແບບອື່ນໆຂອງວິທີການ ຫຼື ລວມທັງໜ່ວຍເກັບຄວາມຈຳເຊິ່ງຈັດເກັບຢ່າງໜ້ອຍໜຶ່ງຂອບເຂດຂອງກະແສຂໍ້ມູນບິດສຽງທີ່ສ້າງຂຶ້ນຕາມຮູບລັກສະນະໃດໜຶ່ງຂອງວິທີການ..
- (71) Dolby Laboratories Licensing Corporation  
1275 Market Street, San Francisco, California 94103, United States of America.
- (72) GRANT Michael - Australian ; NORCROSS Scott Gregory - Canadian; RIEDMILLER Jeffrey - American and WARD Michael - British.
- (74) ACTIP (LAO) IP CO., LTD..
- (55)



**FIG. 1**

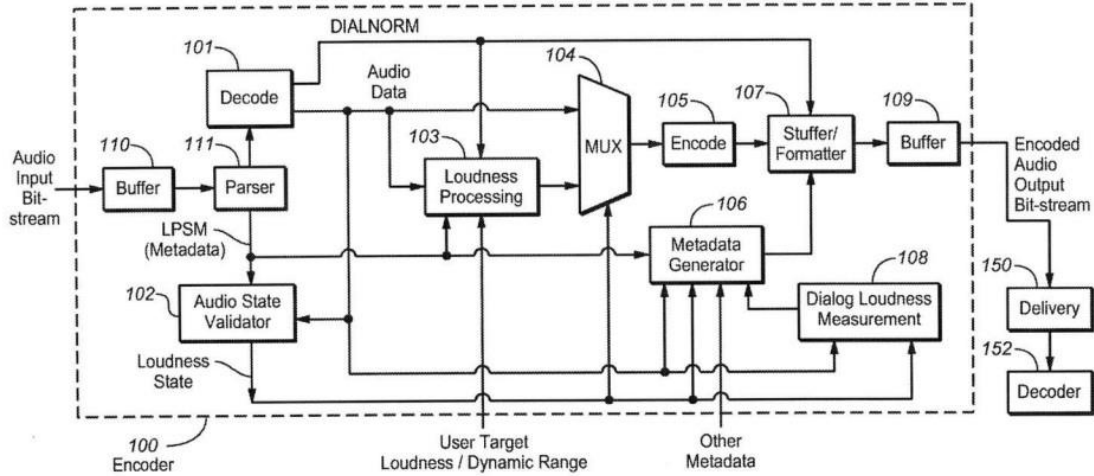


FIG. 2

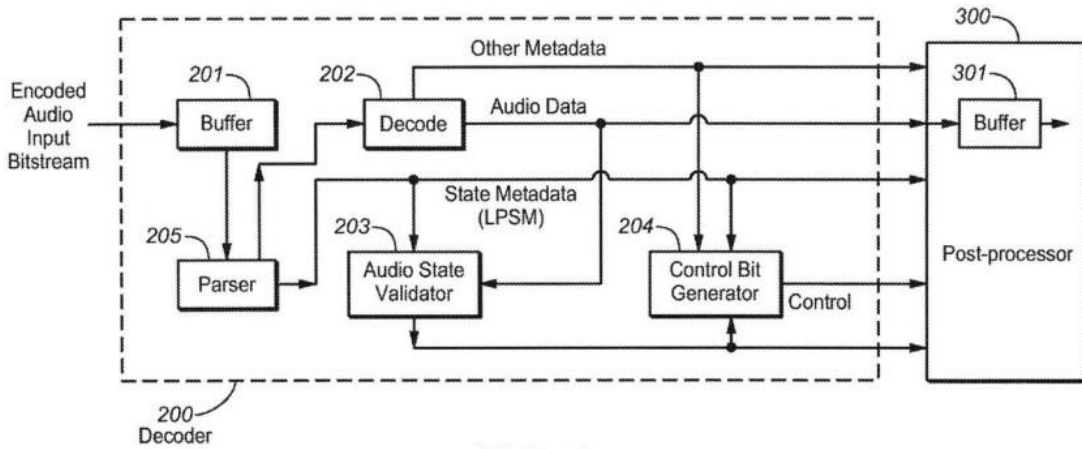


FIG. 3

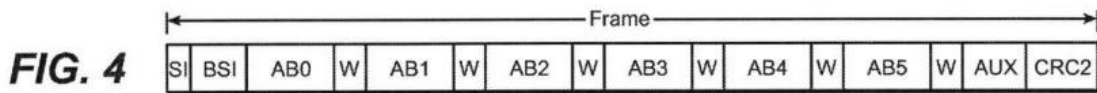


FIG. 4

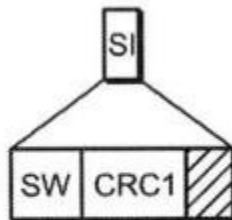
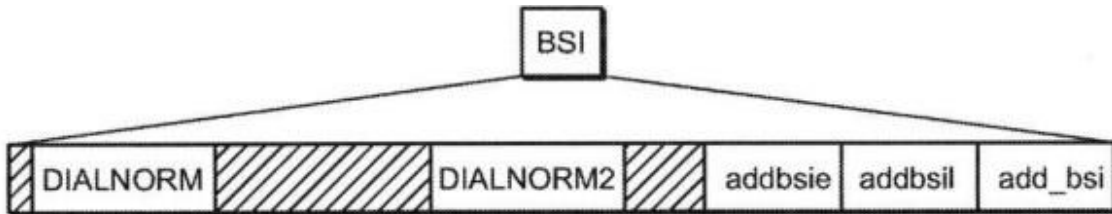
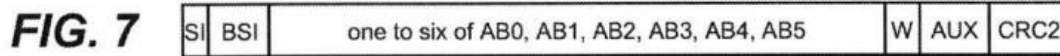


FIG. 5



**FIG. 6**



**FIG. 7**

Frame #	0	1	2	3	4	5	6	7	8	9	10	11	12	13	14	15	
Frames to Boundary	-16	-15	-14	-13	-12	-11	-10	-9	-8	-7	-6	-5	-4	-3	-2	-1	B
Program Boundary Flag Contents	100011	0	0	0	0	0	0	0	10011	0	0	0	1011	0	111	0	B
Exist	1	0	0	0	0	0	0	0	1	0	0	0	1	0	1	0	B
Frame Counter	0001->16								001->8				01->4		1->2		B
Count UP (+) / Down (-)	1								1						1		B

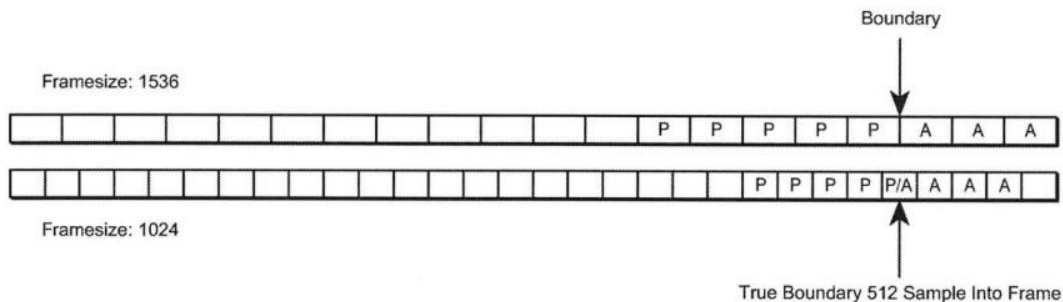
(Syntax of Program Boundary Flag Counting Down to Program Boundary)

**FIG. 8**

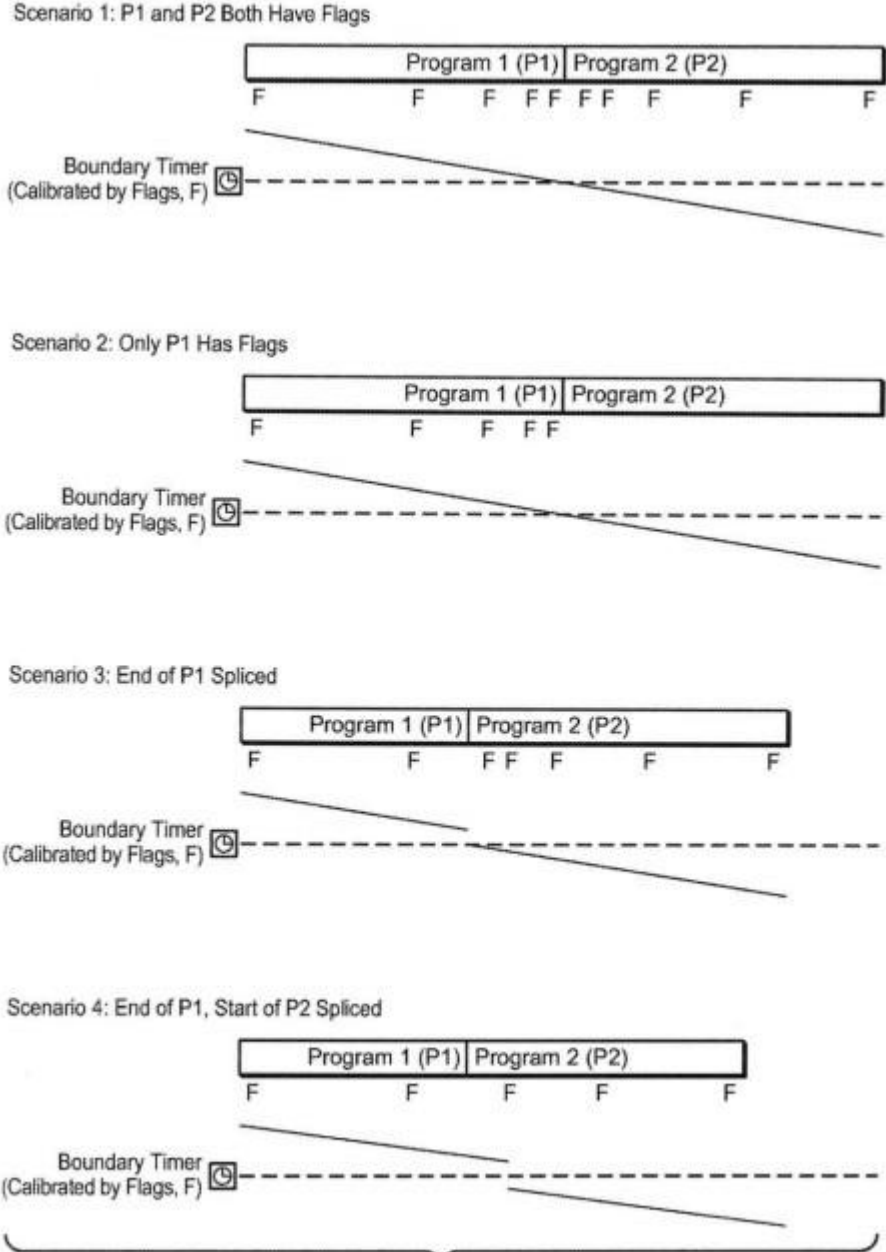
Frame #	B	0	1	2	3	4	5	6	7	8	9	10	11	12	13	14	15
Frames to Boundary	B	1	2	3	4	5	6	7	8	9	10	11	12	13	14	15	16
Program Boundary Flag Contents	B	0	110	0	1010	0	0	0	10010	0	0	0	0	0	0	0	10010
Exist	B	0	1	0	0	0	0	0	1	0	0	0	0	0	0	0	
Frame Counter	B	1->2		01->4			001->8								0001->16		
Count UP (+) / Down (-)	B	0		0					0								0

(Syntax of Program Boundary Flag Counting Up for Beginning of Program)

**FIG. 9**

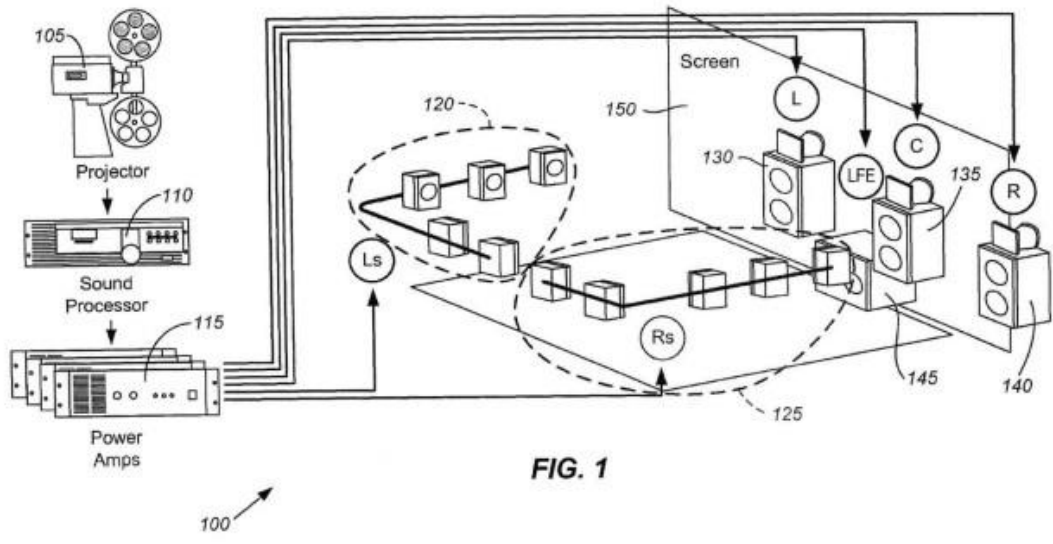


**FIG. 10**



**FIG. 11**

- (11) No. 918
- (21) PA 918
- (22) 12/09/2023
- (30) SG10201603678X 27/06/2012 SG
- (43) 10/04/2026
- (51) Int.Cl.2018.01H 04S 7/00(2006.01), H 04S 3/00(2006.01)
- (54) SYSTEM AND TOOLS FOR ENHANCED 3D AUDIO AUTHORING AND RENDERING
- (57) ເຄື່ອງມືທີ່ໄດ້ຮັບການພັດທະນາສໍາລັບການຂຽນ ແລະ ການສ້າງພາບຈາກແບບຈໍາລອງຂໍ້ມູນການຂະຫຍາຍສຽງ ແມ່ນໄດ້ຮັບການສະໜອງ. ບາງເຄື່ອງມືການຂຽນດັ່ງກ່າວນັ້ນຊ່ວຍສາມາດສະຫຼຸບຂໍ້ມູນການຂະຫຍາຍສຽງ ສໍາລັບສະພາບແວດລ້ອມການຂະຫຍາຍທີ່ຫຼາກຫຼາຍ. ຂໍ້ມູນການສ້າງສຽງອາດຖືກຂຽນຂຶ້ນໂດຍການສ້າງຂໍ້ມູນ ເມຕາສໍາລັບວັດຖຸສຽງ. ຂໍ້ມູນເມຕາອາດຖືກສ້າງຂຶ້ນໂດຍອີງຕາມຂອບເຂດຂອງລໍາໂພງ. ໃນລະຫວ່າງຂະບວນ ການສ້າງພາບຈາກແບບຈໍາລອງ, ຂໍ້ມູນການຂະຫຍາຍສຽງອາດຈະຖືກໃໝ່ຕາມໂຄງຮ່າງລໍາໂພງຂອງສະພາບ ແວດລ້ອມຂອງການຂະຫຍາຍສຽງສະເພາະ..
- (71) Dolby Laboratories Licensing Corporation  
1275 Market Street, San Francisco, California 94103, United States of America.
- (72) TSINGOS, Nicolas R. - American; ROBINSON, Charles Q. - American and SCHARPF, Jurgen W. - American.
- (74) ACTIP (LAO) IP CO., LTD..
- (55)



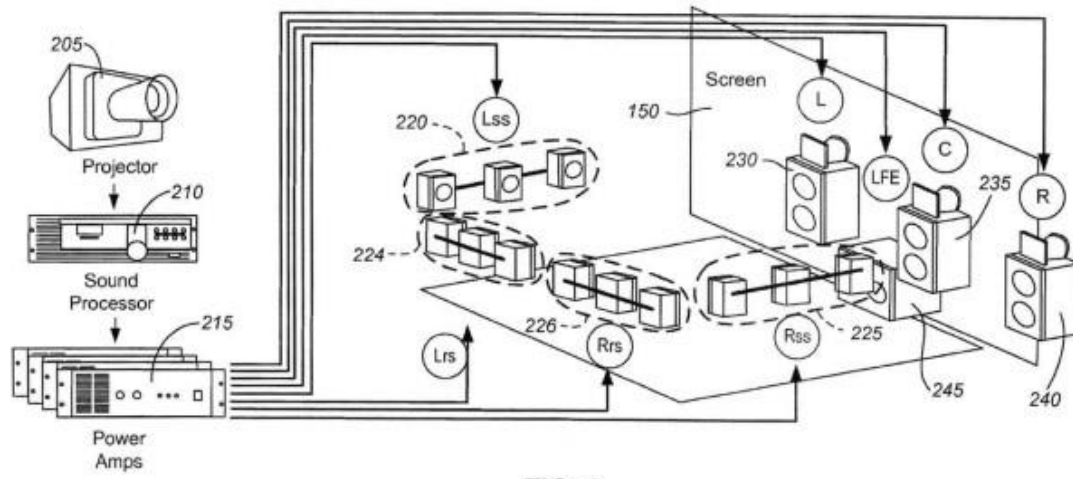
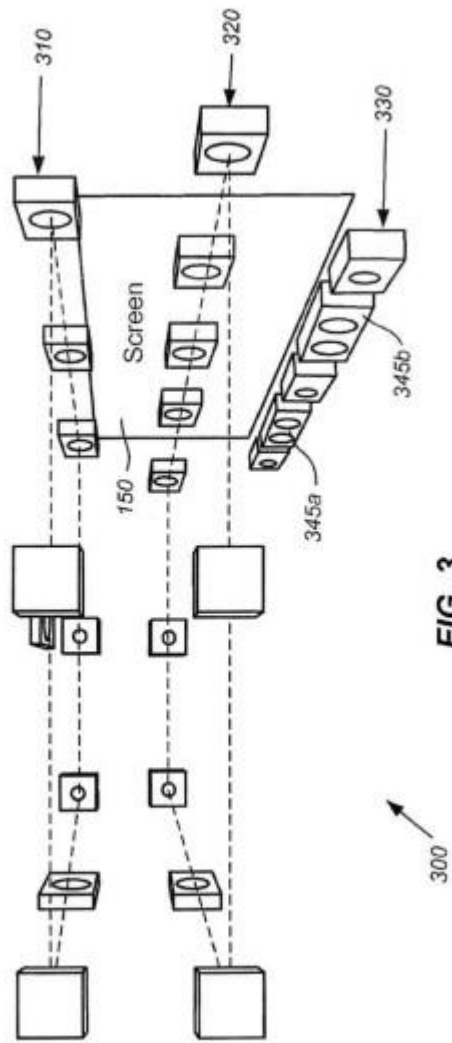
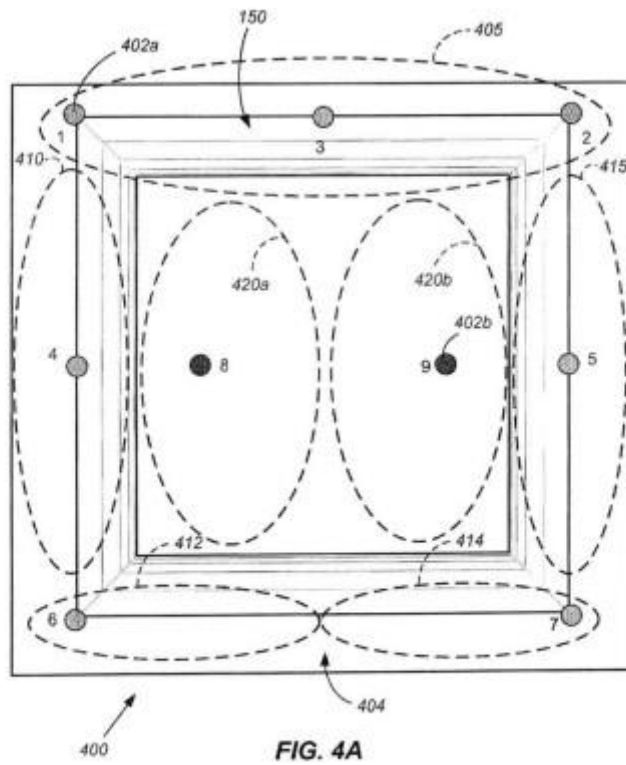


FIG. 2

200 ↗





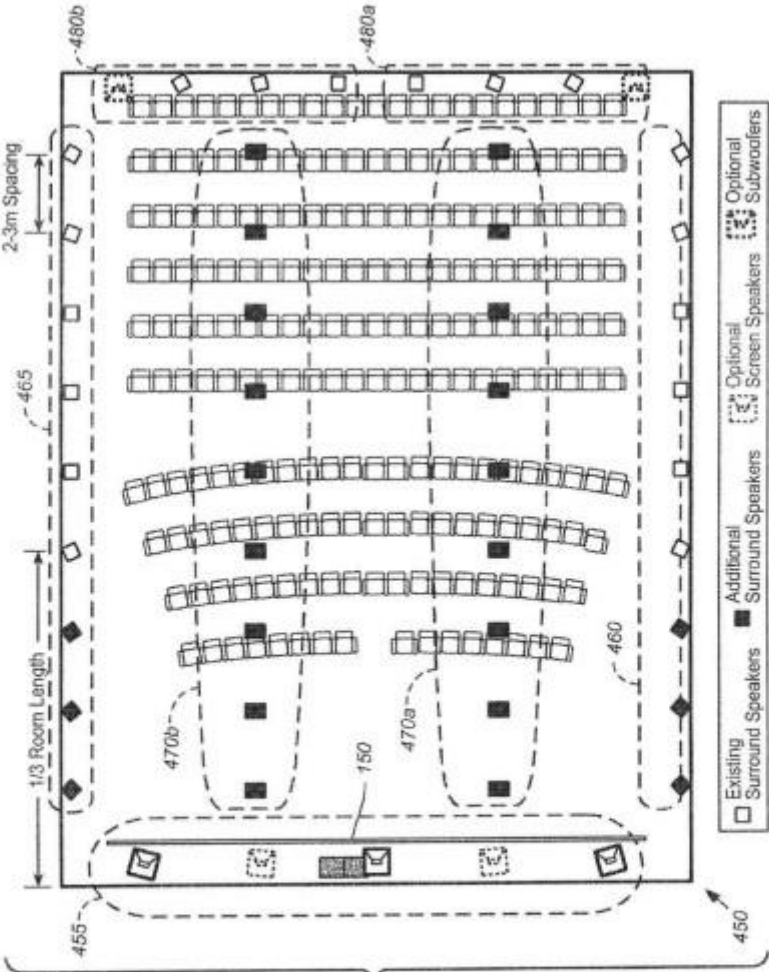
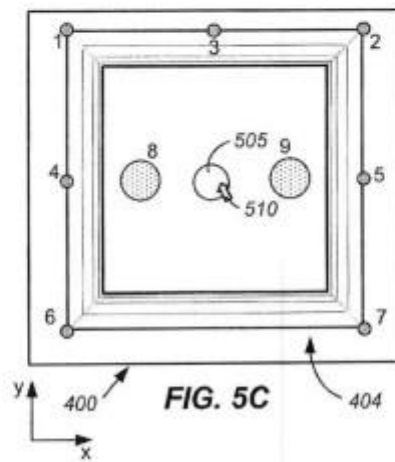
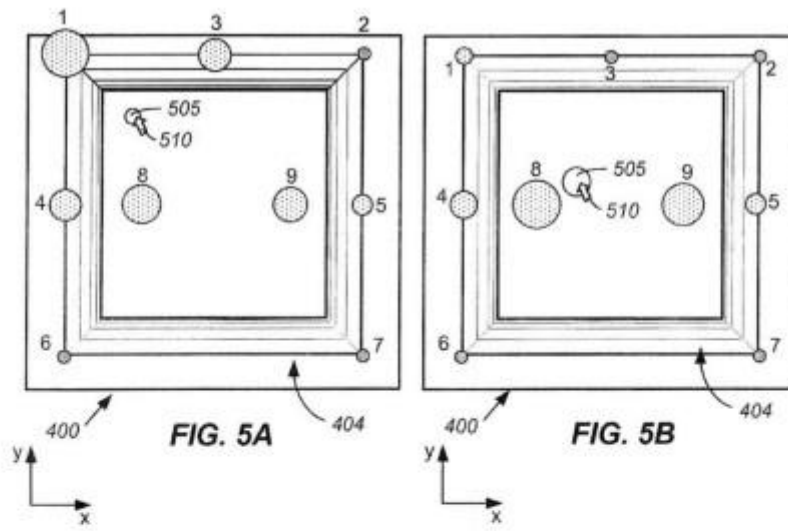
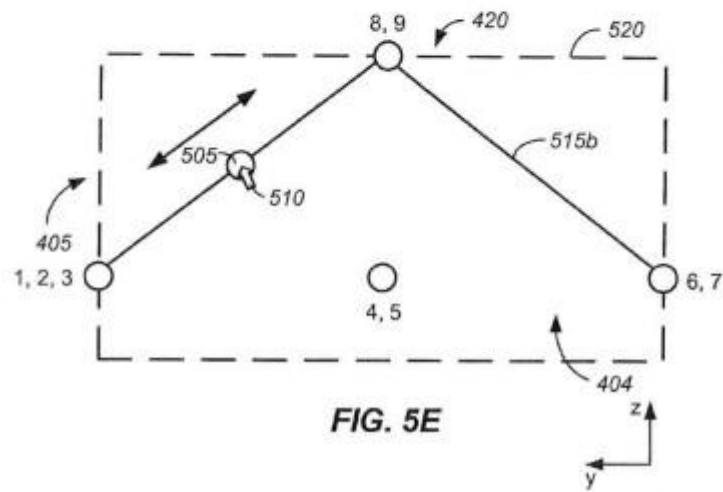
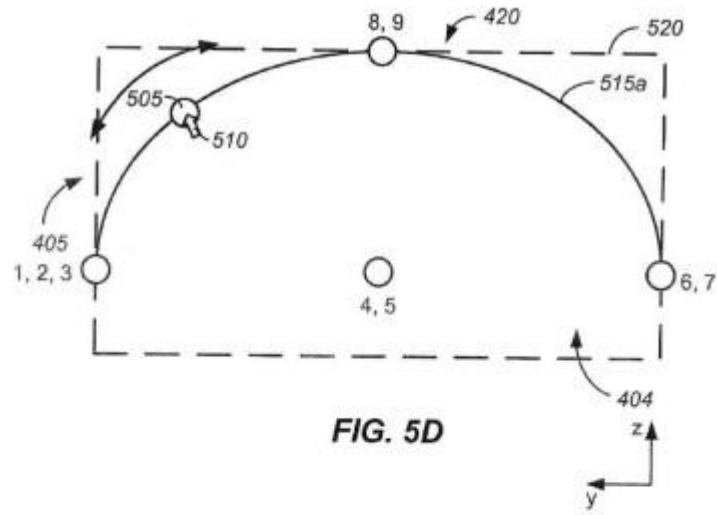


FIG. 4B





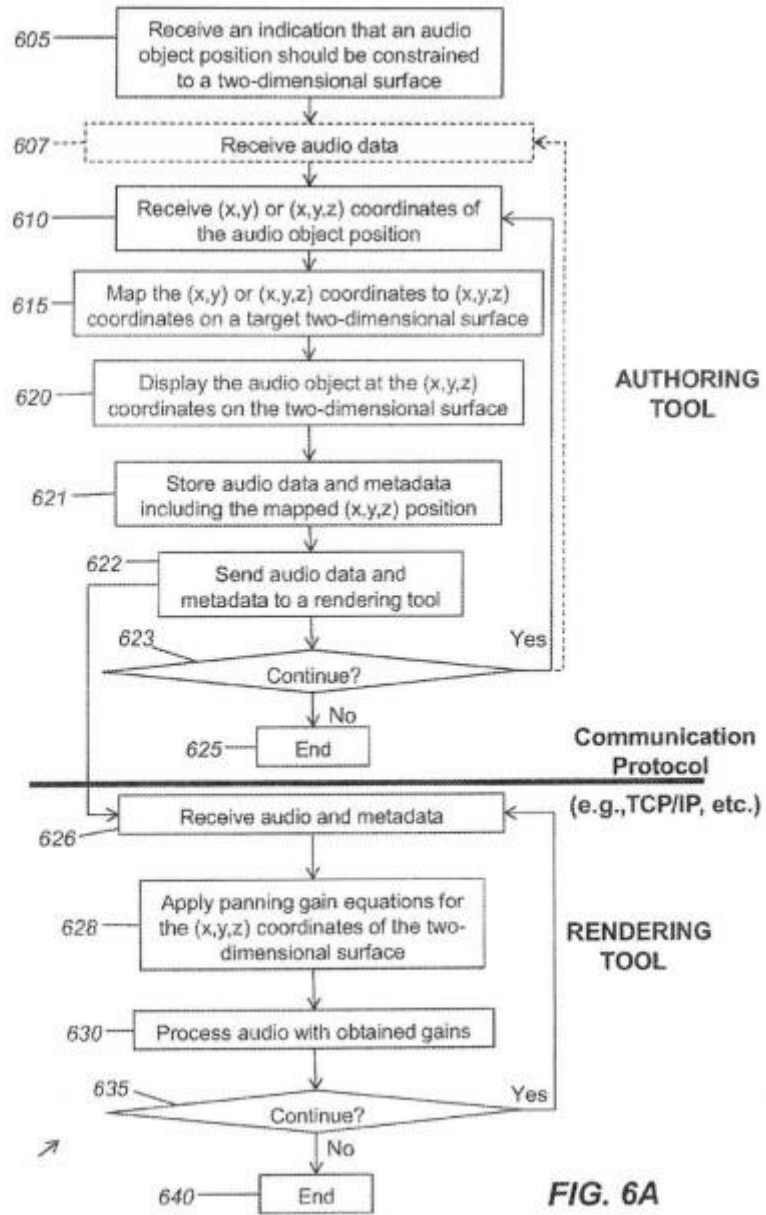


FIG. 6A

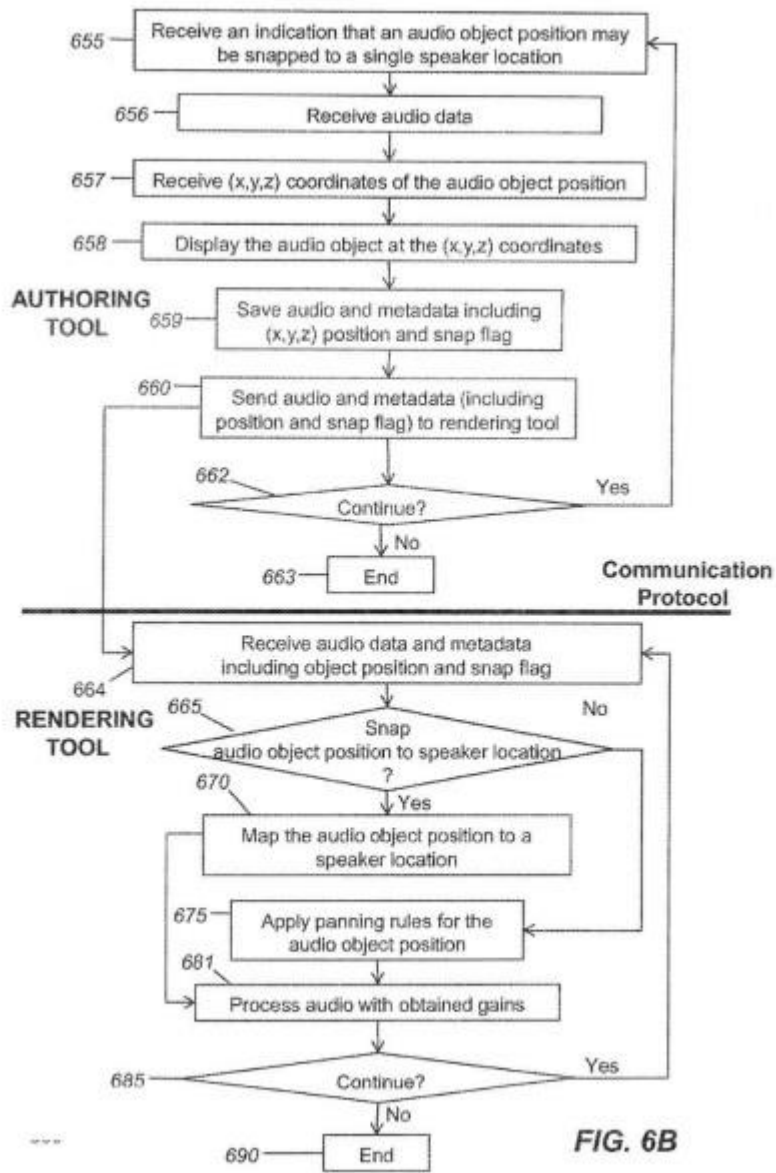
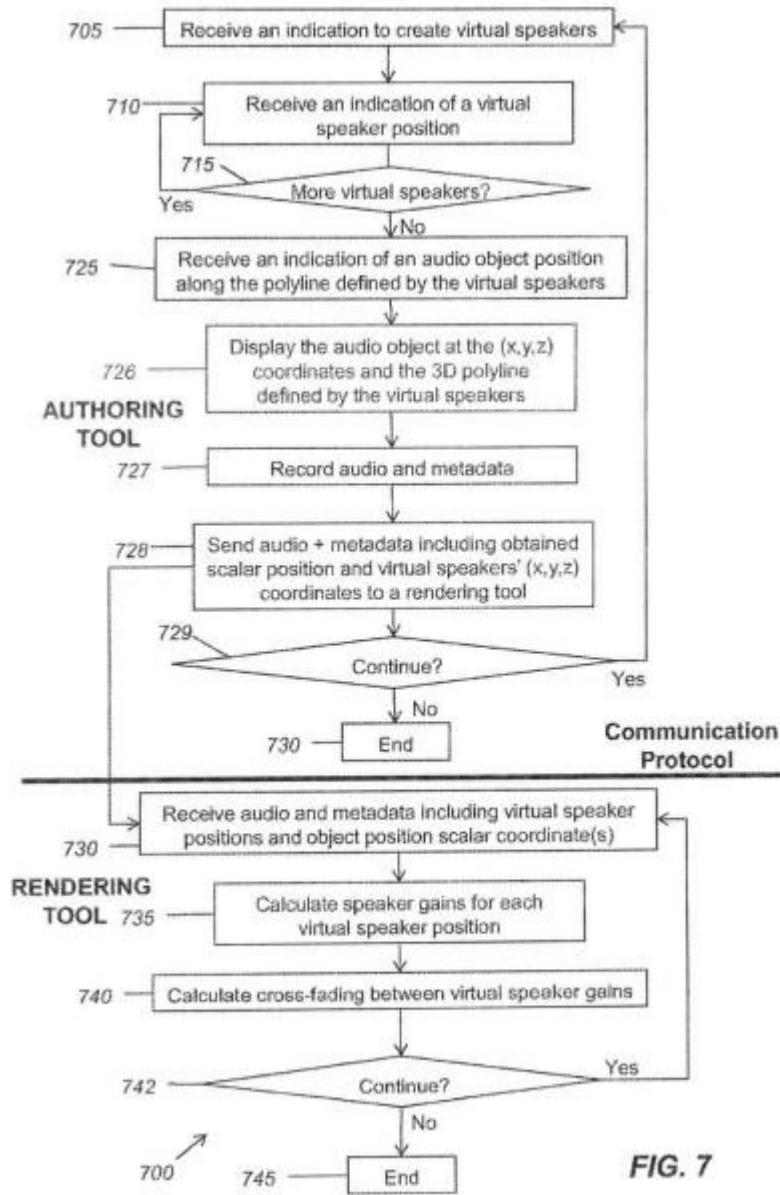
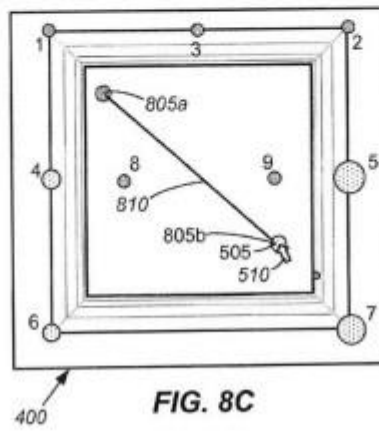
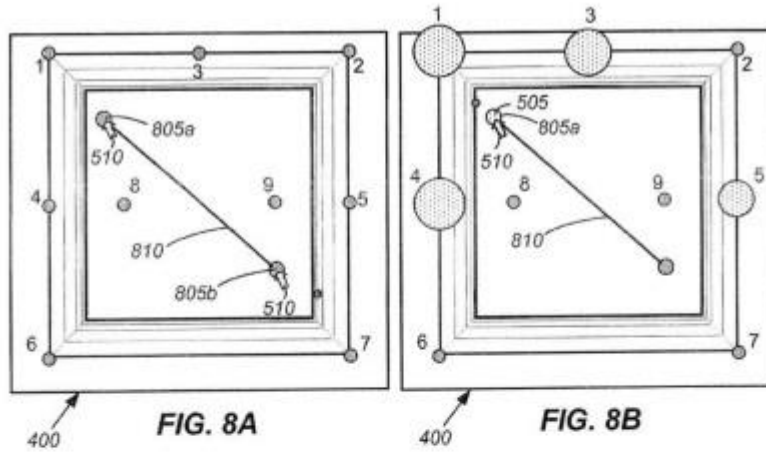
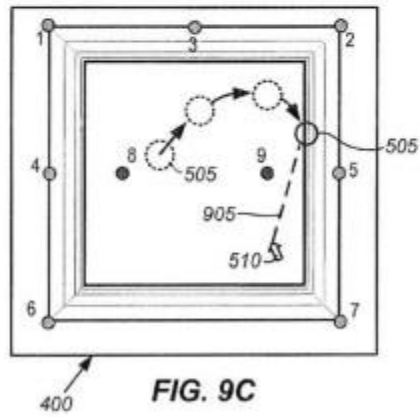
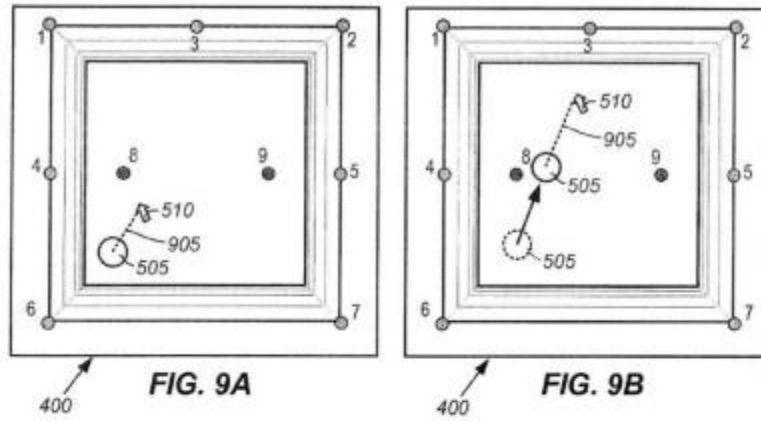


FIG. 6B







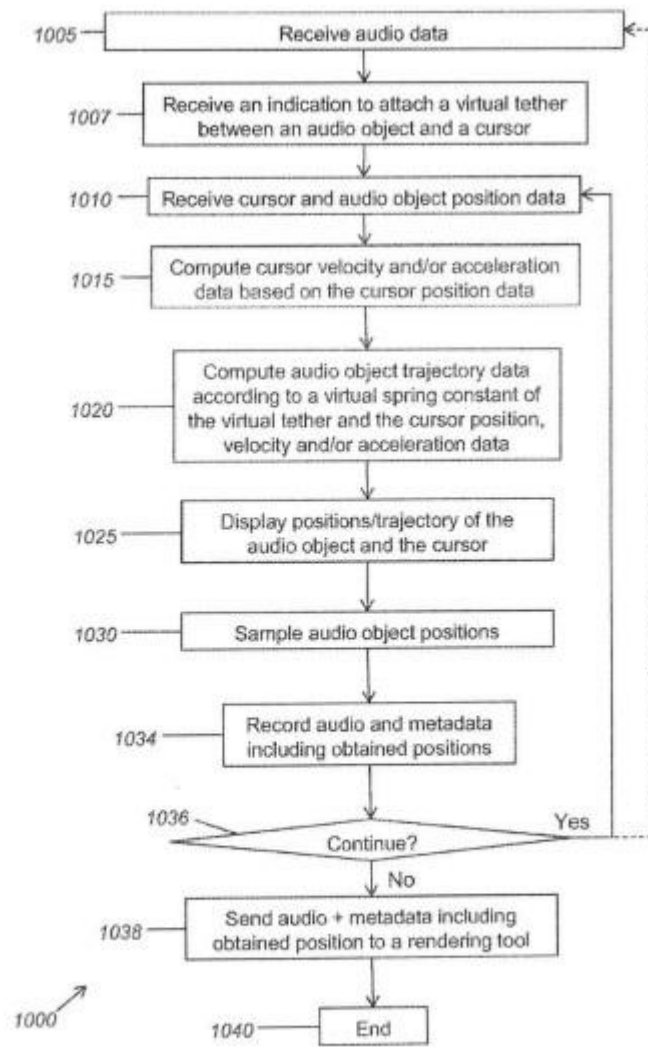


FIG. 10A

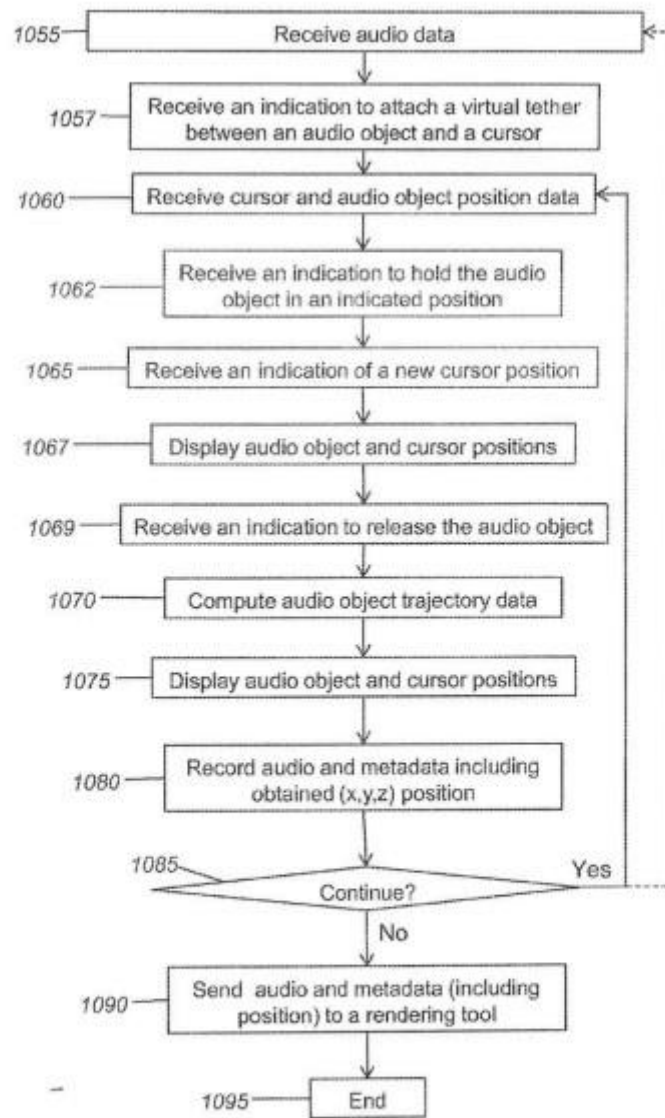
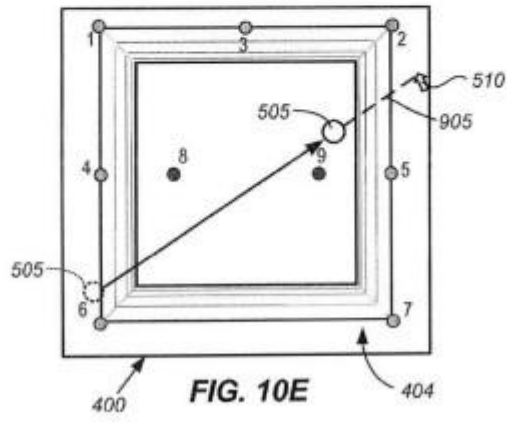
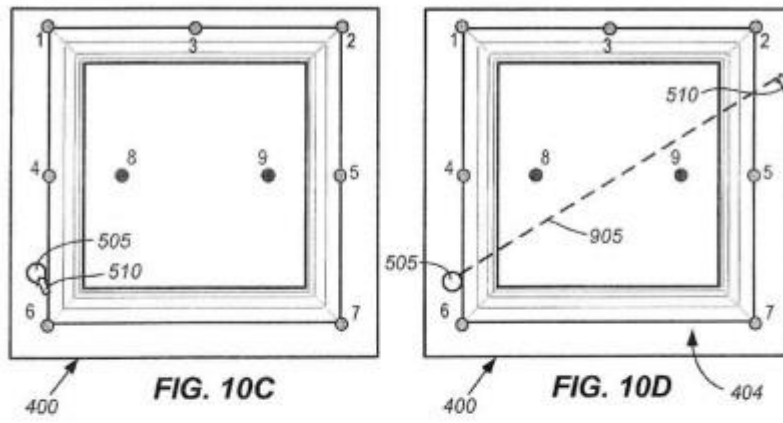
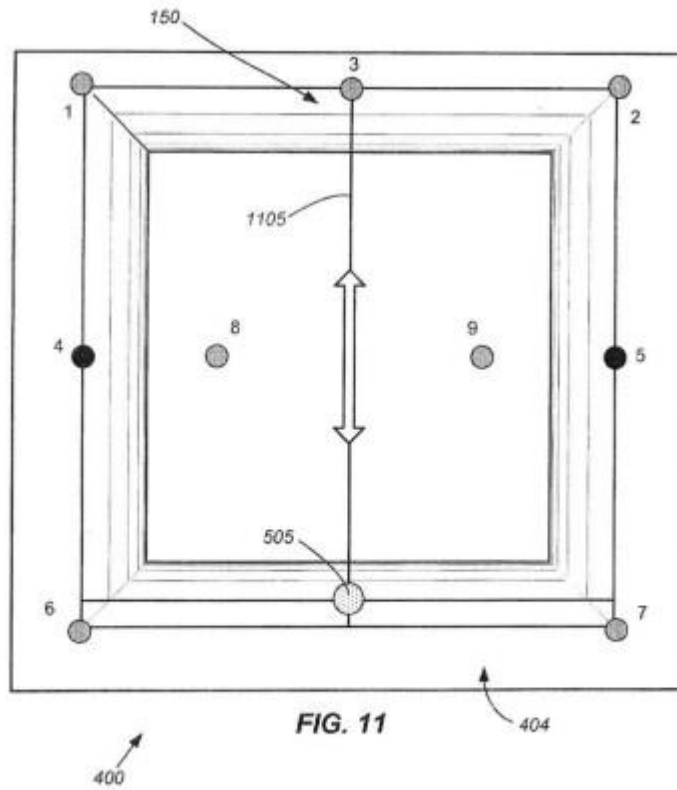


FIG. 10B





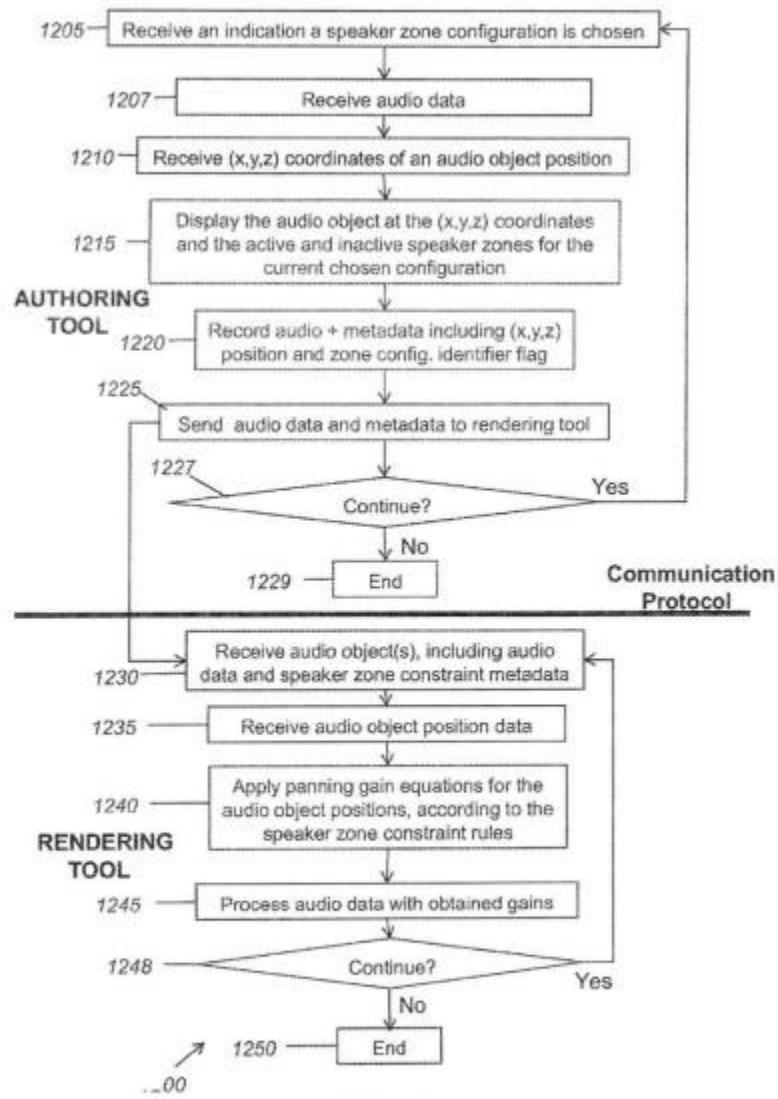
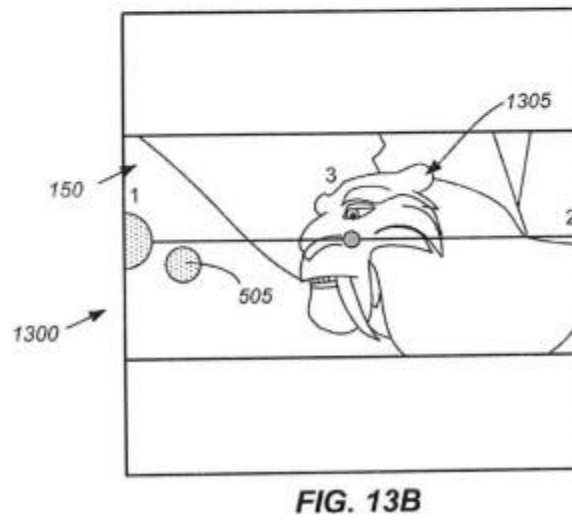
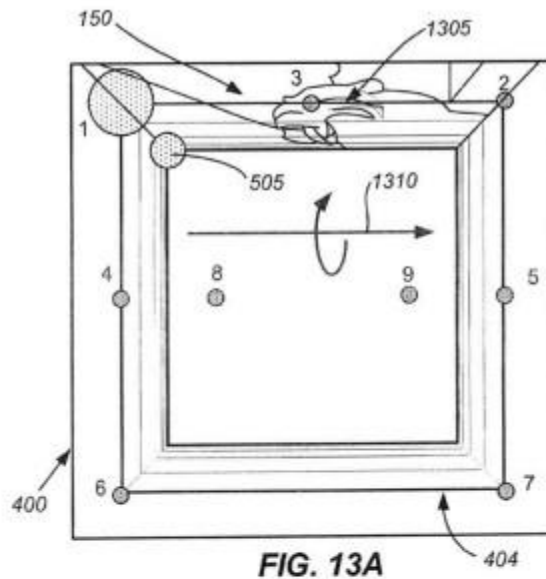
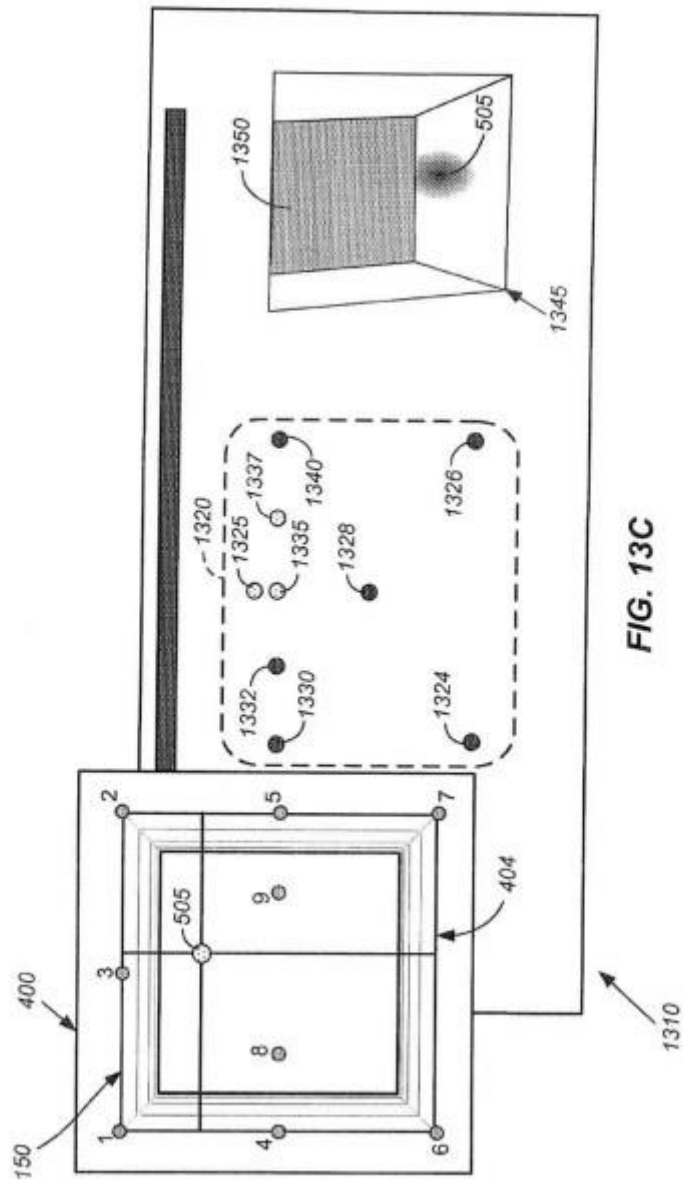


FIG. 12





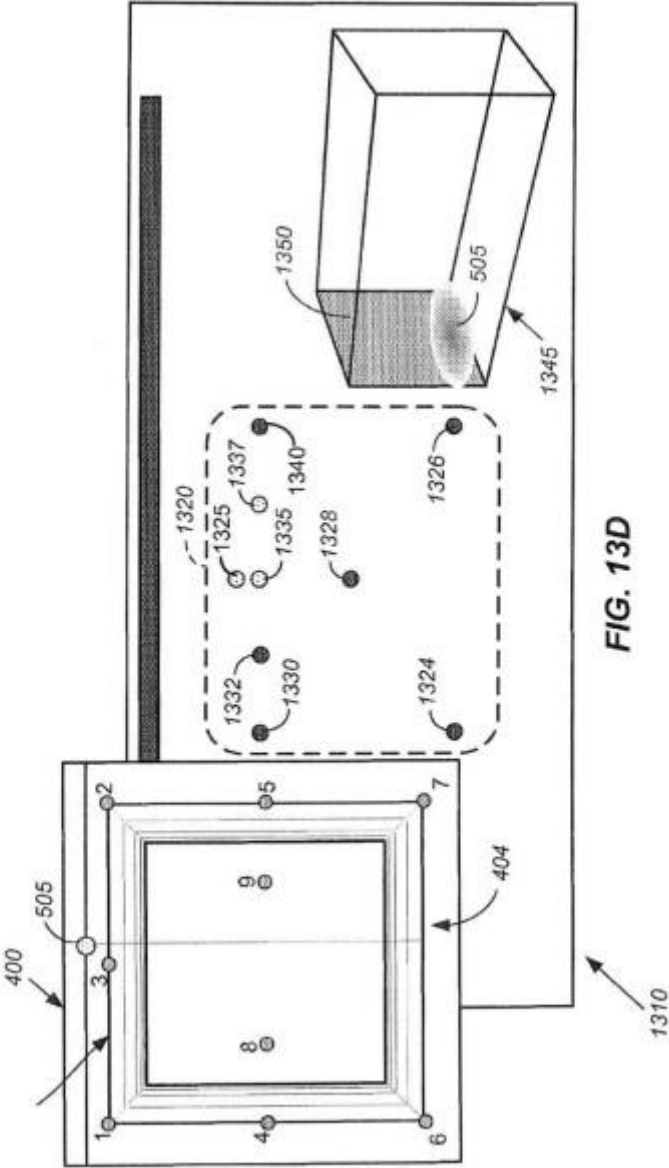
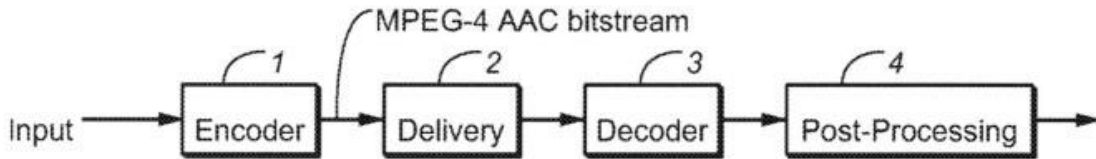
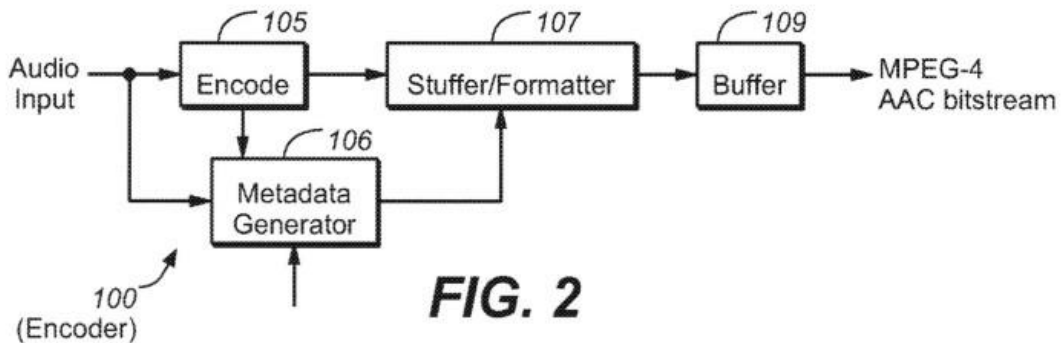


FIG. 13D

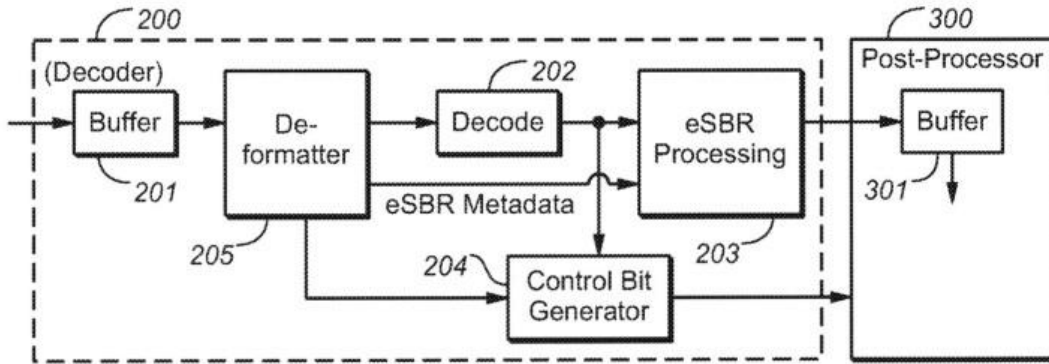
- (11) No. 979
- (21) PA 979
- (22) 23/10/2024
- (30) 11201707459S 10/03/2016 SG
- (43)
- (51) Int.Cl.2018.01G 01L 21/04(2006.01), H 03G 3/00(2006.01), G 10L 19/025(2013.01)
- (54) ການຖອດລະຫັດບິດສະຕຣີມສຽງດ້ວຍຂໍ້ມູນເມຕ້າໃນການຈຳລອງແຖບສະເປັກຕຣັມທີ່ໄດ້ຮັບການປັບປຸງໃນອົງປະກອບຂອງຕົ້ມຂໍ້ມູນຢ່າງໜ້ອຍໜຶ່ງອົງປະກອບ
- (57) ຮູບລັກສະນະທີ່ກ່ຽວຂ້ອງກັບຫົວໜ່ວຍປະມວນຜົນສຽງທີ່ປະກອບມີບັດຟີຟີ ຕົວປ່ຽນຮູບແບບການບັນຈຸບິດສະຕຣີມ ແລະ ລະບົບຍ່ອຍການຖອກລະຫັດ. ບັດຟີຟີໃນການຈັດເກັບບິດສະຕຣີມສຽງທີ່ເຂົ້າລະຫັດໄວ້ຢ່າງໜ້ອຍໜຶ່ງບລັອກ. ໂດຍບລັອກແມ່ນປະກອບມີອົງປະກອບໃນການຕົ້ມ ທີ່ຂຶ້ນຕົ້ນດ້ວຍຕົວລະບຸທີ່ຕິດຕາມດ້ວຍຂໍ້ມູນຂອງການຕົ້ມ. ຂໍ້ມູນໃນການຕົ້ມປະກອບດ້ວຍແຟລັກຢ່າງໜ້ອຍໜຶ່ງແຟລັກທີ່ລະບຸວ່າການປັບປຸງການຈຳລອງແຖບສະເປັກຕຣັມ (eSBR) ແບບປັບປຸງເຊິ່ງຈະດຳເນີນການປະມວນຜົນກັບເນື້ອຫາສຽງຂອງບລັອກ. ນອກຈາກນີ້ ຍັງມີວິທີການທີ່ສອດຄ່ອງກັນ ສຳລັບການຖອດລະຫັດບິດສະຕຣີມສຽງທີ່ເຂົ້າລະຫັດ..
- (71) Dolby International AB  
77 Sir John Rogerson's Quay, Block, Grand Canal Docklands, Dublin D02 VK60, Republic of Ireland, Ireland.
- (72) VILLEMOS Lars - Swedish; EKSTRAND Per - Swedish and PURNHAGEN Heiko - Swedish.
- (74) ACTIP (LAO) IP CO, LTD..
- (55)



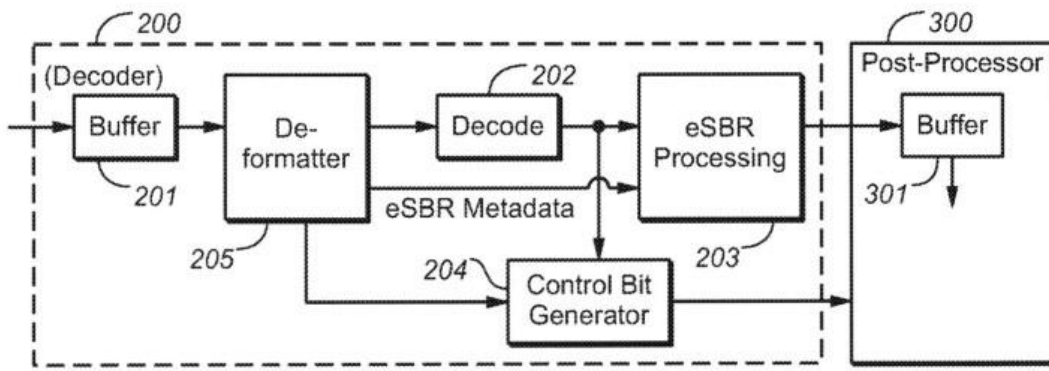
**FIG. 1**



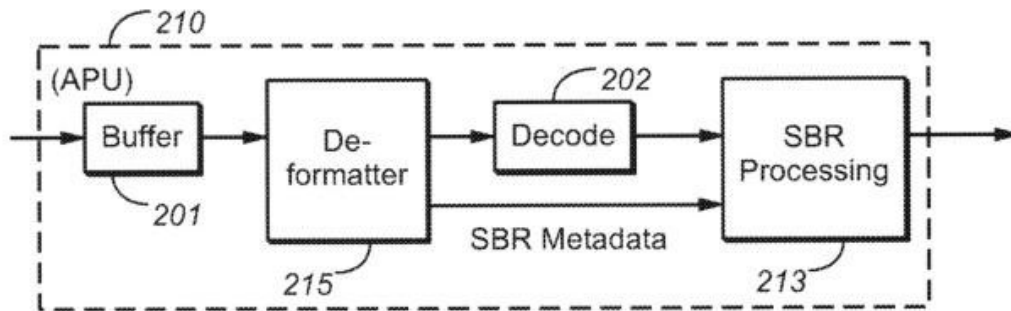
**FIG. 2**



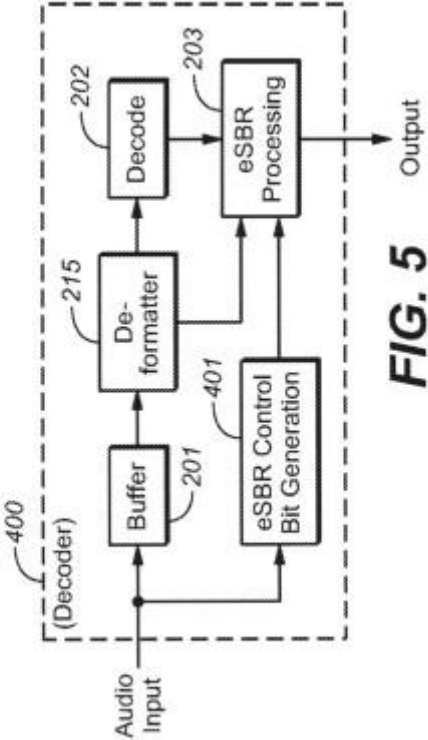
**FIG. 3**



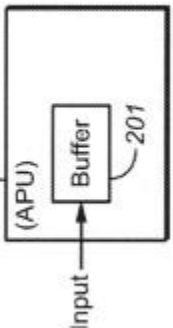
**FIG. 3**



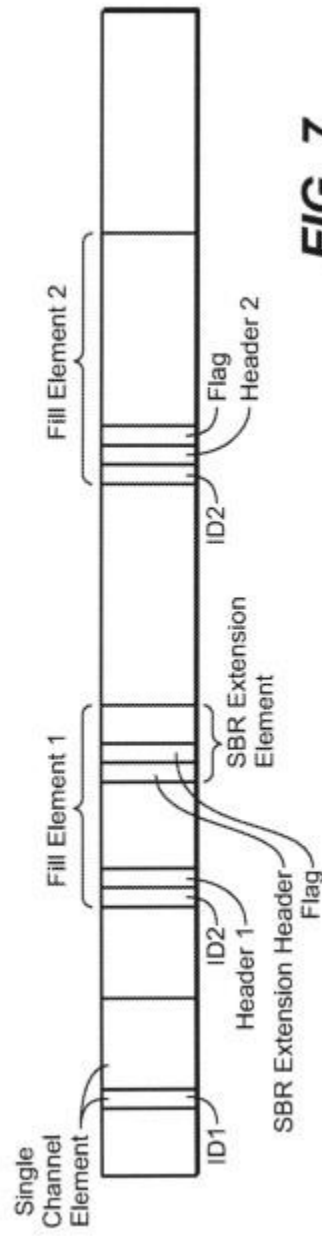
**FIG. 4**



**FIG. 5**

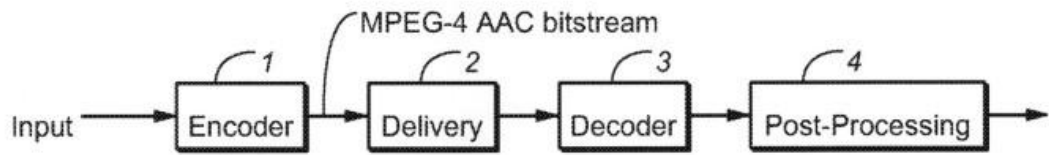


**FIG. 6**

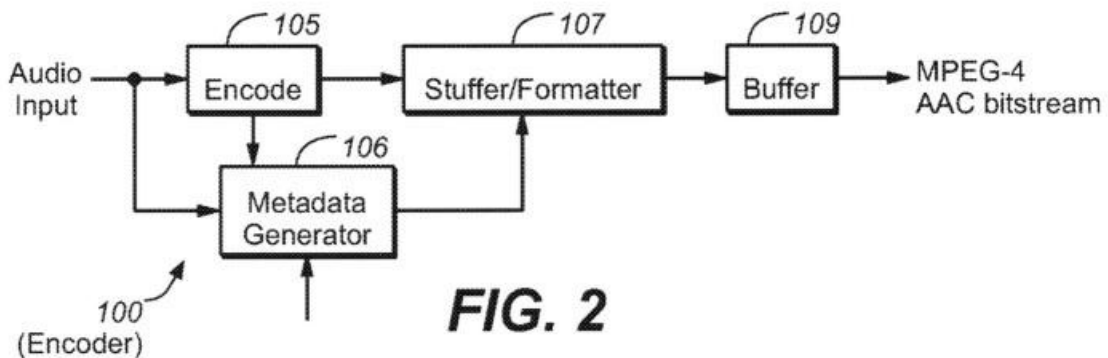


**FIG. 7**

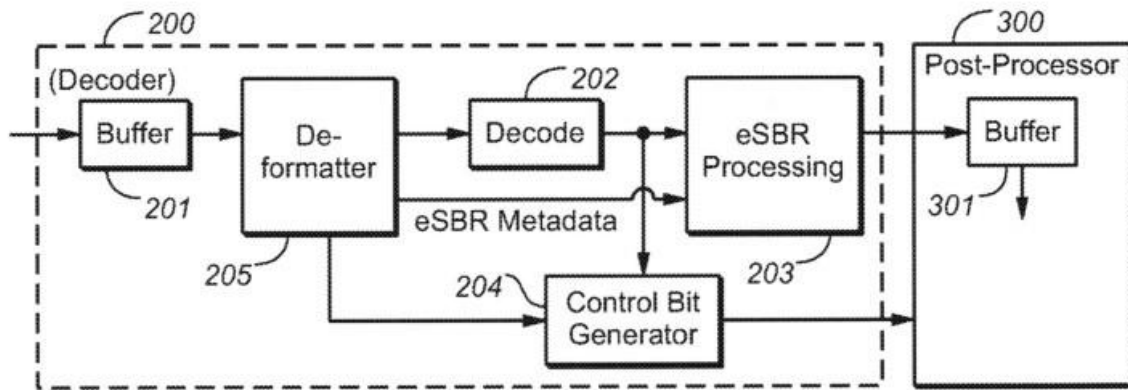
- (11) No. 980
- (21) PA 980
- (22) 23/10/2024
- (30) 10201802002Q 10/03/2016 SG
- (43)
- (51) Int.Cl.2018.01G 01L 21/04(2006.01), H 03G 3/00(2006.01)
- (54) ການຖອດລະຫັດບິດສະຕຣີມສຽງດ້ວຍຂໍ້ມູນເມຕ້າໃນການຈຳລອງແຖບສະເປັກຕຣັມ ທີ່ໄດ້ຮັບການປັບປຸງໃນອົງປະກອບຂອງຕື່ມຂໍ້ມູນຢ່າງໜ້ອຍໜຶ່ງອົງປະກອບ
- (57) ຮູບລັກສະນະທີ່ກ່ຽວຂ້ອງກັບຫົວໜ່ວຍປະມວນຜົນສຽງທີ່ປະກອບມີບັຟເຜີ້ ຕົວປ່ຽນຮູບແບບການບັນຈຸບິດສະຕຣີມ ແລະ ລະບົບຍ່ອຍການຖອກລະຫັດ. ບັຟເຜີ້ໃນການຈັດເກັບບິດສະຕຣີມສຽງທີ່ເຂົ້າລະຫັດໄວ້ຢ່າງໜ້ອຍໜຶ່ງບລັອກ. ໂດຍບລັອກແມ່ນປະກອບມີອົງປະກອບໃນການຕື່ມ ທີ່ຂຶ້ນຕົ້ນດ້ວຍຕົວລະບຸທີ່ຕິດຕາມດ້ວຍຂໍ້ມູນຂອງການຕື່ມ. ຂໍ້ມູນໃນການຕື່ມປະກອບດ້ວຍແຟລັກຢ່າງໜ້ອຍໜຶ່ງແຟລັກ ທີ່ລະບຸວ່າການປັບປຸງການຈຳລອງແຖບສະເປັນຕຣີມ (eSBR) ແບບປັບປຸງເຊິ່ງຈະດຳເນີນການປະມວນຜົນກັບເນື້ອຫາສຽງຂອງບລັອກ. ນອກຈາກນີ້ ຍັງມີວິທີການທີ່ສອດຄ່ອງກັນ ສຳລັບການຖອດລະຫັດບິດສະຕຣີມສຽງທີ່ເຂົ້າລະຫັດ..
- (71) Dolby International AB  
77 Sir John Rogerson's Quay, Block C, Grand Canal Docklands, Dublin D02 VK6O, Republic of Ireland, Ireland.
- (72) VILLEMOS Lars - Swedish; PURNHAGEN Heiko - Swedish and EKSTRAND Per - Swedish.
- (74) ACTIP (LAO) IP CO., LTD.
- (55)



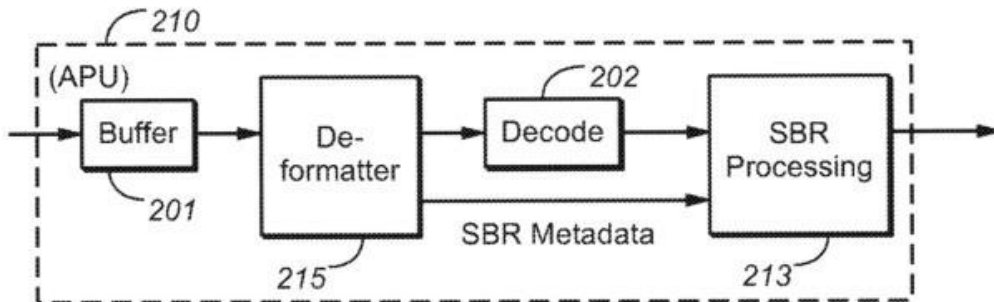
**FIG. 1**



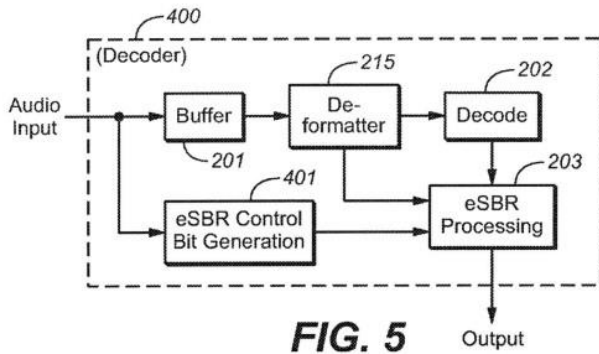
**FIG. 2**



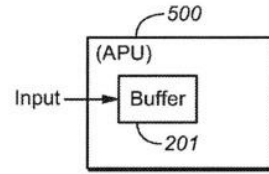
**FIG. 3**



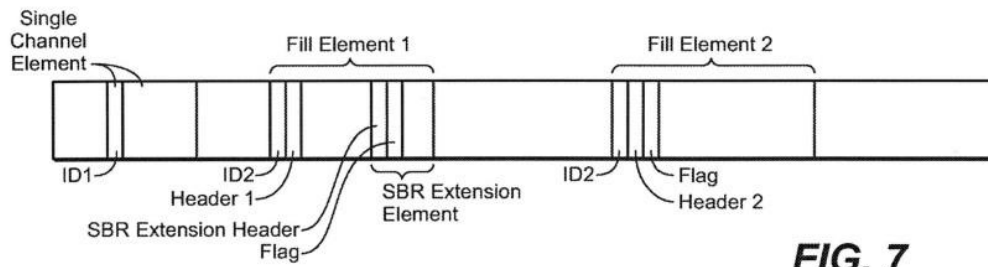
**FIG. 4**



**FIG. 5**



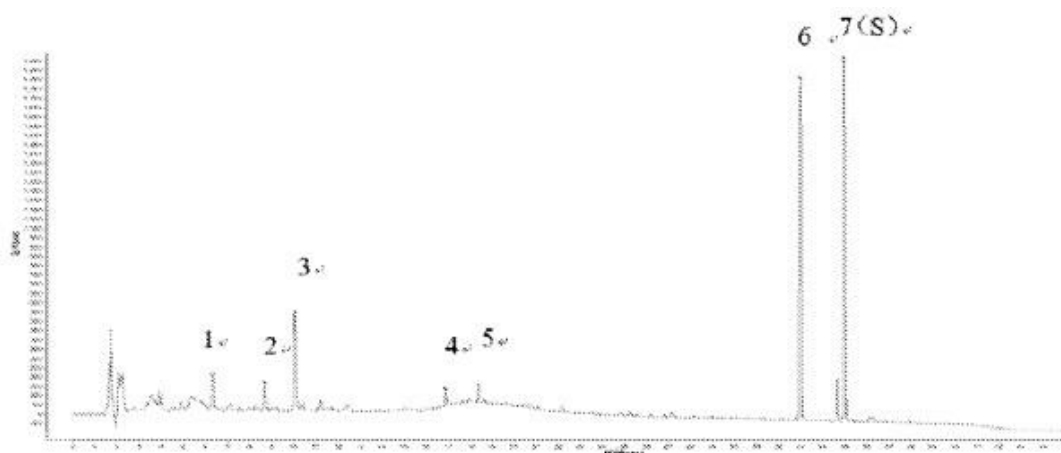
**FIG. 6**



**FIG. 7**

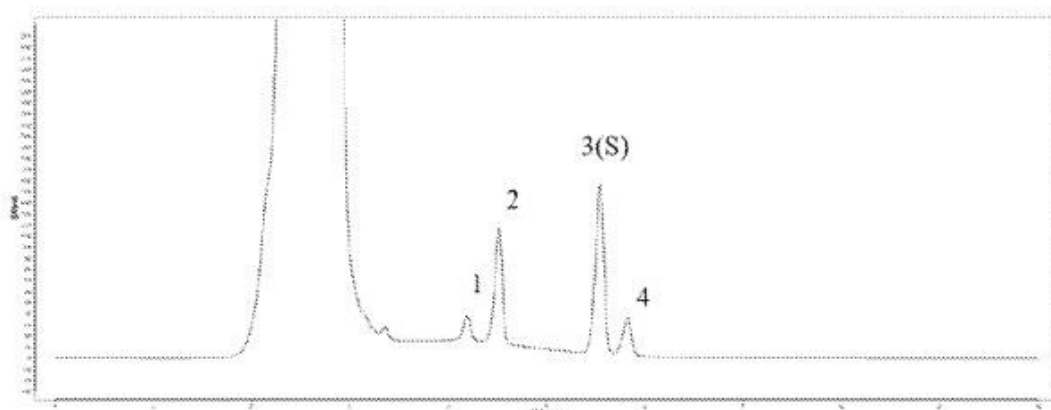
Official Gazette of Industrial Property Vol. 359, 05/06/2026

- (11) No. 1004
- (21) PA 1004
- (22) 14/03/2025
- (30) 202211145693.4 20/09/2022 CH
- (43)
- (51) Int.C1.2018.01G 01N 30/02(2006.01), G 01N 30/86(2006.01), A 61K 36/9068(2006.01), A 61K 33/06(2006.01), A 61P 31/16(2006.01), A 61P 11/00(2006.01), A 61P 31/14(2006.01)
- (54) TRADITIONAL CHINESE MEDICIN EXTRACT, MEDICAMENT, AND DETECTION METHOD THEREFOR
- (57) The disclosure relates to a Traditional Chinese Medicine extract, wherein, by weight ratio, the extract is made from the following ingredients: Magnoliae Officinalis Cortex 1-100 parts, Arecae Semen 1-100 parts, Amomum tsaoko Crevost & Lem. 1-100 parts, Ephedrae Herba 1-100 parts, Armeniacae Semen Amarum 1-100 parts, Notopterygii Rhizoma et Radix 1-100 parts, Zingiberis Rhizoma 1-100 parts, Pogostemonis Herba 1-100 parts, Eupatorium fortunei Turcz. 1-100 parts, Atractylodis Rhizoma 1-100 parts, Poria cocos 1-100 parts, Atractylodis Macrocephalae Rhizoma 1-100 parts, Gypsum Fibrosum 1-100 parts, Crataegi Fructus 1-100 parts, Massa Medicata Fermentata 1-100 parts, Hordei Fructus Germinatus 1-100 parts, Pheretima 1-100 parts, Vincetoxicum pycnostelma Kitag. 1-100 parts, Dryopteridis Crassirhizomatis Rhizoma 1-100 parts, and Lepidium apetalum seeds 1-100 parts; wherein, the extract has an ephedrine content of 0.5-1.5 mg/g and a solid content transfer rate of 18-25%..
- (71) JIANGSU KANION PHARMACEUTICAL CO., LTD  
Jiangning Industrial City, Economic and Technological Development Zone, Lianyungang, Jiangsu, China.
- (72) XIAO, Wei; ZHOU, EEnli; YU, Guifang; HU, Hanfei; WANG, Tuanjie; ZHANG, Chenfeng; CAO, Liang; WANG, Zhenzhong; LIU, Lina; LI, Liang and YAN, Ming.
- (74) Ageless Lao Sole Co., Ltd..
- (55)



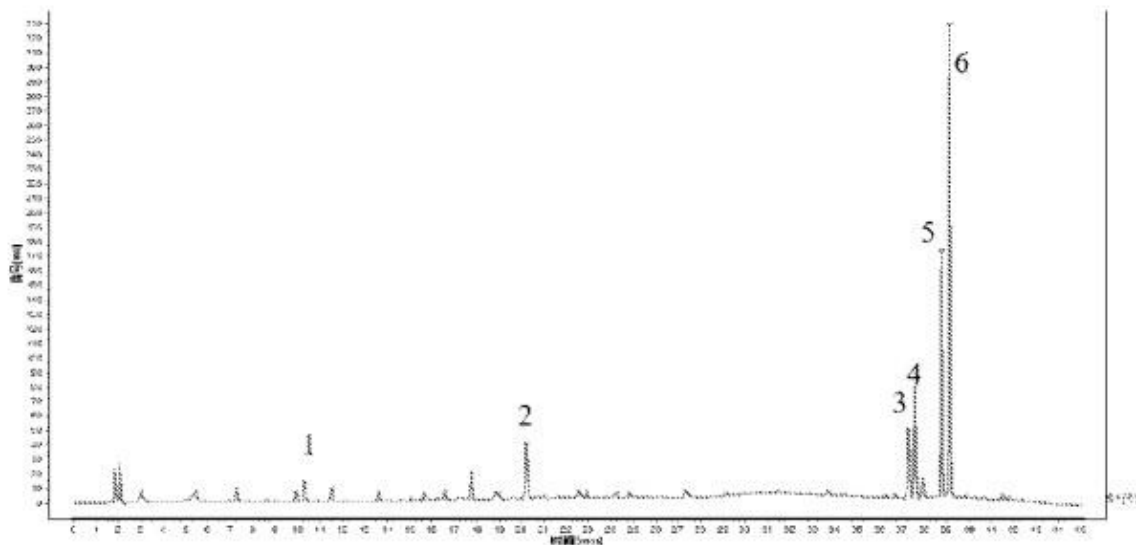
峰6: 和厚朴酚 峰7(S): 厚朴酚

图 1



峰1: 槟榔次碱 峰3(S): 槟榔碱

图 2



峰1: 原儿茶酸

图 3

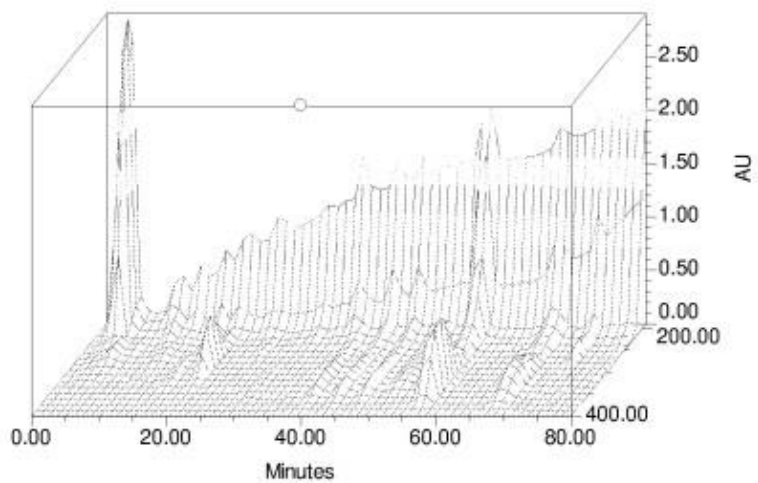


图 4

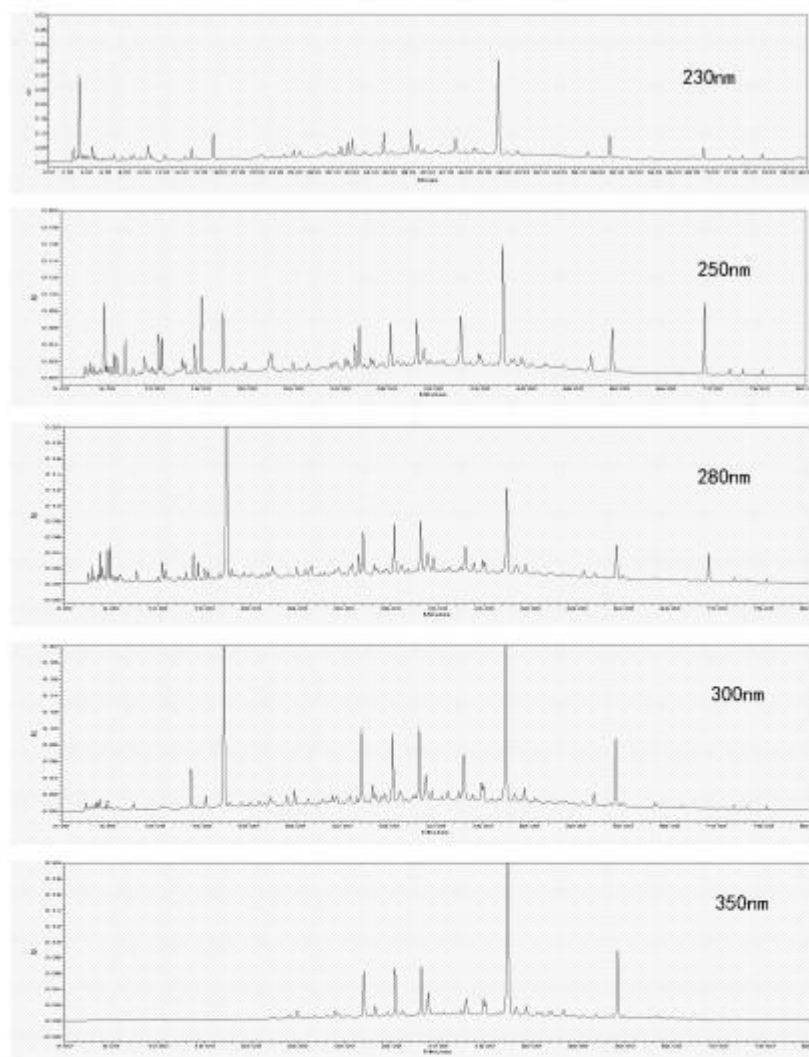
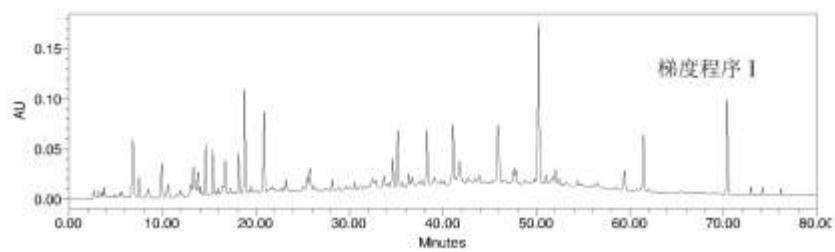


图 5



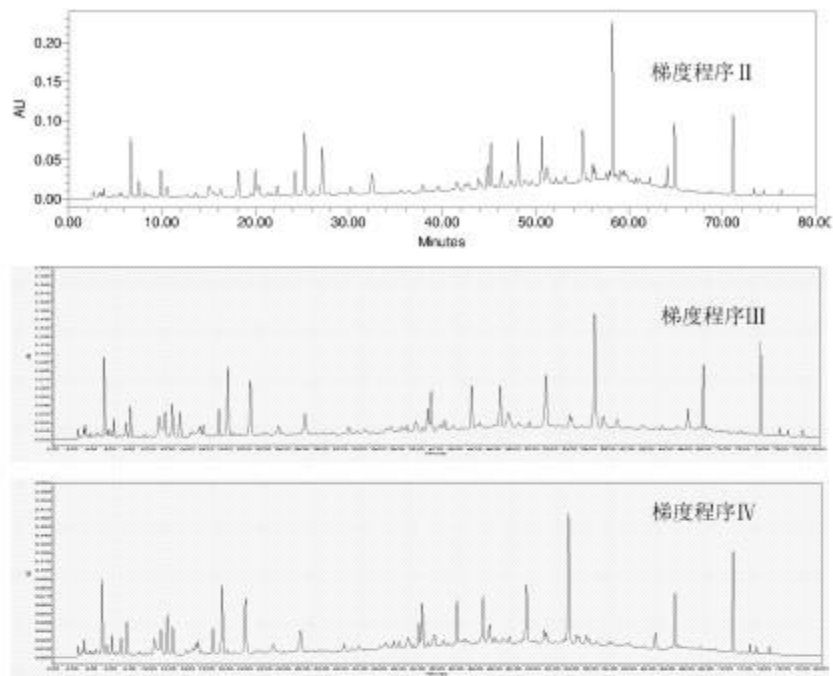
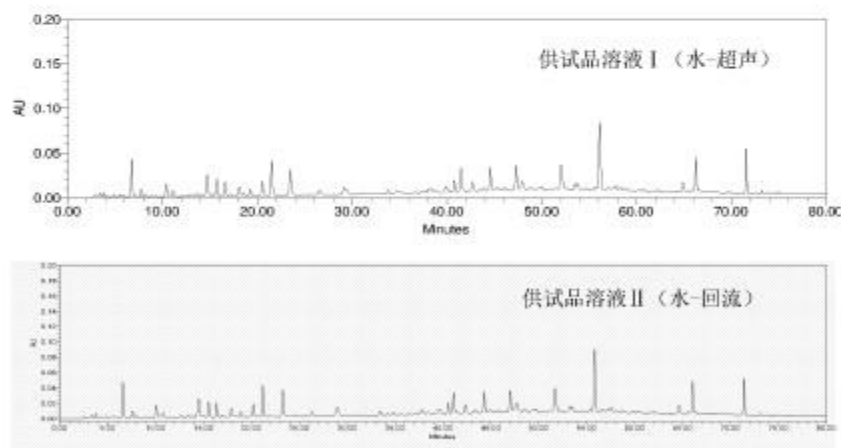


图 6



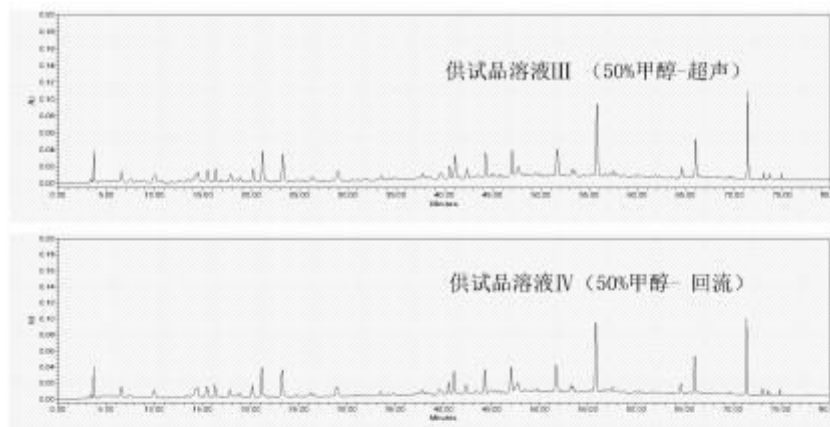
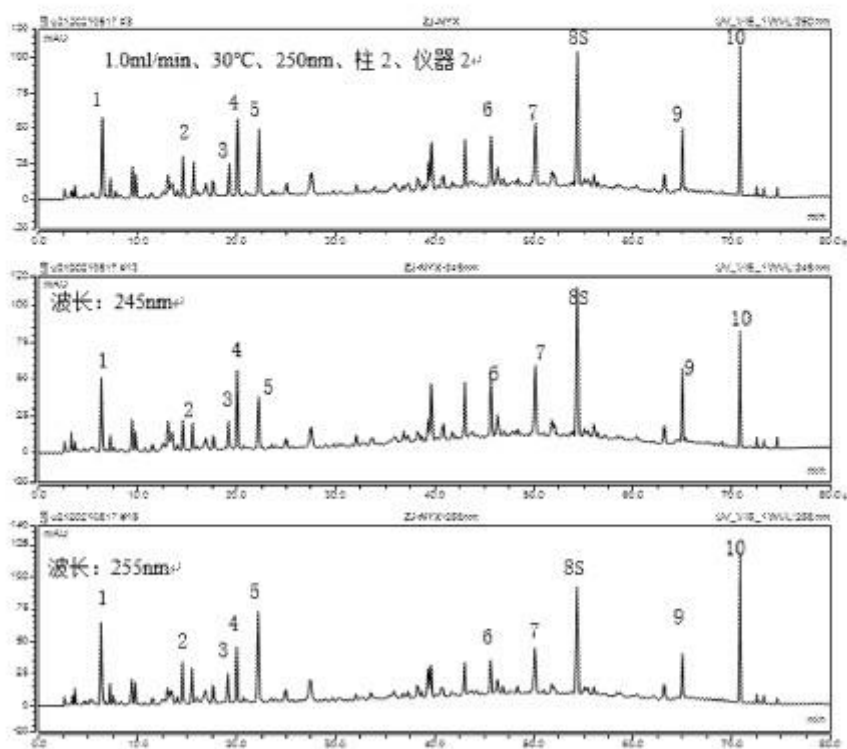
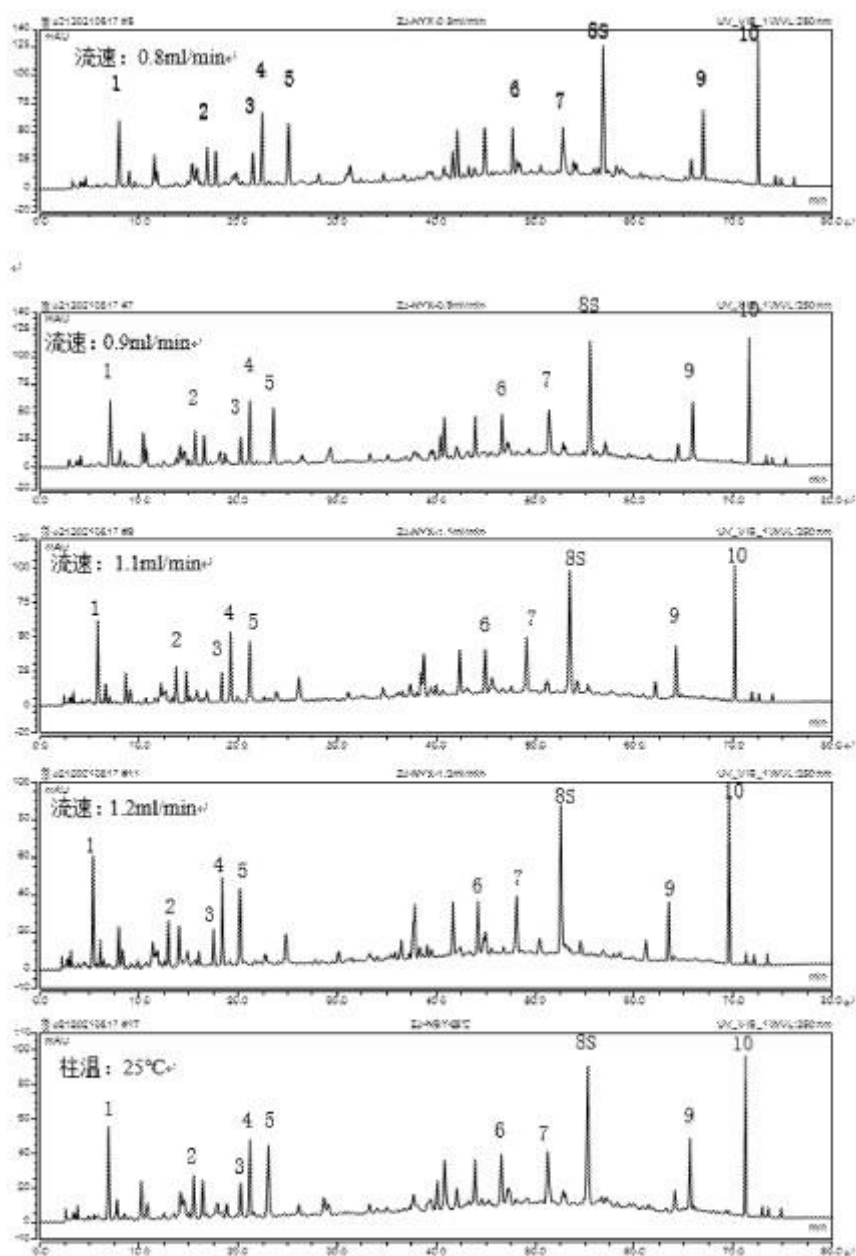


图 7





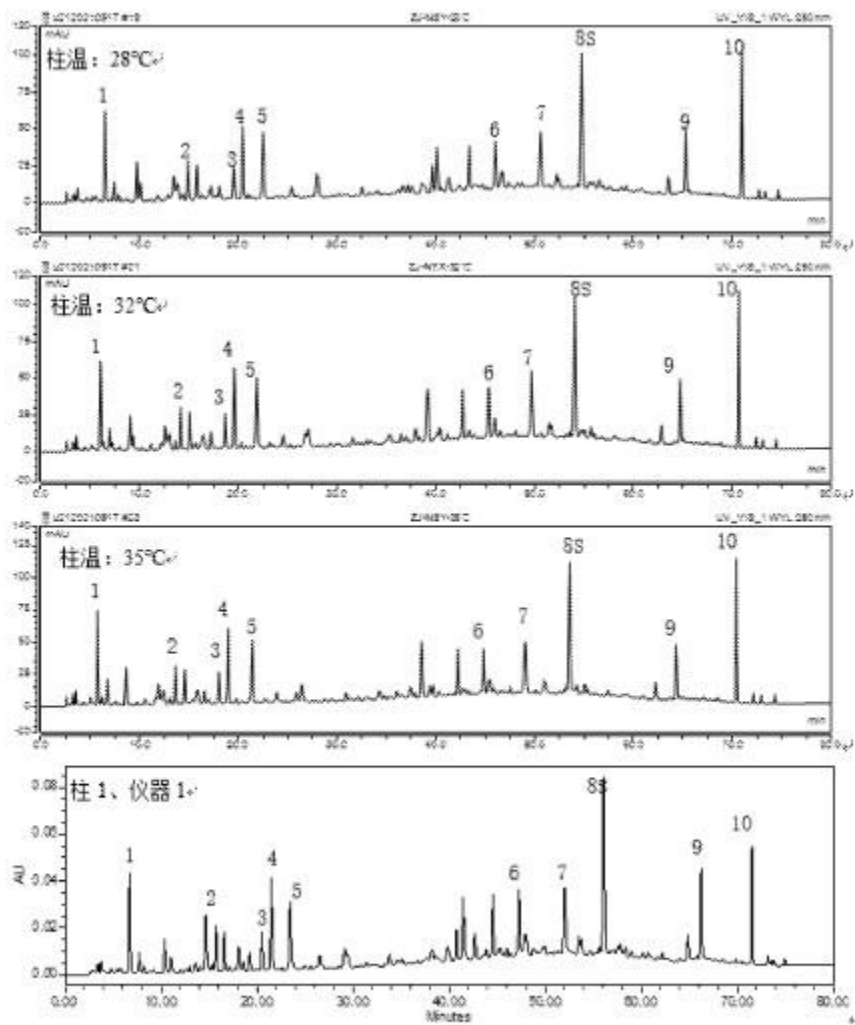


图 8

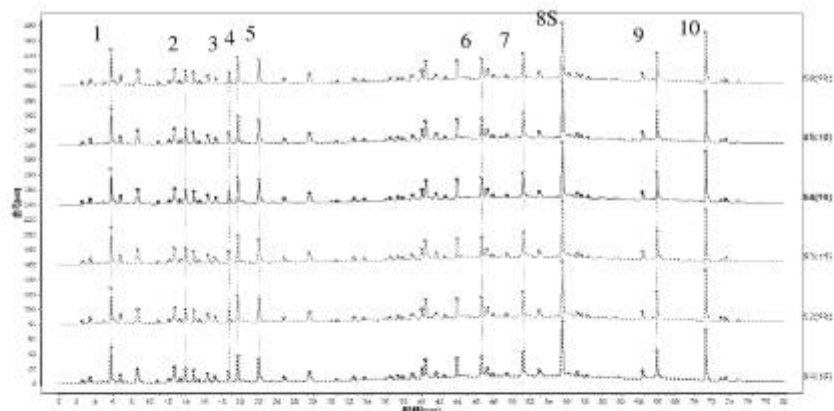


图 9

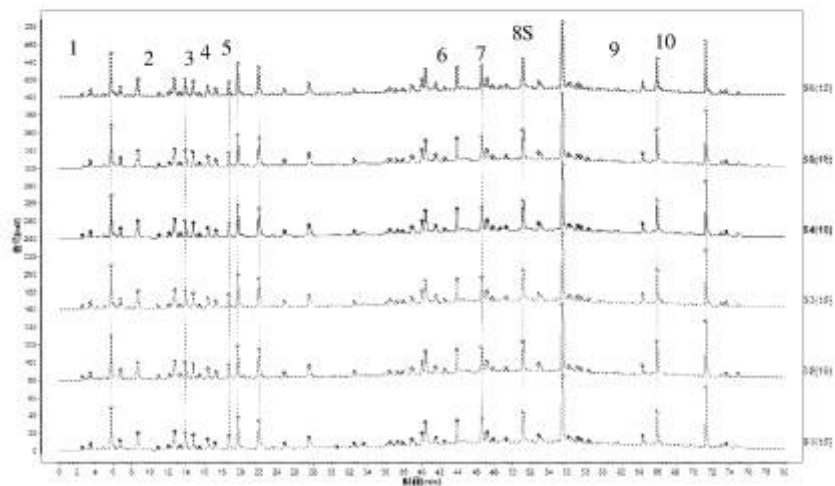


图 10

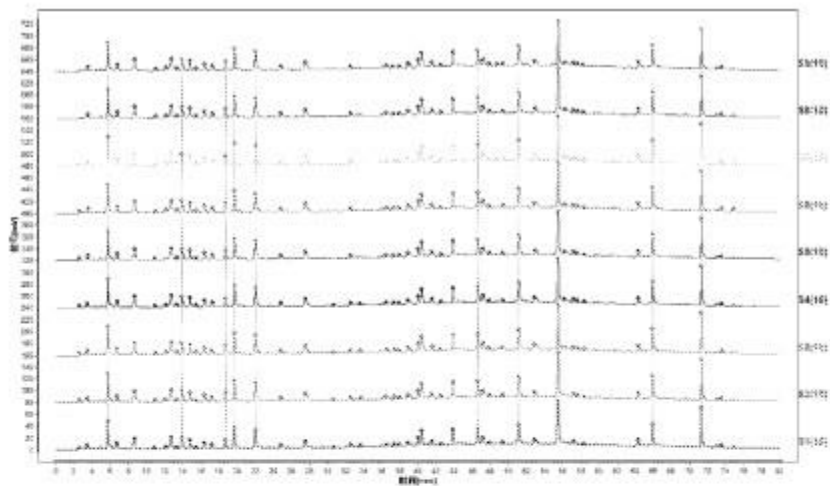


图 11

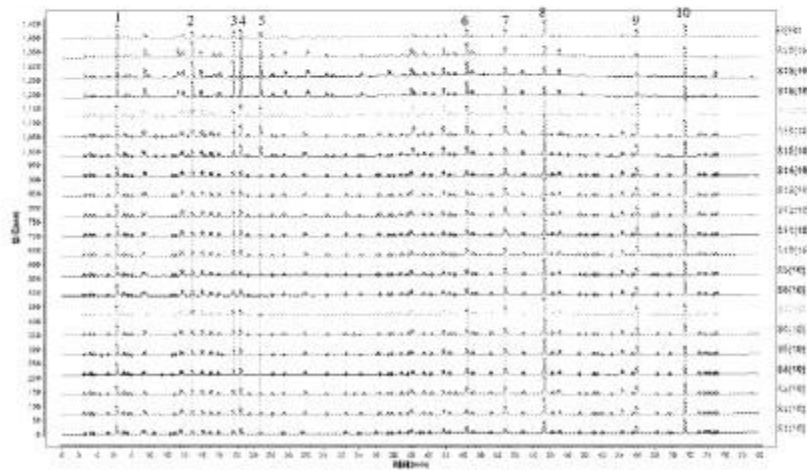


图 12

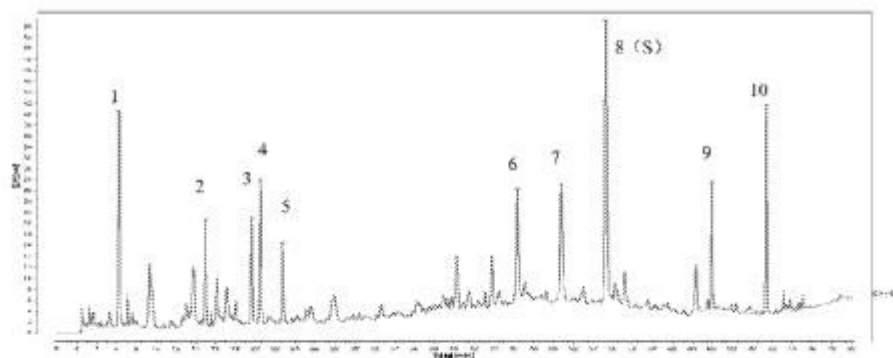
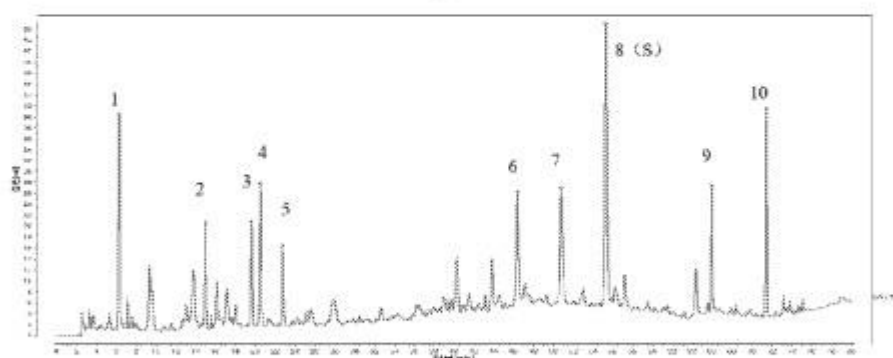


图 13



峰1: 腺嘌呤 峰2: 尿苷 峰3: 鸟苷 峰4: 肌苷 峰5: 5-羟甲基糠醛 峰6: 厚朴苷A  
峰7: 佛手酚葡萄糖苷 峰8 (S): 紫花前胡苷 峰9: 6'-O-(反式阿魏酰基)-紫花前胡苷  
峰10: 茴香酸对羟基苯乙酮

图14

**ພາກທີ I**

**(Part I)**

**ສິດທິບັດ ແລະ ອະນຸສິດທິບັດ  
(Patent and Petty Patent)**

**3. ການປ່ຽນແປງ**

**(Changes)**

**ພາກທີ I**

**(Part I)**

**ສິດທິບັດ ແລະ ອະນຸສິດທິບັດ  
(Patent and Petty Patent)**

**4. ການດັດແກ້**

**(Amendments)**

**ພາກທີ II**  
**(Part II)**  
**ແບບອຸດສາຫະກຳ**  
**(Industrial Design)**

**1. ຄຳຮ້ອງ**  
**(Applications)**

ຄຳອະທິບາຍກ່ຽວກັບລະຫັດຫຍໍ້  
**(Introduction of Codes)**

- (21) ເລກທີ ຄຳຮ້ອງ (Filing Number)
- (22) ວັນທີ ຄຳຮ້ອງ (Filing Date)
- (30) ວັນທີ ບຸລິມາສິດ (Priority Date)
- (51) ໝວດ (Locarno Classification)
- (54) ຊື່ຂອງແບບອຸດສາຫະກຳ (Title)
- (71) ຊື່ ແລະ ທີ່ຢູ່ ຂອງເຈົ້າຂອງ (Owner Name and Address)
- (72) ຊື່ຜູ້ອອກແບບ (Designer Name)
- (74) ຊື່ຕົວແທນ (Representative Name)
- (55) ຮູບພາບ (Pictures)

**ພາກທີ II**  
**(Part II)**  
**ແບບອຸດສາຫະກຳ**  
**(Industrial Design)**

**2. ຜົນການຈົດທະບຽນ**  
**(Registration)**

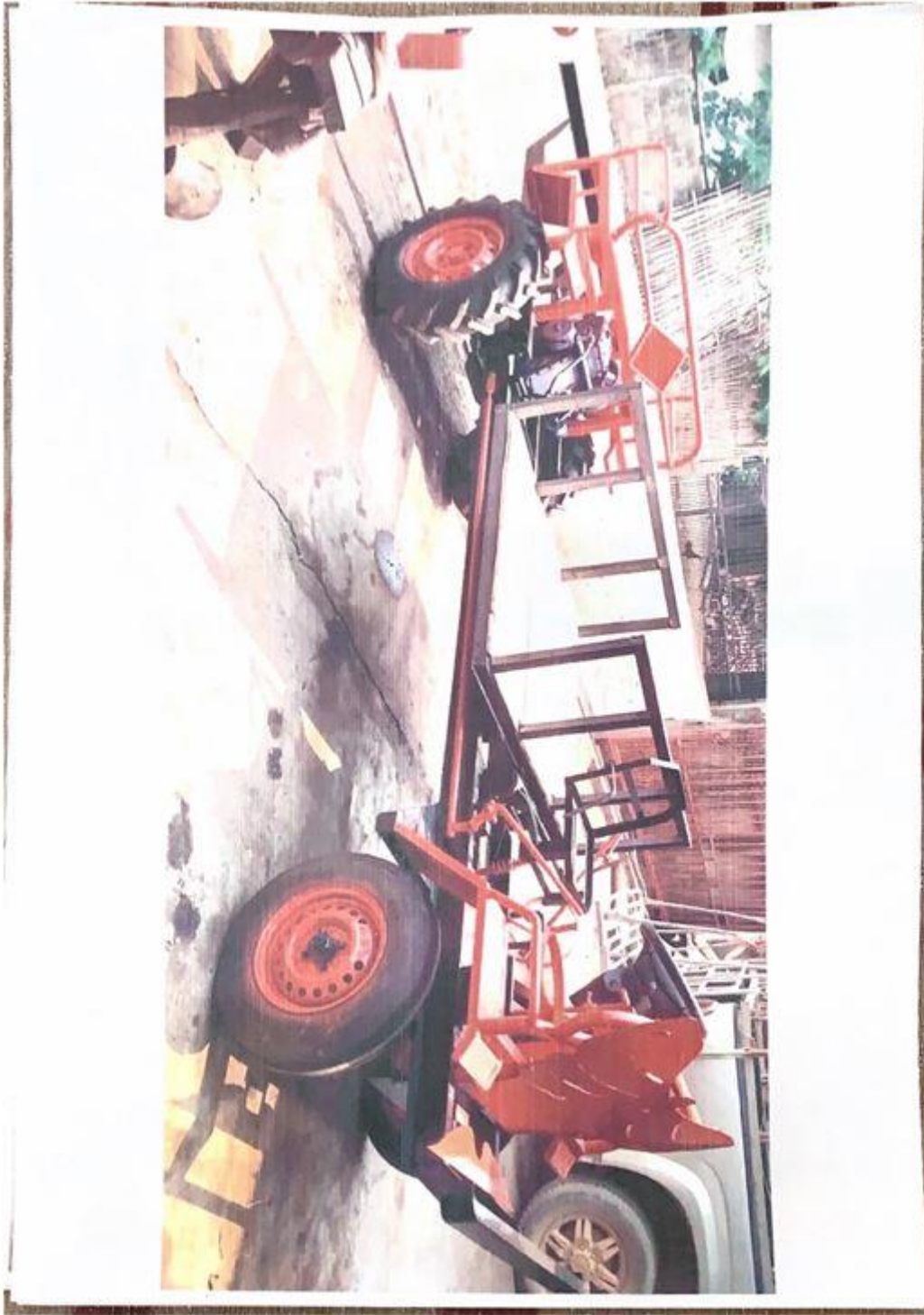
**ຄຳອະທິບາຍກ່ຽວກັບລະຫັດຫຍໍ້**  
**(Introduction of Codes)**

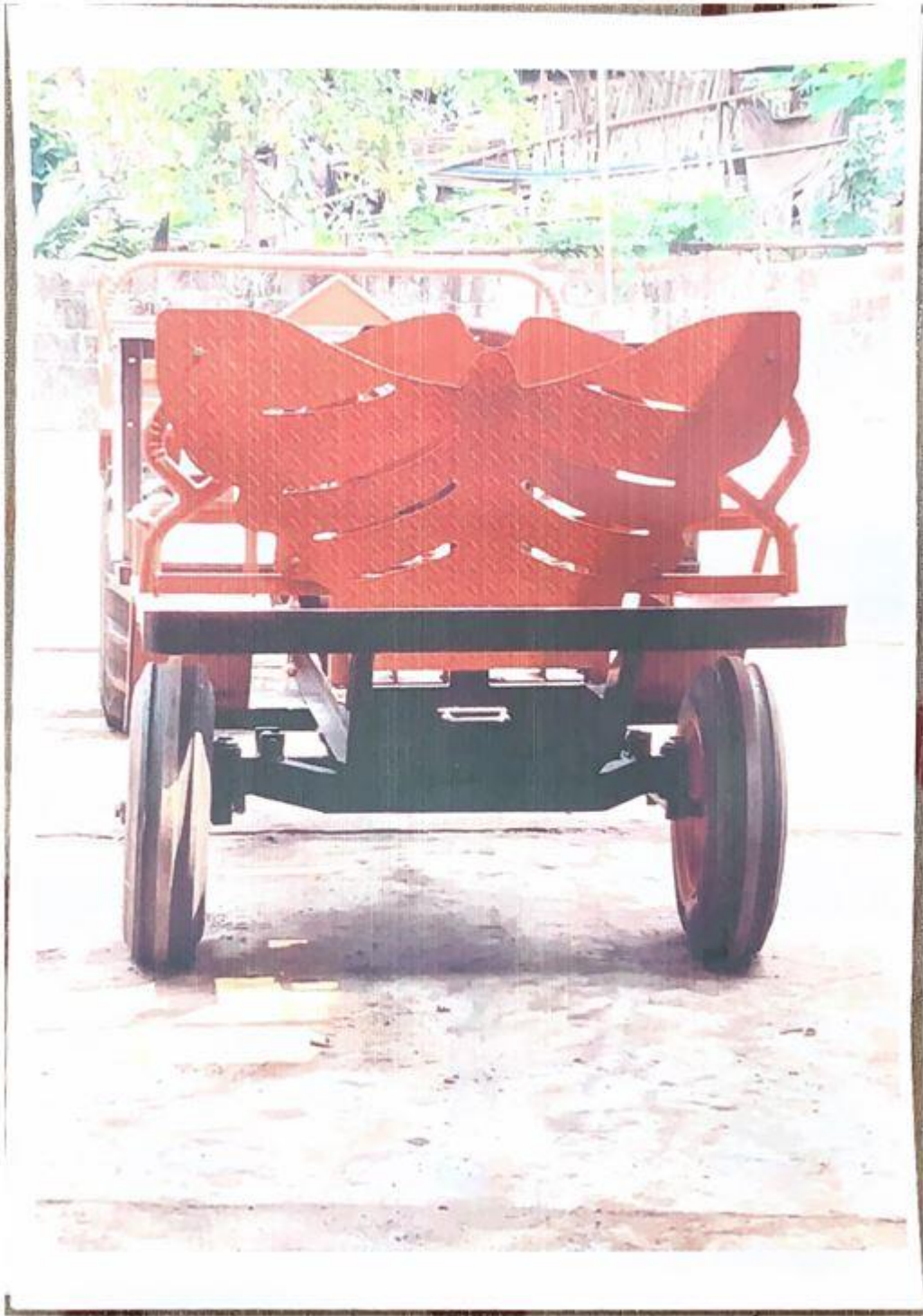
- (11) ເລກທີ ຈົດທະບຽນ (Registration Number)
- (15) ວັນທີ ຈົດທະບຽນ (Registration Date)
- (21) ເລກທີ ຍືນຄຳຮ້ອງ (Filing Number)
- (22) ວັນທີ ຍືນຄຳຮ້ອງ (Filing Date)
- (30) ວັນທີ ບຸລິມາສິດ (Priority Date)
- (17) ວັນທີ ໝົດອາຍຸ (Expiration Date)
- (51) ໝວດ (Locarno Classification)
- (54) ຊື່ຂອງແບບອຸດສາຫະກຳ (Title)
- (71) ຊື່ ແລະ ທີ່ຢູ່ ຂອງເຈົ້າຂອງ (Owner Name and Address)
- (72) ຊື່ຜູ້ອອກແບບ (Designer Name)
- (74) ຊື່ຕົວແທນ (Representative Name)
- (55) ຮູບພາບ (Pictures)

Official Gazette of Industrial Property Vol. 359, 05/06/2026

- |      |  |      |            |
|------|--|------|------------|
| (11) | No. 695  | (21) | ID 695     |
| (15) | 03/06/2026   | (22) | 24/04/2025 |
| (28) |  | (17) | 24/04/2030 |
| (30) |  | (51) | 15-03      |
| (54) | ອີແຕນຊິງເທບບົວທອງ ສ່ວນບຸກຄົນ                                 |      |            |
| (71) | ທ່ານ ນາງ ບົວທອງ ພິງນີໄຊ<br>ບ້ານ ໂພນງາມ ເມືອງໜີ້ນ ແຂວງວຽງຈັນ. |      |            |
| (72) | ທ່ານ ແກ້ວມະນີ ພິງນີໄຊ.                                       |      |            |
| (74) | .  |      |            |
| (55) |  |      |            |



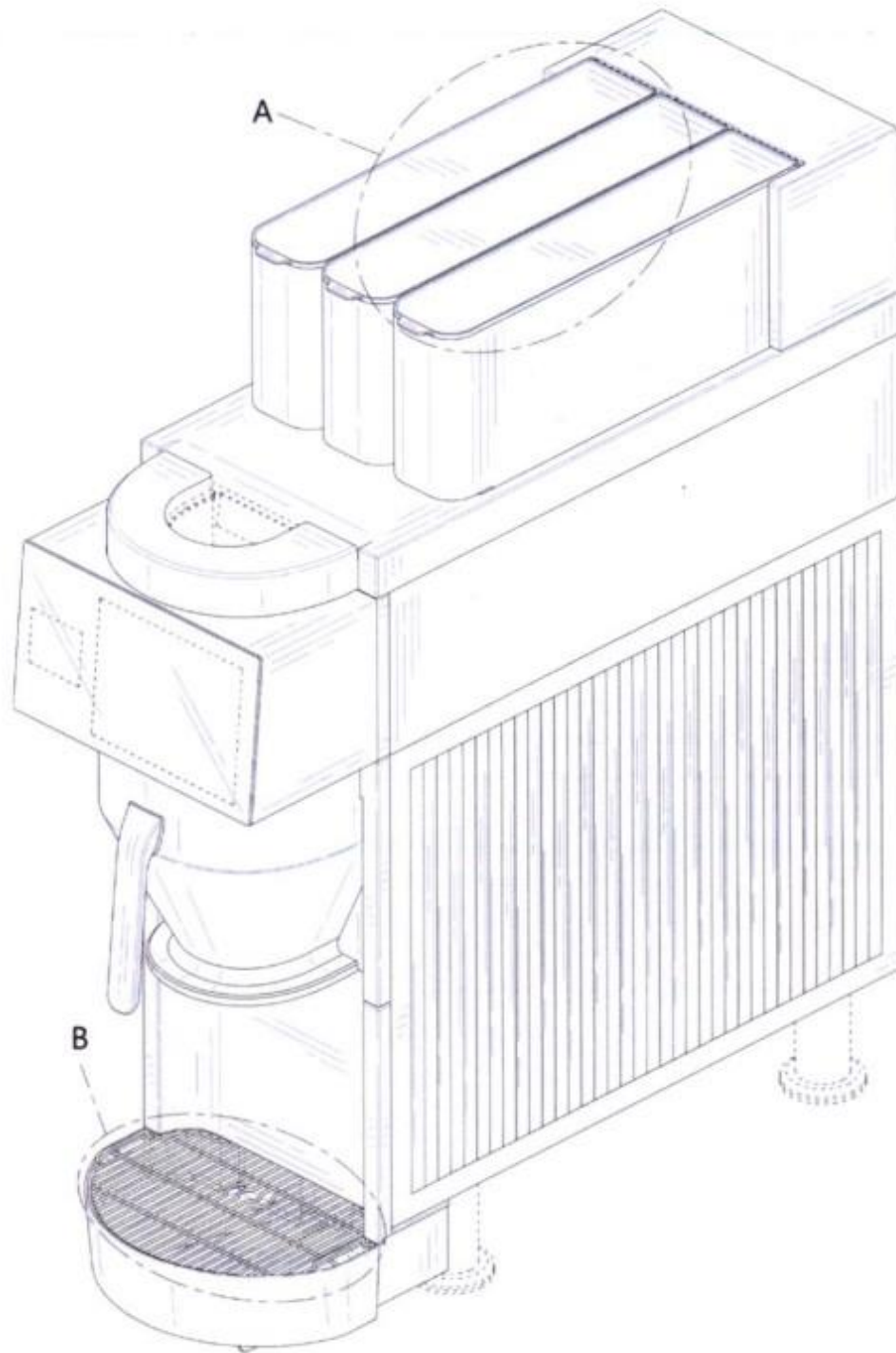


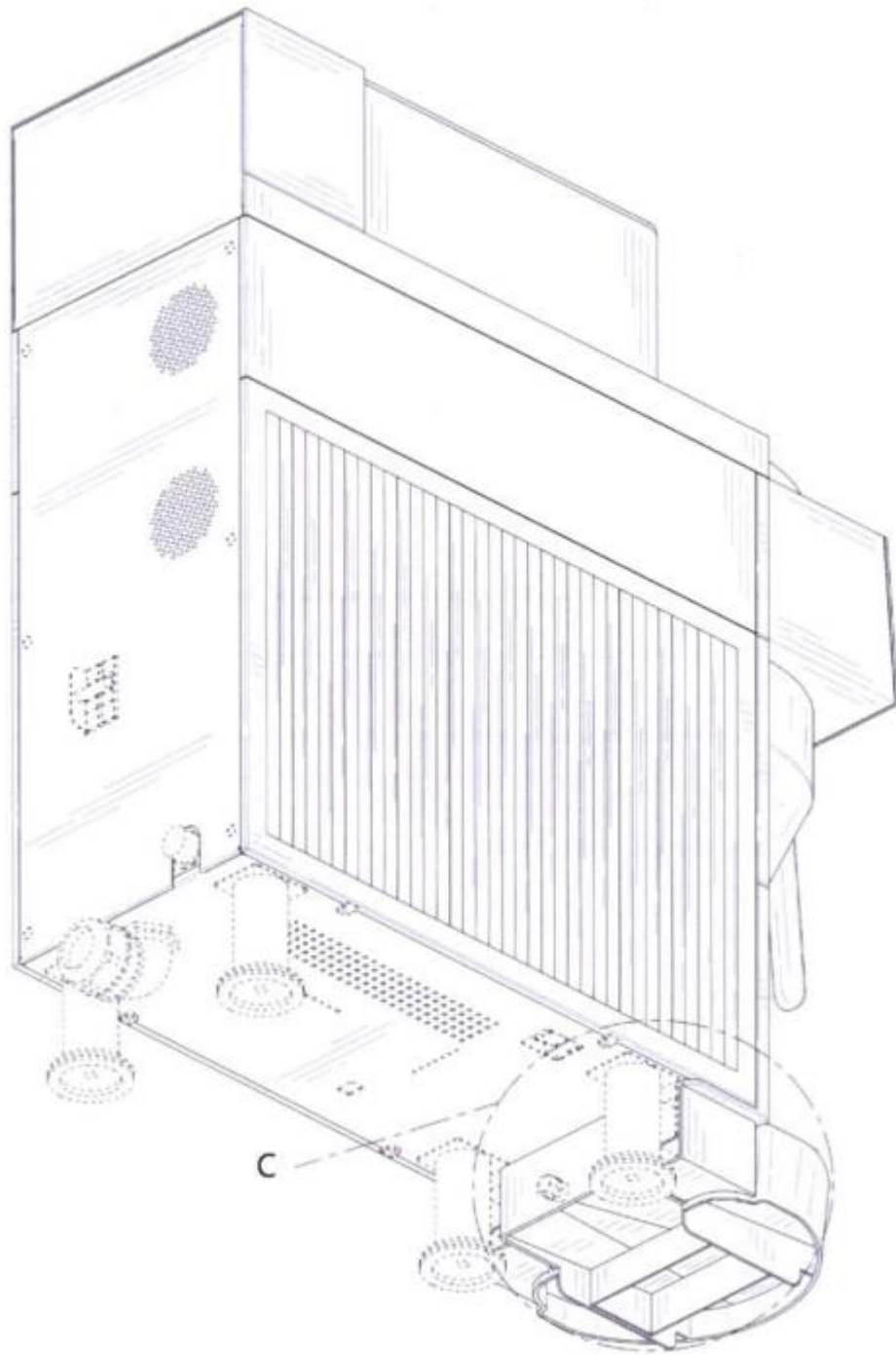


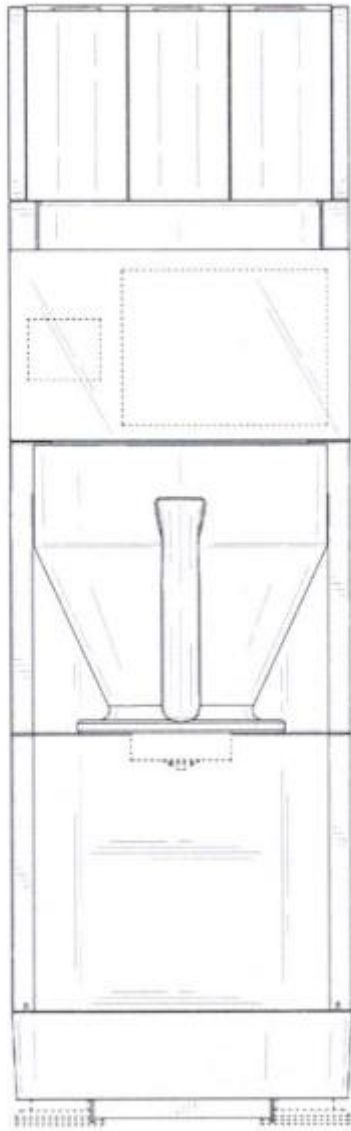


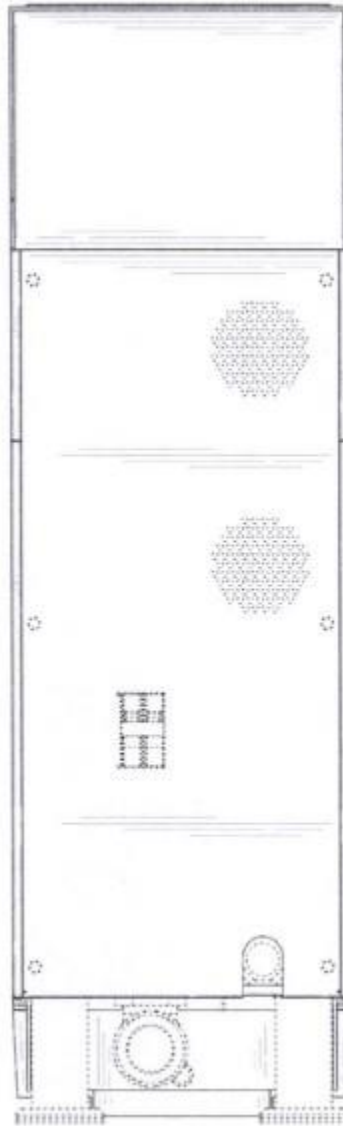
Official Gazette of Industrial Property Vol. 359, 05/06/2026

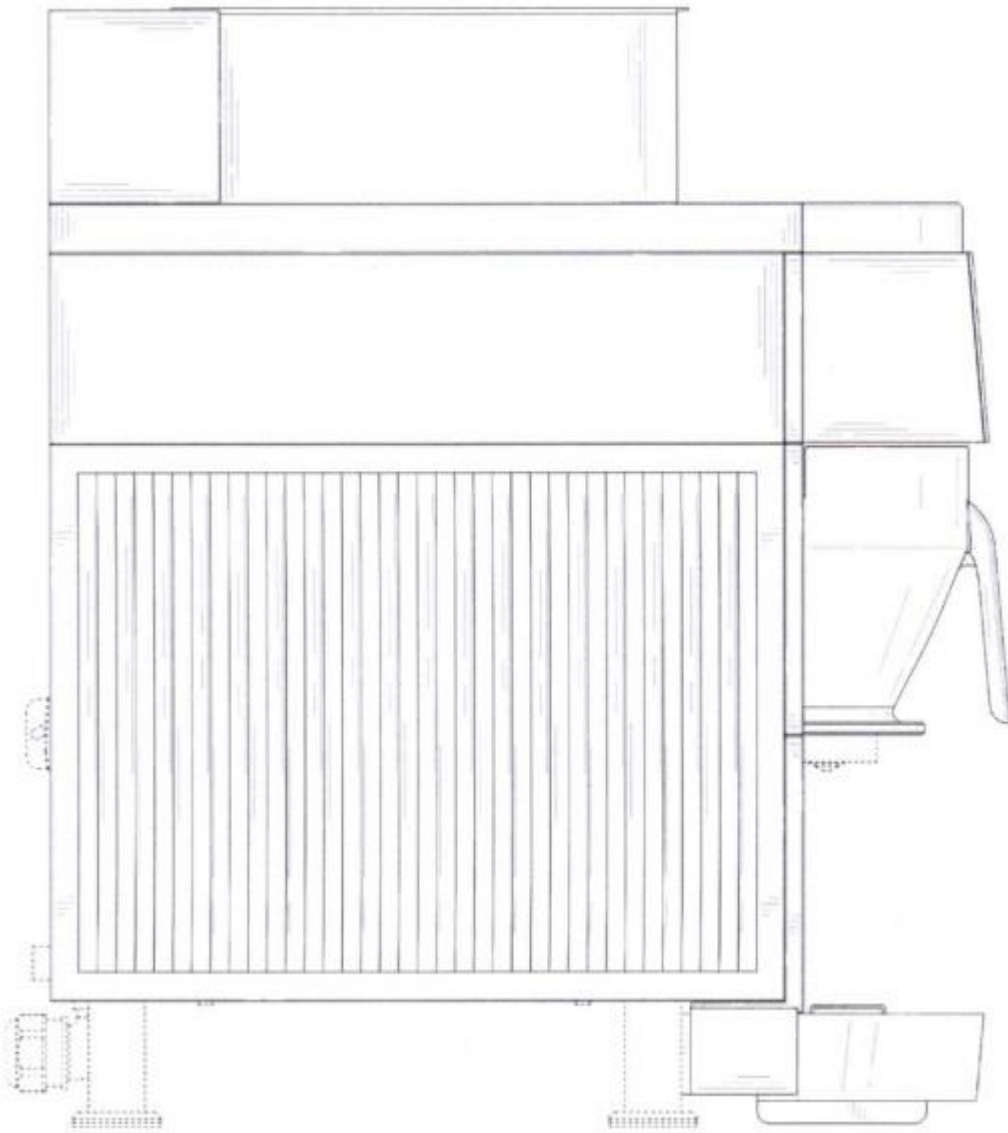
- |      |  |      |            |
|------|--|------|------------|
| (11) | No. 711  | (21) | ID 711     |
| (15) | 02/06/2026   | (22) | 01/12/2025 |
| (28) |  | (17) | 01/12/2030 |
| (30) | 2025303550746 19/06/2025 CN  | (51) | 07-02      |
| (54) | DRIP COFFEE MACHINE  |      |            |
| (71) | Luckin Food Technology (Shanghai) Co., Ltd.<br>Room 1001, 10th Floor, Building 1, No. 1728-1746 West Nanjing Road, Shanghai 200000,<br>People's Republic, China. |      |            |
| (72) | XINGJUN SHE; XIN ZHAO and SIYUN SUN.   |      |            |
| (74) | Ageless Lao Sole Co. Ltd..   |      |            |
| (55) |  |      |            |

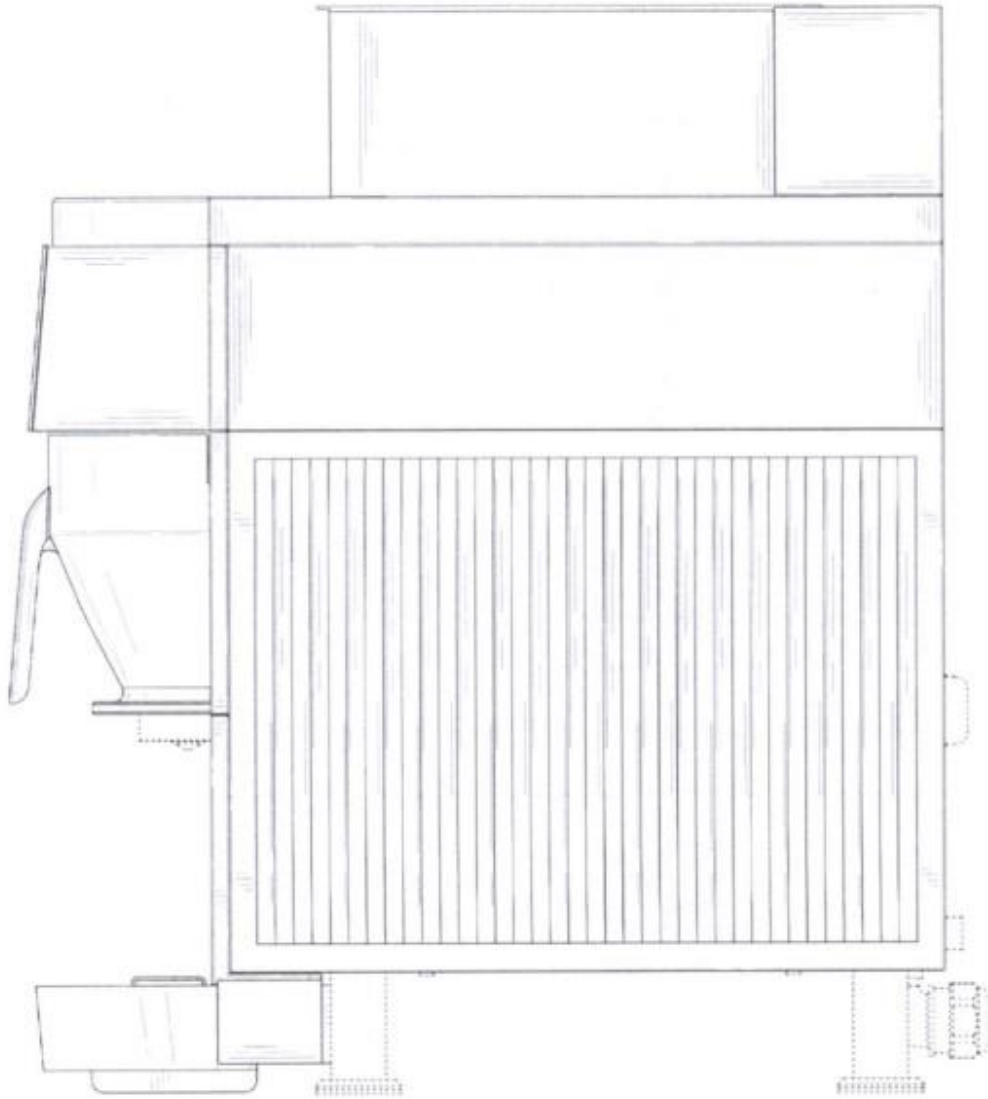


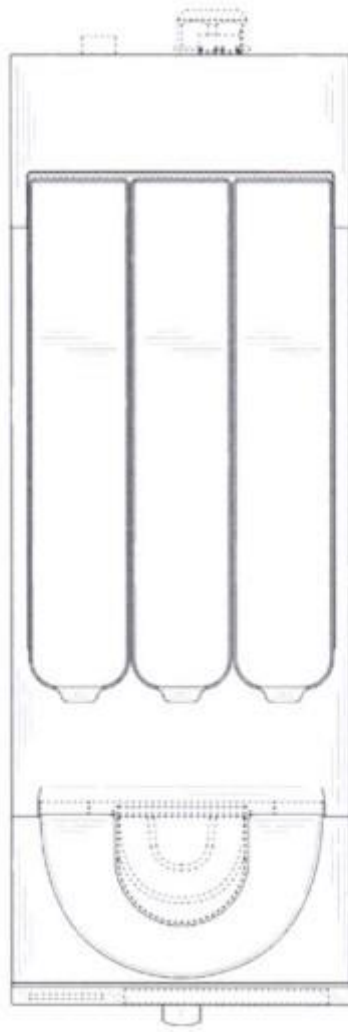


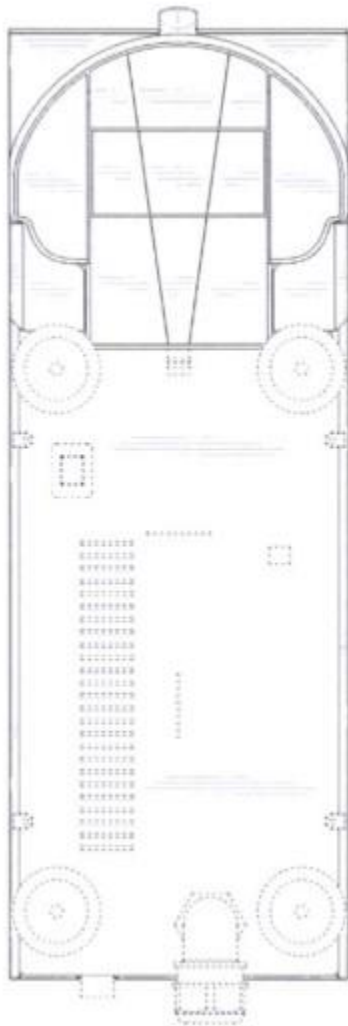


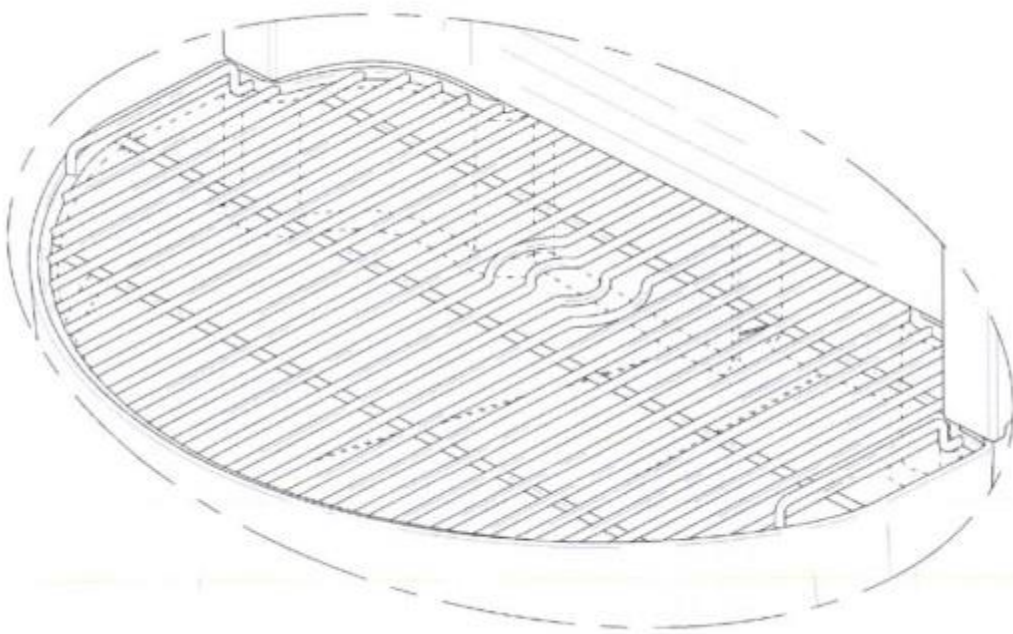
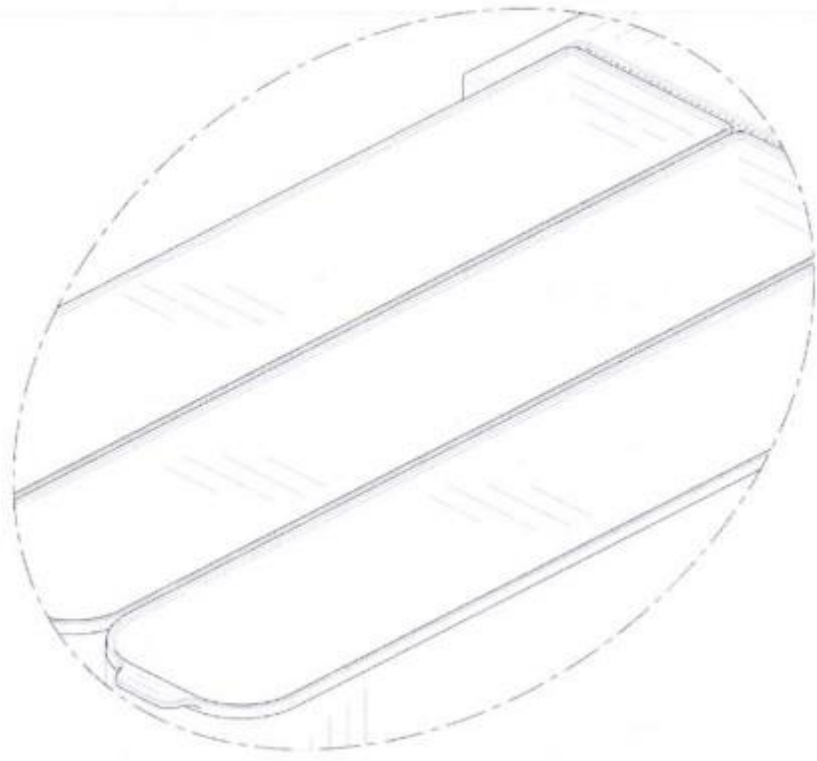


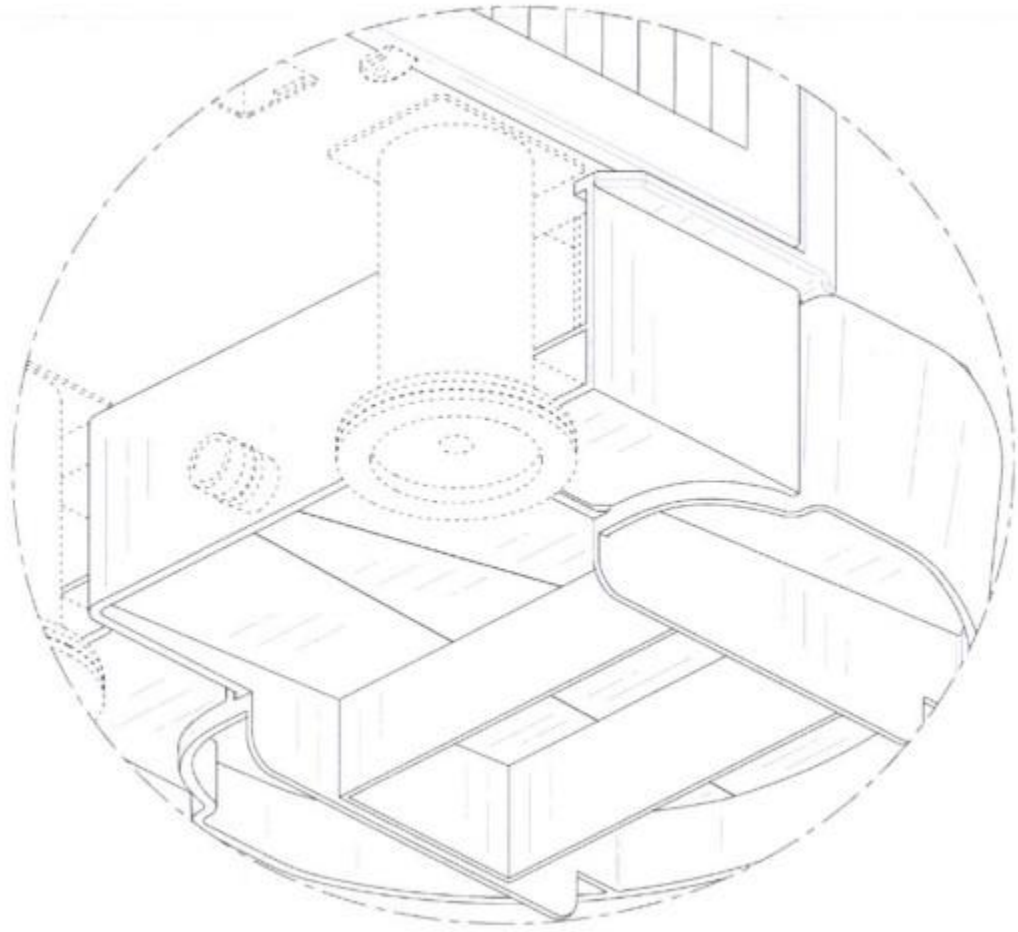












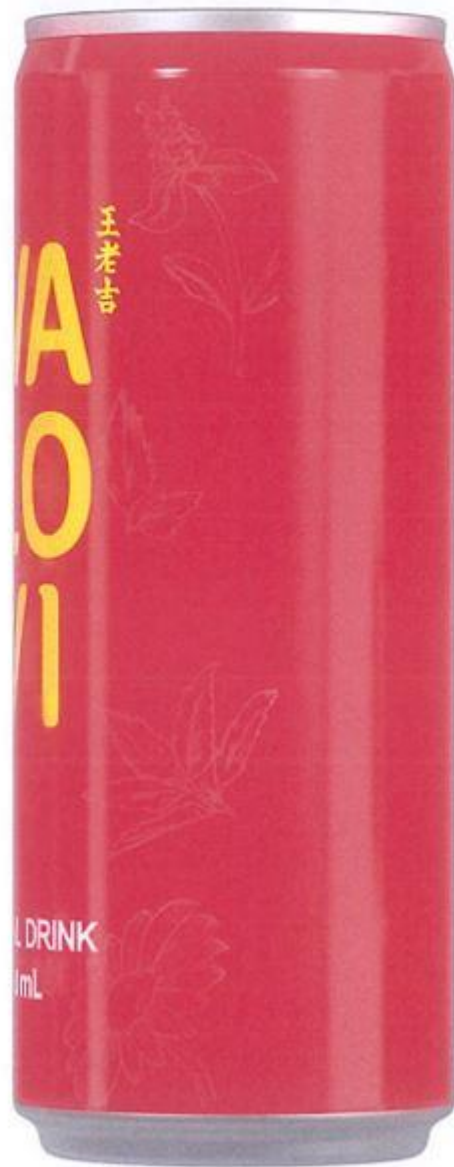
Official Gazette of Industrial Property Vol. 359, 05/06/2026

- |      |  |      |            |
|------|--|------|------------|
| (11) | No. 713  | (21) | ID 713     |
| (15) | 02/06/2026   | (22) | 08/01/2026 |
| (28) |  | (17) | 08/01/2031 |
| (30) |  | (51) | 09-03      |
| (54) | TINS FOR PACKAGING PURPOSES  |      |            |
| (71) | GUAIGZHOU WAIIGLAOJI GREAT HEALTH INDUSTRY CO., LTD.<br>Unit 1305, No.162 Gangqian Avenue South, Nansha Street, Nansha District,<br>Guangzhou, Guangdong 511458, P.R. Chin, China. |      |            |
| (72) | Kunnan CHEN; Dafeng FANG; Jizeng YE; Liangshui HUANG; Bing YAN and Hailing HOU.  |      |            |
| (74) | Tilleke & Gibbins Lao Co., Ltd.  |      |            |
| (55) |  |      |            |











**ພາກທີ II**

**(Part II)**

**ແບບອຸດສາຫະກຳ**

**(Industrial Design)**

**3. ການປ່ຽນແປງ**

**(Changes)**

**ພາກທີ II**  
**(Part II)**

**ແບບອຸດສາຫະກຳ**  
**(Industrial Design)**

**4. ການດັດແກ້**  
**(Amendments)**

**ພາກທີ III**  
**(Part III)**  
**ເຄື່ອງໝາຍການຄ້າ**  
**Trademarks**

**1. ຄໍາຮ້ອງ**  
**(Applications)**

**ຄໍາອະທິບາຍກ່ຽວກັບລະຫັດຫຍໍ້**  
**(Introduction of Codes)**

- (540) ເຄື່ອງໝາຍການຄ້າ (Trademark)
- (511) ໝວດ (Nice Classification)
- (210) ເລກທີ ຄໍາຮ້ອງ (Number of the application)
- (220) ວັນທີ ຄໍາຮ້ອງ (Date of filing of the application)
- (732) ຊື່ ແລະ ທີ່ຢູ່ ຂອງຜູ້ຍື່ນຄໍາຮ້ອງ (Name and Address of applicant)

(540) Trademark Application



(511) 09 and 36

(210) No. 54195

(220) 01/04/2026

(732) ບໍລິສັດ ພາເຈ ຈຳກັດ

ບ້ານ ໂນນຄໍ້ໃຕ້, ເມືອງ ໄຊເສດຖາ,  
ນະຄອນຫຼວງວຽງຈັນ, ສປປ ລາວ

(540) Trademark Application



(511) 25

(210) No. 54196

(220) 01/04/2026

(732) ບໍລິສັດ ໂອເຄ ການຄ້າ ຂາເຂົ້າ-ຂາອອກ ຈຳກັດຜູ້ດຽວ

ບ້ານ ຫັດສະດີ, ເມືອງ ຈັນທະບູລີ,  
ນະຄອນຫຼວງວຽງຈັນ, ສປປ ລາວ

(540) Trademark Application



(511) 21

(210) No. 54197

(220) 01/04/2026

(732) ສະມາຄົມພັດທະນາໄມ້ປ່ອງ ແລະ ເຄື່ອງປ່າຂອງດົງ  
ບ້ານ ທາດເມືອງ, ເມືອງ ຊຳເໜືອ, ແຂວງ ຫົວພັນ,  
ສປປ ລາວ

(540) Trademark Application

**WIKICAREER**

(511) 35

(210) No. 54198

(220) 01/04/2026

(732) Wikicareer Sdn Bhd  
No. 8-2 & 8-3, Setia Avenue, Jalan Setia  
Prima S U13/S, Setia Alam, Seksyen U13,  
40170 Shah Alam, Selangor, Malaysia.

(540) Trademark Application



(511) 30

(210) No. 54199

(220) 02/04/2026

(732) ຈິດຈະເລີນ ຜະລິດນ້ຳກ້ອນອານາໄມ ແລະ  
ນ້ຳດື່ມບໍລິສຸດ ສ່ວນບຸກຄົນ.  
ບ້ານ ຫາຍໂສກ, ເມືອງ ສີສັດຕະນາກ,  
ນະຄອນຫຼວງວຽງຈັນ, ສປປ ລາວ

(540) Trademark Application



(511) 09

(210) No. 54201

(220) 03/04/2026

(732) ບໍລິສັດ ແອັກມ໌ ອີ-ຄອມເມິດ ອິນເວດເມັ້ນ  
ຈຳກັດຜູ້ດຽວ  
ບ້ານ ໂພນທັນ, ເມືອງ ໄຊເສດຖາ,  
ນະຄອນຫຼວງວຽງຈັນ, ສປປ ລາວ

(540) Trademark Application

**I3DE MARZO**

(511) 25 and 35

(210) No. 54202

(220) 03/04/2026

(732) Hangzhou Yishisandiyi Brand Management  
Co., Ltd.

Room 131-135, Building 2, No. 253 Tinglan  
Street, Qiaosi Street, Linping District,  
Hangzhou City, Zhejiang Province, China.

(540) Trademark Application



(511) 29

(210) No. 54203

(220) 03/04/2026

(732) Shandong Qihui Enterprise Development  
Group Co., Ltd.

Industrial Park, Liguan Town, Lanshan  
District, Linyi City, Shandong Province,  
China.

(540) Trademark Application

**AFMAT**

(511) 16

(210) No. 54204

(220) 03/04/2026

(732) Shenzhen Zemiao Network Technology Co.,  
Ltd.

Rm102, 1st F, Bldg 1, No. 2 Reservoir Rd,  
Nankeng Comm, Bantian St, Longgang Dist,  
Shenzhen, China.

(540) Trademark Application



(511) 29 and 30

(210) No. 54205

(220) 06/04/2026

(732) ບໍລິສັດ ຫົວເຝິງ ນໍາເຂົ້າ ແລະ ສົ່ງອອກ ຈໍາກັດ  
ຖະໜົນ 13 ເໜືອ, ບ້ານ ນາເລົ່າ,  
ເມືອງ ສີໂຄດຕະບອງ, ນະຄອນຫຼວງວຽງຈັນ,  
ສປປ ລາວ

(540) Trademark Application

INDOCHINA  DUTYFREE

(511) 35

(210) No. 54206

(220) 06/04/2026

(732) ບໍລິສັດ ແກຣນວິວ ພອບເຜີຕີ້ ຈຳກັດຜູ້ດຽວ  
ຖະໜົນ ໄກສອນພິມວິຫານ, ບ້ານ ສີບຸນເຮືອງ,  
ເມືອງ ຈັນທະບູລີ, ນະຄອນຫຼວງວຽງຈັນ, ສປປ ລາວ

(540) Trademark Application



(511) 05

(210) No. 54207

(220) 06/04/2026

(732) UNI-CHARM CORPORATION  
182 Shimobun, Kinsei-cho, Shikokuchuo-shi,  
Ehime-ken, Japan.

(540) Trademark Application



(511) 03

(210) No. 54208

(220) 06/04/2026

(732) UNI-CHARM CORPORATION

182 Shimobun, Kinsei-cho, Shikokuchuo-shi,  
Ehime-ken, Japan.

(540) Trademark Application



(511) 03

(210) No. 54209

(220) 06/04/2026

(732) UNI-CHARM CORPORATION

182 Shimobun, Kinsei-cho, Shikokuchuo-shi,  
Ehime-ken, Japan.

(540) Trademark Application



(511) 43

(210) No. 54210

(220) 07/04/2026

(732) ວິສາຫະກິດສ່ວນບຸກຄົນ ໝີ່ໂມ່ງ ຄາເຟ  
ບ້ານ ສຸນັນທາ, ນະຄອນໄກສອນ ພິມວິຫານ,  
ແຂວງ ສະຫວັນນະເຂດ, ສປປ ລາວ

(540) Trademark Application



LUX  
HOTEL  
LUANG PRABANG

(511) 43

(210) No. 54211

(220) 07/04/2026

(732) ນາງ ຄຳຜັນ ປັນຍາສິລິ  
ບ້ານ ນາຊາງ, ນະຄອນ ຫຼວງພະບາງ,  
ແຂວງ ຫຼວງພະບາງ, ສປປ ລາວ

(540) Trademark Application



(511) 02

(210) No. 54212

(220) 07/04/2026

(732) ບໍລິສັດ ບີຊີຊີ ອຸດສາຫະກຳ ຈຳກັດຜູ້ດຽວ

ບ້ານນາພອກ, ເມືອງໄຊທານີ, ນະຄອນຫຼວງວຽງຈັນ,  
ສປປ ລາວ

(540) Trademark Application



(511) 03

(210) No. 54213

(220) 07/04/2026

(732) NARAK-TIARA CO.,LTD.

1/9 Moo 2, Rama 2 Road, Tha Sai, Mueang  
Samut Sakhon, Samut Sakhon 74000,  
Thailand.

(540) Trademark Application

**PALMOLIVE**

(511) 03

(210) No. 54214

(220) 07/04/2026

(732) Colgate-Palmolive Company

300 Park Avenue, New York 10022,  
United States of America.

(540) Trademark Application



(511) 35

(210) No. 54216

(220) 07/04/2026

(732) ວິສາຫະກິດສ່ວນບຸກຄົນ ອໍລ໌ ມາດ

ບ້ານ ອີໄລເໜືອ, ເມືອງ ນາຊາຍທອງ,  
ນະຄອນຫຼວງວຽງຈັນ, ສປປ ລາວ

(540) Trademark Application



(511) 30

(210) No. 54217

(220) 07/04/2026

(732) ວິສາຫະກິດສ່ວນບຸກຄົນ ຮ້ານ ຈຳໜ່າຍ

ເຄັກຈິນດາມະນີ ແລະ ເບີເກີລີ້

ບ້ານ ຊຸນຕາທິງ, ເມືອງ ສີໂຄດຕະບອງ,

ນະຄອນຫຼວງວຽງຈັນ, ສປປ ລາວ

(540) Trademark Application



(511) 19

(210) No. 54218

(220) 08/04/2026

(732) ບໍລິສັດ ອື່ຫຼຽນການຄ້າ ຂາເຂົ້າ-ຂາອອກ ຈຳກັດຜູ້ດຽວ.

ບ້ານ ໜອງບຶກໃຕ້, ເມືອງ ສີໂຄດຕະບອງ,

ນະຄອນຫຼວງວຽງຈັນ, ສປປ ລາວ

(540) Trademark Application



(511) 41 and 43

(210) No. 54219

(220) 08/04/2026

(732) ບໍລິສັດ ເບັນຊຸ ບໍລິການ (ລາວ) ຈຳກັດຜູ້ດຽວ.  
ໜ່ວຍ 04, ບ້ານ ຂົວຫຼວງ, ເມືອງ ຈັນທະບູລີ,  
ນະຄອນຫຼວງວຽງຈັນ, ສປປ ລາວ

(540) Trademark Application



(511) 35

(210) No. 54220

(220) 08/04/2026

(732) Ashley Furniture Industries, LLC  
1670 East, 8th Avenue, Tampa,  
Florida 33605, United States of America.

(540) Trademark Application



(511) 29, 30, 32, 35 and 43

(210) No. 54221

(220) 08/04/2026

(732) Jinan Baodao Enterprise Management

Consulting Co., Ltd.

Room 2202, Block A, Xicheng Xijin Times

Center, Huaiyin District, Jinan City,

Shandong, China.

(540) Trademark Application



(511) 43

(210) No. 54222

(220) 08/04/2026

(732) YUEN KEE FOOD GROUP CO., LTD.

Room 2001-2021, 20/F, Baoneng Financial

Building, Lecong Town, Shunde District,

Foshan City, Guangdong Province, China.

(540) Trademark Application

**GOLD+**

(511) 35 and 39

(210) No. 54223

(220) 08/04/2026

(732) HERTZ SYSTEM, INC.

8501 Williams Road, Estero, FL 33928,  
United States of America.

(540) Trademark Application

**冒大仙麻辣烫**  
Master Spicy Hot Pot

(511) 43

(210) No. 54224

(220) 08/04/2026

(732) Chengdu Maodaxian Catering Management  
Co., Ltd.

Units 1, 6, 7, 8, 9 and 10, 47/F, Office  
Building 2, International Financial Center,  
No. 1, Section 3, Hongxing Road, Jinjiang  
District, Chengdu, Sichuan, China.

(540) Trademark Application



(511) 32

(210) No. 54225

(220) 09/04/2026

(732) ໂຮງງານ ວາດສະໜາ ເຫຼົ້າ ແລະ ເຄື່ອງດື່ມ

ບ້ານ ຍາຜະ, ເມືອງ ສີໂຄດຕະບອງ,

ນະຄອນຫຼວງວຽງຈັນ, ສປປ ລາວ

(540) Trademark Application



(511) 36

(210) No. 54226

(220) 09/04/2026

(732) ບໍລິສັດ ສະຖາບັນການເງິນຈຸລະພາກທີ່ບໍ່ຮັບເງິນຝາກ

ຈັນຈະເລີນ ຈຳກັດຜູ້ດຽວ

ບ້ານ ທົ່ງຂັນຄຳ, ເມືອງ ຈັນທະບູລີ,

ນະຄອນຫຼວງວຽງຈັນ, ສປປ ລາວ

(540) Trademark Application

**WONDER NATION**

(511) 25

(210) No. 54227

(220) 09/04/2026

(732) Walmart Apollo, LLC

1 Customer Drive, Mail Stop 0215,  
Bentonville, Arkansas 72716,  
United States of America.

(540) Trademark Application

**GICN**

(511) 05 and 30

(210) No. 54229

(220) 09/04/2026

(732) ບໍລິສັດ ລາວ ເອັນຟີຊີ ເທັກໂນໂລຊີຊີວະພາບ ຈຳກັດ  
ບ້ານ ນາຊາງ, ນະຄອນຫຼວງພະບາງ,  
ແຂວງ ຫຼວງພະບາງ, ສປປ ລາວ.

(540) Trademark Application



(511) 03, 16 and 21

(210) No. 54230

(220) 10/04/2026

(732) ບໍລິສັດ ຈິງຖິງ ອຸດສາຫະກຳ ລາວ-ຫຼຍຮິງ ເຕັກໂນໂລຢີ  
ແລະ ພັດທະນາ ຈຳກັດ  
ບ້ານ ພະຂາວ, ເມືອງ ໄຊທານີ, ນະຄອນຫຼວງວຽງຈັນ,  
ສປປ ລາວ

(540) Trademark Application



(511) 03, 16 and 21

(210) No. 54231

(220) 10/04/2026

(732) ບໍລິສັດ ຈິງຖິງ ອຸດສາຫະກຳ ລາວ-ຫຼຍຮິງ ເຕັກໂນໂລຢີ  
ແລະ ພັດທະນາ ຈຳກັດ  
ບ້ານ ພະຂາວ, ເມືອງ ໄຊທານີ, ນະຄອນຫຼວງວຽງຈັນ,  
ສປປ ລາວ

(540) Trademark Application



(511) 29

(210) No. 54232

(220) 10/04/2026

(732) XIA, XIAODONG

ບ້ານ ໜອງໜ້ຽວ, ເມືອງ ສີໂຄດຕະບອງ,  
ນະຄອນຫຼວງວຽງຈັນ, ສປປ ລາວ

(540) Trademark Application



(511) 07 and 21

(210) No. 54234

(220) 10/04/2026

(732) ບໍລິສັດ ຊີຢາງ ການຄ້າ ຂາເຂົ້າ-ຂາອອກ ຈຳກັດ

ບ້ານ ສີສະຫວາດ, ເມືອງ ບໍລິຄັນ, ແຂວງ ບໍລິຄຳໄຊ,  
ສປປ ລາວ

(540) Trademark Application



(511) 32

(210) No. 54235

(220) 10/04/2026

(732) ວິສາຫະກິດ ສ່ວນບຸກຄົນ ຄຳກອງ ຂາຍເຄື່ອງຢ່ອຍ, ຜະລິດ ແລະ ຈຳໜ່າຍນໍ້າດື່ມບໍລິສຸດ ບ້ານ ຫາດອນແກ້ວ, ເມືອງ ປາກທາ, ແຂວງ ບໍ່ແກ້ວ, ສປປ ລາວ.

(540) Trademark Application

**BEARISTA**

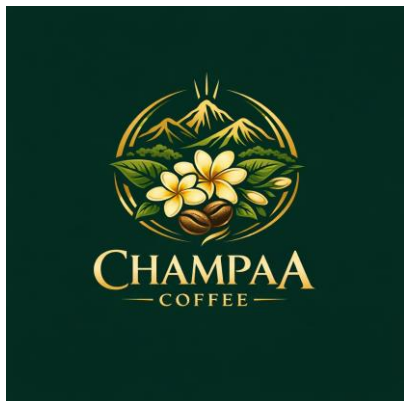
(511) 14 and 21

(210) No. 54236

(220) 10/04/2026

(732) Starbucks Corporation  
2401 Utah Avenue South, Seattle,  
Washington, 98134, United States of America.

(540) Trademark Application



(511) 30 and 43

(210) No. 54237

(220) 10/04/2026

(732) SOMPATTHANA VONGKHAMCHANH

Patthana Village, km7, Pakse District,  
Champasak Province, LAO PDR.

(540) Trademark Application



(511) 07 and 08

(210) No. 54238

(220) 10/04/2026

(732) MASADA SEISAKUSHO (HUZHOU)

CO.,LTD.

NO.927 ZHONGXING NORTH ROAD,  
DEQING COUNTY, HUZHOU CITY,  
ZHEJIANG PROVINCE, CHINA.

(540) Trademark Application

ESVERON  
愛斯威倫

(511) 25

(210) No. 54239

(220) 13/04/2026

(732) Huang Xinfu

No. 5, West of Shangpinfang Road, Longxi  
2nd Village, Dongyong Town, Cheng  
District, Shanwei City, Guangdong Province,  
China.

(540) Trademark Application

***QubeApps***

(511) 42

(210) No. 54241

(220) 13/04/2026

(732) Qube Apps Solutions Sdn. Bhd.

No. 2-32A1, Jalan Desa 1/1, Desa Aman  
Puri, 52100 Kepong, Kuala Lumpur,  
Malaysia.

(540) Trademark Application



(511) 35

(210) No. 54242

(220) 13/04/2026

(732) Qube Apps Solutions Sdn. Bhd.

No. 2-32A1, Jalan Desa 1/1, Desa Aman  
Puri, 52100 Kepong, Kuala Lumpur,  
Malaysia.

(540) Trademark Application



(511) 42

(210) No. 54243

(220) 13/04/2026

(732) Qube Apps Solutions Sdn. Bhd.

No. 2-32A1, Jalan Desa 1/1, Desa Aman  
Puri, 52100 Kepong, Kuala Lumpur,  
Malaysia.

(540) Trademark Application

ALOFT BY MARRIOTT

(511) 35 and 43

(210) No. 54244

(220) 13/04/2026

(732) Marriott Worldwide Corporation

7750 Wisconsin Avenue, Bethesda,

Maryland 20814, United States of America.

(540) Trademark Application

  
BY MARRIOTT

(511) 35 and 43

(210) No. 54245

(220) 13/04/2026

(732) Marriott Worldwide Corporation

7750 Wisconsin Avenue, Bethesda,

Maryland 20814, United States of America.

(540) Trademark Application

**Hypershell**

(511) 07, 10 and 28

(210) No. 54246

(220) 15/04/2026

(732) Hypershell Co., Ltd.

Room 118, Building 20, No. 1-42, Lane 83,  
Hongxiang North Road, Shanghai City, China.

(540) Trademark Application



(511) 07, 10 and 28

(210) No. 54247

(220) 15/04/2026

(732) Hypershell Co., Ltd.

Room 118, Building 20, No. 1-42, Lane 83,  
Hongxiang North Road, Shanghai City,  
China.

(540) Trademark Application



阿袁  
YUEN

(511) 43

(210) No. 54248

(220) 17/04/2026

(732) Yuen Kee Food Group Co., Ltd.

Room 2001-2021, 20/F, Baoneng Financial  
Building, Lecong Town, Shunde District,  
Foshan City, Guangdong Province, China.

(540) Trademark Application



(511) 12

(210) No. 54249

(220) 17/04/2026

(732) Shineray Automobile Co., Ltd.

111 Xinyuan Avenue, Xincheng District,  
Fuling, Chongqing, China.

(540) Trademark Application



(511) 12

(210) No. 54250

(220) 17/04/2026

(732) Shenzhen COLS Motorcycle Trade Co., Ltd.  
No. 20, Chentian Village East, Baomin 2nd  
Road, Xixiang Street, Bao'an District,  
Shenzhen, Guangdong 518100, China.

(540) Trademark Application



(511) 12

(210) No. 54251

(220) 17/04/2026

(732) Shenzhen COLS Motorcycle Trade Co., Ltd.  
No. 20, Chentian Village East, Baomin 2nd  
Road, Xixiang Street, Bao'an District,  
Shenzhen, Guangdong 518100, China.

(540) Trademark Application



(511) 03

(210) No. 54252

(220) 17/04/2026

(732) Wu Chuncheng

House 101, No. 5, Shizhi Lane 14, Xiacuo

Houshujiao, Heping Town, Chaoyang

District, Shantou City, Guangdong Province,

China.

(540) Trademark Application

**宗师傅**  
Master Zong

(511) 29, 30 and 32

(210) No. 54253

(220) 17/04/2026

(732) Zong Master Holdings (Shenzhen) Co., Ltd.

The second floor of the cafeteria of Jingshan

Experimental School, Ren Tian Community,

Fuhai Sub-district, Bao 'an District, Shenzhen

City, China.

(540) Trademark Application

**KVEX**

(511) 09

(210) No. 54254

(220) 17/04/2026

(732) Kewejie (Shenzhen) Innovation Technology  
Co., Ltd.

Room 701, Leshun Building, No. 31 Bulong  
Road, Wenjing Community, Buji Subdistrict,  
Longgang District, Shenzhen, China.

(540) Trademark Application

**Favoni**

(511) 12

(210) No. 54255

(220) 17/04/2026

(732) YAMAHA HATSUDOKI KABUSHIKI  
KAISHA

2500 Shingai, Iwata-shi, Shizuoka, Japan.

(540) Trademark Application

**Favonix**

(511) 12

(210) No. 54256

(220) 17/04/2026

(732) YAMAHA HATSUDOKI KABUSHIKI

KAISHA

2500 Shingai, Iwata-shi, Shizuoka, Japan.

(540) Trademark Application

The logo for SeaHunter features three stylized, overlapping wave-like shapes above the brand name "SeaHunter" in a bold, sans-serif font.

(511) 28

(210) No. 54257

(220) 20/04/2026

(732) ROCKER TECHNOLOGY (SHENZHEN)

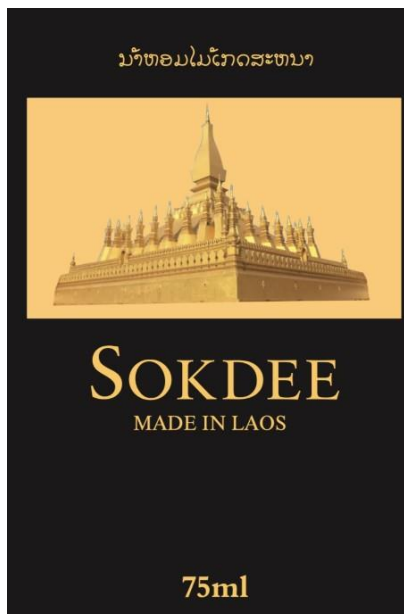
CO., LTD.

Rm 2310, Bldg 2, Boyueyuan, Dayuecheng,

Block 25, Baomin Comm, Xin'an St, Bao'an,

Shenzhen, Guangdong, 518000, China.

(540) Trademark Application



(511) 03

(210) No. 54258

(220) 20/04/2026

(732) ບໍລິສັດ ແອວບີພີ ຈຳກັດ

ບ້ານໂຊກຄຳ, ເມືອງໄຊເສດຖາ, ນະຄອນຫຼວງວຽງຈັນ,  
ສປປ ລາວ

(540) Trademark Application

The image shows a trademark application for the Lao word 'ທູດ' (Tud). The characters are rendered in a stylized, bold, black font with a slight shadow effect.

(511) 14

(210) No. 54259

(220) 20/04/2026

(732) MONTRES TUDOR SA

Rue François-Dussaud 3, Geneva,  
Switzerland.

(540) Trademark Application



(511) 14

(210) No. 54261

(220) 20/04/2026

(732) Huang Chengfang

Room 406, No. 762, Lianqian East Road,  
Siming District, Xiamen, Fujian, China.

(540) Trademark Application

(511) 11

(210) No. 54262

(220) 20/04/2026

(732) Huang Chengfang

Room 406, No. 762, Lianqian East Road,  
Siming District, Xiamen, Fujian, China.

(540) Trademark Application



**JOYRIDER**

(511) 09

(210) No. 54263

(220) 20/04/2026

(732) Huang Chengfang

Room 406, No. 762, Lianqian East Road,  
Siming District, Xiamen, Fujian, China.

(540) Trademark Application



**XTTX**

(511) 07

(210) No. 54264

(220) 20/04/2026

(732) Huang Chengfang

Room 406, No. 762, Lianqian East Road,  
Siming District, Xiamen, Fujian, China.

(540) Trademark Application



(511) 11, 21 and 37

(210) No. 54265

(220) 21/04/2026

(732) FUYUAN CAPITAL PTE. LTD.

16 CHESTNUT CLOSE, GREEN HILL  
ESTATE, 679456, SINGAPORE.

(540) Trademark Application

**阿正茶夫**  
A Z H E N G C H A F U

(511) 43

(210) No. 54266

(220) 21/04/2026

(732) Zhang Peng

No. 48, Dawangzhuang Village, Sunzhuang  
Township, Wuqiang County, Hengshui City,  
Hebei Province, China.

(540) Trademark Application



(511) 35

(210) No. 54267

(220) 21/04/2026

(732) FamilyMart Co., Ltd.

3-1-21 Shibaura, Minato-ku, Tokyo, Japan.

(540) Trademark Application

**FAMILYMART**

(511) 35

(210) No. 54268

(220) 21/04/2026

(732) FamilyMart Co., Ltd.

3-1-21 Shibaura, Minato-ku, Tokyo, Japan.

(540) Trademark Application



(511) 35

(210) No. 54270

(220) 22/04/2026

(732) ບໍລິສັດ ກັນຍາພັດ ໂກຣໂບໂທຣດ ຈຳກັດຜູ້ດຽວ.

ບ້ານ ໜອງວຽງຄຳ, ເມືອງ ໄຊທານີ,

ນະຄອນຫຼວງວຽງຈັນ, ສປປ ລາວ

(540) Trademark Application



(511) 12

(210) No. 54271

(220) 22/04/2026

(732) ZHEJIANG CFMOTO POWER CO., LTD.

No.116, Wuzhou Road, Yuhang Economic

Development Zone, Hangzhou, Zhejiang

Province, China.

(540) Trademark Application

The logo consists of the letters 'ZEHO' in a bold, black, sans-serif font. A white diagonal slash is positioned between the 'E' and 'H'.

(511) 12

(210) No. 54272

(220) 22/04/2026

(732) ZHEJIANG CFMOTO POWER CO., LTD.

No.116, Wuzhou Road, Yuhang Economic  
Development Zone, Hangzhou, Zhejiang  
Province, China.

(540) Trademark Application

The logo consists of the letters 'ZEHO' in a bold, black, sans-serif font. A white diagonal slash is positioned between the 'E' and 'H'.

(511) 12

(210) No. 54273

(220) 22/04/2026

(732) ZHEJIANG CFMOTO POWER CO., LTD.

No.116, Wuzhou Road, Yuhang Economic  
Development Zone, Hangzhou, Zhejiang  
Province, China.

(540) Trademark Application



(511) 30

(210) No. 54276

(220) 22/04/2026

(732) BARILLA G. E R. FRATELLI - SOCIETA  
PER AZIONI

Via Mantova 166, Parma, Italy.

(540) Trademark Application

**UNDERNESS**

(511) 25

(210) No. 54277

(220) 22/04/2026

(732) AN PHAT APH COMPANY LIMITED

No. 82, Dan Hoi Street, O Dien commune,  
Hanoi, Vietnam.

(540) Trademark Application

**BOOTS**

(511) 34

(210) No. 54278

(220) 22/04/2026

(732) MINH TAM DEVELOPMENT SOLE  
CO.,LTD

National Highway 8, Phonpheng Village,  
Khamkeuth District, Bolikhamxay Province.

(540) Trademark Application

**柏翠丝**

(511) 03

(210) No. 54279

(220) 22/04/2026

(732) Dameiren (Shenzhen) Industrial Group Co.,  
Ltd.

Room 30A, Building 1, Qiaocheng Fang, No.  
4080 Qiaoxiang Road, Gaofa Community,  
Shahe Street, Nanshan District, Shenzhen,  
Guangdong Province, China.

(540) Trademark Application

PROINSCARE

(511) 03

(210) No. 54280

(220) 22/04/2026

(732) Guangzhou LocRoyal Cosmetics Co., Ltd.

Room 305, Building 2, Huihe Tiandi, No. 26,  
Second Road, Wanggang Industrial Zone,  
Jiahe Street, Baiyun District, Guangzhou  
City, Guangdong Province, China.

(540) Trademark Application



(511) 32

(210) No. 54281

(220) 23/04/2026

(732) ໂຮງງານ ວາດສະໜາ ເຫຼົ້າ ແລະ ເຄື່ອງດື່ມ

ບ້ານ ຍາພະ, ເມືອງ ສີໂຄດຕະບອງ,

ນະຄອນຫຼວງວຽງຈັນ, ສປປ ລາວ

(540) Trademark Application



(511) 30 and 35

(210) No. 54282

(220) 23/04/2026

(732) ບໍລິສັດ ຄາສະວາ ດຣາກອນ ຈຳກັດຜູ້ດຽວ  
ບ້ານ ນາຊວງ, ເມືອງ ວຽງທອງ, ແຂວງ ບໍລິຄຳໄຊ,  
ສປປ ລາວ.

(540) Trademark Application



(511) 30

(210) No. 54283

(220) 23/04/2026

(732) ບໍລິສັດ ຄາສະວາ ດຣາກອນ ຈຳກັດຜູ້ດຽວ  
ບ້ານ ນາຊວງ, ເມືອງ ວຽງທອງ, ແຂວງ ບໍລິຄຳໄຊ,  
ສປປ ລາວ.

(540) Trademark Application



(511) 30

(210) No. 54284

(220) 23/04/2026

(732) ບໍລິສັດ ຄາສະວາ ດຣາກອນ ຈຳກັດຜູ້ດຽວ  
ບ້ານ ນາຊວງ, ເມືອງ ວຽງທອງ, ແຂວງ ບໍລິຄຳໄຊ,  
ສປປ ລາວ.

(540) Trademark Application



(511) 30

(210) No. 54285

(220) 23/04/2026

(732) ບໍລິສັດ ລົງທຶນສາກົນລາວ-ຫວຽດ ຈຳກັດຜູ້ດຽວ  
ບ້ານ ສິບພວນ, ເມືອງ ຄຳເກີດ, ແຂວງ ບໍລິຄຳໄຊ,  
ສປປ ລາວ.

(540) Trademark Application



(511) 30

(210) No. 54286

(220) 23/04/2026

(732) ບໍລິສັດ ລົງທຶນສາກົນລາວ-ຫວຽດ ຈຳກັດຜູ້ດຽວ  
ບ້ານ ສີບພວນ, ເມືອງ ຄຳເກີດ, ແຂວງ ບໍລິຄຳໄຊ,  
ສປປ ລາວ.

(540) Trademark Application



(511) 30 and 35

(210) No. 54287

(220) 23/04/2026

(732) ບໍລິສັດ ລົງທຶນສາກົນລາວ-ຫວຽດ ຈຳກັດຜູ້ດຽວ  
ບ້ານ ສີບພວນ, ເມືອງ ຄຳເກີດ, ແຂວງ ບໍລິຄຳໄຊ,  
ສປປ ລາວ.

(540) Trademark Application



(511) 06, 37, 40, 41 and 42

(210) No. 54290

(220) 24/04/2026

(732) ບໍລິສັດ ລ້ານຊ້າງ ມິເນໂຣນສ໌ ຈຳກັດ

ຖະໜົນບຸຣິຈັນ, ບ້ານ ໂພນສິນວນ, ເມືອງ ສີສັດຕະນາກ

ຕູ້ ປ.ນ. 4486, ນະຄອນຫຼວງວຽງຈັນ ສ ປປ ລາວ.

(540) Trademark Application



(511) 06, 37, 40, 41 and 42

(210) No. 54291

(220) 24/04/2026

(732) ບໍລິສັດ ລ້ານຊ້າງ ມິເນໂຣນສ໌ ຈຳກັດ

ຖະໜົນບຸຣິຈັນ, ບ້ານ ໂພນສິນວນ, ເມືອງ ສີສັດຕະນາກ

ຕູ້ ປ.ນ. 4486, ນະຄອນຫຼວງວຽງຈັນ ສ ປປ ລາວ.

(540) Trademark Application



(511) 06, 37, 40, 41 and 42

(210) No. 54292

(220) 24/04/2026

(732) ບໍລິສັດ ລ້ານຊ້າງ ມິເນໂຣນສ໌ ຈຳກັດ

ຖະໜົນບຸຣີຈັນ, ບ້ານ ໂພນສິນວນ, ເມືອງ ສີສັດຕະນາກ

ຕູ້ ປ.ນ. 4486, ນະຄອນຫຼວງວຽງຈັນ ສ ປປ ລາວ.

(540) Trademark Application



(511) 25 and 41

(210) No. 54293

(220) 24/04/2026

(732) KLAO Fashion co., ltd

Phonethan Village, Saysettha, District,

Vientiane Capital.

(540) Trademark Application

**J.M.C.Y**

(511) 03

(210) No. 54294

(220) 24/04/2026

(732) Hu, Ximing

No. 33, Qingquan Road, Hourenhu Village,  
Lanjiang Street, Lanxi City, Zhejiang  
Province, China.

(540) Trademark Application

**Touchmark**

(511) 16

(210) No. 54295

(220) 24/04/2026

(732) Shanghai Zhende Culture Technology Co.,  
Ltd.

Building 4, No. 878 Jianchuan Road, Minhang  
District, Shanghai city, China.

(540) Trademark Application



(511) 12

(210) No. 54296

(220) 25/04/2026

(732) Jiangsu Jimai New Energy Vehicle Industry  
Co., Ltd.

South of Xiwei 1st Road, Xuzhou Industrial  
Park, Jiangsu, China.

(540) Trademark Application



(511) 32

(210) No. 54297

(220) 27/04/2026

(732) MINTANA COMPANY LIMITED

50/1 Chaloeprakiat Rama 9 Soi 9, Yak 2,  
Nongbon, Praves, Bangkok 10250, Thailand.

(540) Trademark Application



YI HOTEL

颐华酒店

(511) 35, 36 and 43

(210) No. 54298

(220) 27/04/2026

(732) Wanda Hotel Management (Shanghai) Co.,  
Ltd.

Room 210, West Zone, 2nd Floor, No. 707  
Zhangyang Road, Shanghai Pilot Free Trade  
Zone, China.

(540) Trademark Application



(511) 35, 36 and 45

(210) No. 54299

(220) 27/04/2026

(732) KASIKORNBANK PUBLIC COMPANY  
LIMITED

400/22 Phahon Yothin Road, Sam Sen Nai  
Sub-District, Phaya Thai District, Bangkok,  
10400, Thailand.

(540) Trademark Application



(511) 35, 36 and 45

(210) No. 54300

(220) 27/04/2026

(732) KASIKORNBANK PUBLIC COMPANY  
LIMITED

400/22 Phahon Yothin Road, Sam Sen Nai  
Sub-District, Phaya Thai District, Bangkok,  
10400, Thailand.

(540) Trademark Application



(511) 31

(210) No. 54301

(220) 28/04/2026

(732) ບໍລິສັດ ຢາງຊີລາວ ຫົວອາຫານສັດ ຈຳກັດ.

ບ້ານ ພັດທະນາ, ເມືອງ ນາຊາຍທອງ,

ນະຄອນຫຼວງວຽງຈັນ, ສປປ ລາວ

(540) Trademark Application



(511) 29

(210) No. 54302

(220) 28/04/2026

(732) Shenzhen Nong Geng Ji Catering Co., Ltd.

East side, 1st Floor, Guangdong Frontier  
Defense Building, 5 Fujing Road, Futian  
Street, Futian District, Shenzhen, China.

(540) Trademark Application



(511) 35

(210) No. 54303

(220) 28/04/2026

(732) Shenzhen Nong Geng Ji Catering Co., Ltd.

East side, 1st Floor, Guangdong Frontier  
Defense Building, 5 Fujing Road, Futian  
Street, Futian District, Shenzhen, China.

(540) Trademark Application



(511) 43

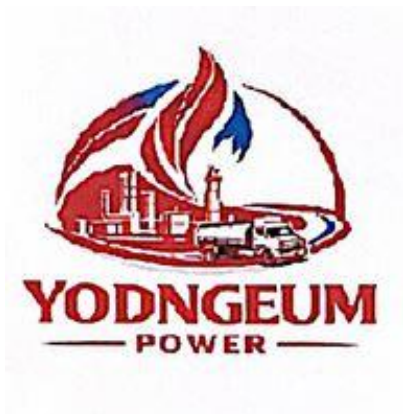
(210) No. 54304

(220) 28/04/2026

(732) Shenzhen Nong Geng Ji Catering Co., Ltd.

East side, 1st Floor, Guangdong Frontier  
Defense Building, 5 Fujing Road, Futian  
Street, Futian District, Shenzhen, China.

(540) Trademark Application



(511) 04, 35, 37 and 40

(210) No. 54305

(220) 28/04/2026

(732) ບໍລິສັດ ຍອດຊື່ມ ພາວເວີ ຈຳກັດ

ບ້ານ ຍອດຊື່ມ, ເມືອງ ແປກ, ແຂວງ ຊຽງຂວາງ,  
ສປປ ລາວ.

(540) Trademark Application



(511) 32

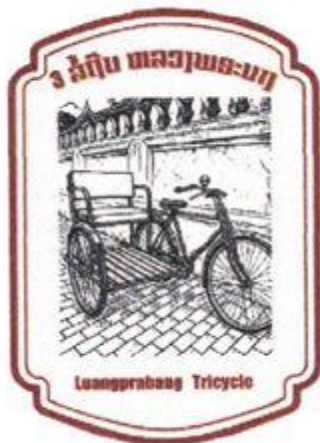
(210) No. 54306

(220) 28/04/2026

(732) ບໍລິສັດ ຈິງເສີນ ຂາເຂົ້າ-ຂາອອກ ຈຳກັດ

ບ້ານ ເທິນ ເມືອງແປກ ແຂວງ ຊຽງຂວາງ, ສປປ ລາວ

(540) Trademark Application



(511) 39

(210) No. 54308

(220) 28/04/2026

(732) ວິສາຫະກິດສ່ວນບຸກຄົນ ສາມລໍ່ຖິບ ຫຼວງພະບາງ

ບ້ານ ວັດແສນ, ນະຄອນຫຼວງພະບາງ,

ແຂວງ ຫຼວງພະບາງ, ສປປ ລາວ.

(540) Trademark Application



(511) 29 and 43

(210) No. 54309

(220) 28/04/2026

(732) ທ່ານ ວິໄລສັກ ຊະມຸນຕິ

ບ້ານ ສີດໍາດວນ, ເມືອງ ຈັນທະບູລີ,

ນະຄອນຫຼວງວຽງຈັນ, ສປປ ລາວ

(540) Trademark Application



(511) 30 and 43

(210) No. 54310

(220) 28/04/2026

(732) ທ່ານ ນາງ ວຽງສະຫວັນ ດວງມະນີ

ບ້ານ ສີດໍາດວນ, ເມືອງ ຈັນທະບູລີ,

ນະຄອນຫຼວງວຽງຈັນ, ສປປ ລາວ

(540) Trademark Application



(511) 30

(210) No. 54311

(220) 28/04/2026

(732) ບໍລິສັດ ກາເຟ ພູເບີ້ຍ ຈຳກັດຜູ້ດຽວ  
ບ້ານ ໂຊກໃຫຍ່, ເມືອງ ໄຊເສດຖາ,  
ນະຄອນຫຼວງວຽງຈັນ, ສປປ ລາວ

(540) Trademark Application



(511) 30

(210) No. 54312

(220) 28/04/2026

(732) ບໍລິສັດ ກາເຟ ພູເບີ້ຍ ຈຳກັດຜູ້ດຽວ  
ບ້ານ ໂຊກໃຫຍ່, ເມືອງ ໄຊເສດຖາ,  
ນະຄອນຫຼວງວຽງຈັນ, ສປປ ລາວ

(540) Trademark Application



(511) 30

(210) No. 54313

(220) 28/04/2026

(732) ບໍລິສັດ ກາເຟ ພູເບ້ຍ ຈຳກັດຜູ້ດຽວ  
ບ້ານ ໂຊກໃຫຍ່, ເມືອງ ໄຊເສດຖາ,  
ນະຄອນຫຼວງວຽງຈັນ, ສປປ ລາວ

(540) Trademark Application



(511) 32

(210) No. 54314

(220) 28/04/2026

(732) ບໍລິສັດ ກາເຟ ພູເບ້ຍ ຈຳກັດຜູ້ດຽວ  
ບ້ານ ໂຊກໃຫຍ່, ເມືອງ ໄຊເສດຖາ,  
ນະຄອນຫຼວງວຽງຈັນ, ສປປ ລາວ

(540) Trademark Application

シルキーベール

(511) 03

(210) No. 54315

(220) 29/04/2026

(732) UNI-CHARM CORPORATION

182 Shimobun, Kinsei-cho, Shikokuchuo-shi,  
Ehime-ken, Japan.

(540) Trademark Application

Cha π

(511) 30

(210) No. 54316

(220) 29/04/2026

(732) NONGFU SPRING CO., LTD.

No. 181, Geyazhuang, Xihu District,  
Hangzhou, Zhejiang, China.

(540) Trademark Application



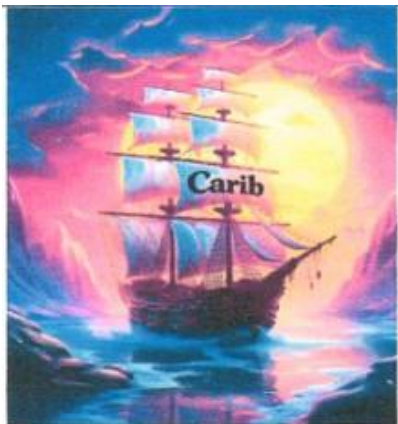
(511) 32 and 43

(210) No. 54317

(220) 29/04/2026

(732) Warsteiner Brauerei Haus Cramer KG  
Domring 4-10, 59581 Warstein, Germany.

(540) Trademark Application



(511) 34

(210) No. 54318

(220) 29/04/2026

(732) ບໍລິສັດ ກົວຟຸໝິນຊຽງ ຂາເຂົ້າ-ຂາອອກ ຈຳກັດຜູ້ດຽວ  
ບ້ານ ໜອງດ້ວງທົ່ງ, ເມືອງ ສີໂຄດຕະບອງ,  
ນະຄອນຫຼວງວຽງຈັນ, ສປປ ລາວ

(540) Trademark Application



(511) 34

(210) No. 54319

(220) 29/04/2026

(732) ບໍລິສັດ ກົວຟຸໜິນຊຽງ ຂາເຂົ້າ-ຂາອອກ ຈຳກັດຜູ້ດຽວ  
ບ້ານ ໜອງດ້ວງທົ່ງ, ເມືອງ ສີໂຄດຕະບອງ,  
ນະຄອນຫຼວງວຽງຈັນ, ສປປ ລາວ

(540) Trademark Application

加勒比海盜  
JIA LE BI HAI DAO

(511) 34

(210) No. 54320

(220) 29/04/2026

(732) ບໍລິສັດ ກົວຟຸໜິນຊຽງ ຂາເຂົ້າ-ຂາອອກ ຈຳກັດຜູ້ດຽວ  
ບ້ານ ໜອງດ້ວງທົ່ງ, ເມືອງ ສີໂຄດຕະບອງ,  
ນະຄອນຫຼວງວຽງຈັນ, ສປປ ລາວ

(540) Trademark Application



(511) 12

(210) No. 54321

(220) 29/04/2026

(732) ບໍລິສັດ ເຄອິສະຕາ ນໍາເຂົ້າ ແລະ ສົ່ງອອກ ຈໍາກັດຜູ້ດຽວ.  
ບ້ານ ທາດຫລວງໃຕ້, ເມືອງ ໄຊເສດຖາ,  
ນະຄອນຫຼວງວຽງຈັນ, ສປປ ລາວ

(540) Trademark Application



(511) 12

(210) No. 54322

(220) 29/04/2026

(732) ບໍລິສັດ ເຄອິສະຕາ ນໍາເຂົ້າ ແລະ ສົ່ງອອກ ຈໍາກັດຜູ້ດຽວ.  
ບ້ານ ທາດຫລວງໃຕ້, ເມືອງ ໄຊເສດຖາ,  
ນະຄອນຫຼວງວຽງຈັນ, ສປປ ລາວ

(540) Trademark Application

ELEMENT BY MARRIOTT

(511) 35 and 43

(210) No. 54324

(220) 30/04/2026

(732) Marriott Worldwide Corporation

7750 Wisconsin Avenue, Bethesda,

Maryland 20814, United States of America.

(540) Trademark Application



(511) 35 and 43

(210) No. 54325

(220) 30/04/2026

(732) Marriott Worldwide Corporation

7750 Wisconsin Avenue, Bethesda,

Maryland 20814, United States of America.

(540) Trademark Application



(511) 32

(210) No. 54326

(220) 30/04/2026

(732) ບໍລິສັດ ຫິງເມັ້ນ ຝັດທະນາການລົງທຶນການກະສິກໍາ  
ຈໍາກັດຜູ້ດຽວ  
ບ້ານ ສີໂຄທົ່ງ, ເມືອງ ສີໂຄດຕະບອງ,  
ນະຄອນຫຼວງວຽງຈັນ, ສປປ ລາວ

(540) Trademark Application



(511) 11

(210) No. 54327

(220) 30/04/2026

(732) GUANGDONG SUN YOUNG LIGHTING  
CO., LTD.  
No. 218, Xiaochong North Babao Road,  
Yangmei Village, Sanjiang Town, Xinhui  
District, Jiangmen City 529100, China.

## ພາກທີ III

### (Part III)

## ເຄື່ອງໝາຍການຄ້າ

### Trademarks

#### 2. ຜົນການຈົດທະບຽນ

#### (Registration)

##### ຄຳອະທິບາຍກ່ຽວກັບລະຫັດຫຍໍ້

##### (Introduction of Codes)

- (540) ເຄື່ອງໝາຍການຄ້າ (Trademark)
- (511) ໝວດ (Nice Classification)
- (210) ເລກທີ ຄຳຮ້ອງ (Number of the application)
- (220) ວັນທີ ຄຳຮ້ອງ (Date of filing of the application)
- (732) ຊື່ ແລະ ທີ່ຢູ່ ຂອງຜູ້ຍື່ນຄຳຮ້ອງ (Name and Address of applicant)
- (111) ເລກທີ ການຈົດທະບຽນເຄື່ອງໝາຍການຄ້າ (Number of the registration)
- (180) ວັນໝົດອາຍຸຂອງການຈົດທະບຽນ (Expiration date of the registration)

**ພາກທີ III**  
**(Part III)**  
**ເຄື່ອງໝາຍການຄ້າ**  
**Trademarks**

**3. ການຕໍ່ອາຍຸ**  
**(Renewal)**

**ຄຳອະທິບາຍກ່ຽວກັບລະຫັດຫຍໍ້**  
**(Introduction of Codes)**

- (540) ເຄື່ອງໝາຍການຄ້າ (Trademark)
- (511) ໝວດ (Nice Classification)
- (210) ເລກທີ ຄຳຮ້ອງ (Number of the application)
- (220) ວັນທີ ຄຳຮ້ອງ (Date of filing of the application)
- (732) ຊື່ ແລະ ທີ່ຢູ່ ຂອງຜູ້ຍື່ນຄຳຮ້ອງ (Name and Address of applicant)
- (111) ເລກທີການຈັດທະບຽນເຄື່ອງໝາຍການຄ້າ (Number of the registration)
- (180) ການຕໍ່ອາຍຸການຈັດທະບຽນ (Expiration date of the renewal)

**ພາກທີ III**  
**(Part III)**

**ເຄື່ອງໝາຍການຄ້າ**  
**Trademarks**

**4. ການປ່ຽນແປງ**  
**(Changes)**

**ພາກທີ III**  
**(Part III)**  
**ເຄື່ອງໝາຍການຄ້າ**  
**Trademarks**

**5. ການດັດແກ້**  
**(Amendments)**

## ພາກທີ IV

### (Part IV)

## ເຄື່ອງໝາຍການຄ້າຜ່ານລະບົບມາດຣິດ

## Trademarks via Madrid Protocol

### 1. ຄໍາຮ້ອງ

#### (Applications)

#### ຄໍາອະທິບາຍກ່ຽວກັບລະຫັດຫຍໍ້

#### (Introduction of Codes)

- (540) ເຄື່ອງໝາຍການຄ້າ (Trademark)
- (511) ໝວດ (Nice Classification)
- (210) ເລກທີ ຄໍາຮ້ອງ (Number of the application)
- (220) ວັນທີ ຄໍາຮ້ອງ (Date of filing of the application)
- (732) ຊື່ ແລະ ທີ່ຢູ່ ຂອງຜູ້ຍື່ນຄໍາຮ້ອງ (Name and Address of applicant)

## ພາກທີ IV

### (Part IV)

## ເຄື່ອງໝາຍການຄ້າຜ່ານລະບົບມາດຣິດ

## Trademarks via Madrid Protocol

### 2. ຜົນການຈົດທະບຽນ

#### (Registration)

##### ຄຳອະທິບາຍກ່ຽວກັບລະຫັດຫຍໍ້

##### (Introduction of Codes)

- (540) ເຄື່ອງໝາຍການຄ້າ (Trademark)
- (511) ໝວດ (Nice Classification)
- (210) ເລກທີ ຄຳຮ້ອງ (Number of the application)
- (220) ວັນທີ ຍື່ນຄຳຮ້ອງ (Date of filing of the application)
- (732) ຊື່ ແລະ ທີ່ຢູ່ ຂອງຜູ້ຍື່ນຄຳຮ້ອງ (Name and Address of applicant)
- (111) ເລກທີການຈົດທະບຽນເຄື່ອງໝາຍການຄ້າ (Number of the registration)
- (180) ວັນໝົດອາຍຸຂອງການຈົດທະບຽນ (Expiration date of the registration)

**ພາກທີ IV**  
**(Part IV)**

**ເຄື່ອງໝາຍການຄ້າຜ່ານລະບົບມາດຣິດ**  
**Trademarks via Madrid Protocol**

**3. ຜົນການຕໍ່ອາຍຸ**  
**(Renewal)**

**ຄຳອະທິບາຍກ່ຽວກັບລະຫັດຫຍໍ້**  
**(Introduction of Codes)**

- (540) ເຄື່ອງໝາຍການຄ້າ (Trademark)
- (511) ໝວດ (Nice Classification)
- (210) ເລກທີ ຄຳຮ້ອງ (Number of the application)
- (220) ວັນທີ ຍື່ນຄຳຮ້ອງ (Date of filing of the application)
- (732) ຊື່ ແລະ ທີ່ຢູ່ ຂອງຜູ້ຍື່ນຄຳຮ້ອງ (Name and Address of applicant)
- (111) ເລກທີການຈົດທະບຽນເຄື່ອງໝາຍການຄ້າ (Number of the registration)
- (180) ການຕໍ່ອາຍຸຂອງການຈົດທະບຽນ (Expiration date of the renewal)

**ພາກທີ IV**

**(Part IV)**

**ເຄື່ອງໝາຍການຄ້າຜ່ານລະບົບມາດຣິດ**

**Trademarks via Madrid Protocol**

**4. ການປ່ຽນແປງ**

**(Changes)**

**ພາກທີ IV**

**(Part IV)**

**ເຄື່ອງໝາຍການຄ້າຜ່ານລະບົບມາດຣິດ**

**Trademarks via Madrid Protocol**

**5. ການດັດແກ້**

**(Amendments)**

**ພາກທີ V**  
**(Part V)**  
**ຖິ່ນກຳເນີດ**  
**Geographical Indications**

**1. ຄຳຮ້ອງ**  
**(Applications)**

**ພາກທີ V**  
**(Part V)**  
**ຖິ່ນກຳເນີດ**  
**Geographical Indications**

**2. ຜົນການຈົດທະບຽນ**  
**(Registration)**

**ພາກທີ V**  
**(Part V)**  
**ຖິ່ນກຳເນີດ**  
**Geographical Indications**

**2.1 ຜົນການຈົດທະບຽນ ຜ່ານລະບົບສາກົນ**  
**(Lisbon Registration)**

**ພາກທີ V**  
**(Part V)**  
**ຖິ່ນກຳເນີດ**  
**Geographical Indications**

**2.2 ຜົນການຈົດທະບຽນ ຊື່ຖິ່ນກຳເນີດສະເພາະ ຜ່ານລະບົບສາກົນ**  
**(Lisbon Appellation of Origin Registration)**

**ພາກທີ V**

**(Part V)**

**ຖິ່ນກຳເນີດ**

**Geographical Indications**

**3. ການປ່ຽນແປງ**

**(Changes)**

**ພາກທີ V**  
**(Part V)**  
**ຖິ່ນກຳເນີດ**  
**Geographical Indications**

**4. ການດັດແກ້**  
**(Amendments)**

**ພາກທີ VI**

**(Part VI)**

**ພັນພືດໃໝ່**

**New Plant Varieties**

**1. ຄໍາຮ້ອງ**

**(Applications)**

**ພາກທີ VI**

**(Part VI)**

**ພັນພືດໃໝ່**

**New Plant Varieties**

**2. ຜົນການຈັດທະບຽນ**

**(Registration)**

**ພາກທີ VI**  
**(Part VI)**

**ພັນພືດໃໝ່**  
**New Plant Varieties**

**3. ການປ່ຽນແປງ**  
**(Changes)**

**ພາກທີ VI**

**(Part VI)**

**ພັນພືດໃໝ່**

**New Plant Varieties**

**4. ການດັດແກ້**

**(Amendments)**

**ພາກທີ VII**

**(Part VII)**

**ລິຂະສິດ ແລະ ສິດກ່ຽວຂ້ອງກັບລິຂະສິດ**

**Copyrights and Related Rights**

**1. ການແຈ້ງຂໍ້ມູນ**

**(Notifications)**

**ພາກທີ VII**

**(Part VII)**

**ລິຂະສິດ ແລະ ສິດກ່ຽວຂ້ອງກັບລິຂະສິດ**

**Copyrights and Related Rights**

**2. ການປ່ຽນແປງ**

**(Changes)**

**ພາກທີ VIII**

**(Part VIII)**

**ການແກ້ໄຂຂໍ້ຂັດແຍ່ງທາງດ້ານບໍລິຫານກ່ຽວກັບການຈົດທະບຽນຊັບ  
ສິນອຸດສາຫະກຳ ແລະ ພັນພືດໃໝ່**

**Administrative Dispute Resolutions on the Registration of  
Industrial Property and New Plant Varieties**

**1. ຜົນການຄັດຄ້ານຄຳຮ້ອງ**

**(Result of Oppositions)**

**ພາກທີ VIII**

**(Part VIII)**

**ການແກ້ໄຂຂໍ້ຂັດແຍ່ງທາງດ້ານບໍລິຫານກ່ຽວກັບການຈົດທະບຽນຊັບ  
ສິນອຸດສາຫະກຳ ແລະ ພັນພືດໃໝ່**

**Administrative Dispute Resolutions on the Registration of  
Industrial Property and New Plant Varieties**

**2. ຜົນການແຈ້ງປະຕິເສດ**

**(Result of Refusals)**

**ພາກທີ VIII**

**(Part VIII)**

**ການແກ້ໄຂຂໍ້ຂັດແຍ່ງທາງດ້ານບໍລິຫານກ່ຽວກັບການຈົດທະບຽນຊັບ**

**ສິນອຸດສາຫະກຳ ແລະ ພັນພືດໃໝ່**

**Administrative Dispute Resolutions on the Registration of  
Industrial Property and New Plant Varieties**

**3. ຜົນການຍົກເລີກ ຫຼື ລົບລ້າງ ຂອງການຈົດທະບຽນ**

**(Result of Cancellation or Invalidation of Registration)**